

PLAGES D'UTILISATION

Flow rates of up to:	8 m ³ /h
Manometric heads of up to:	55 m CE
Max. operating pressure:	10 bar
Max. ambient temperature:	- 10° à + 70°C
Température ambiante maxi :	+ 40°C
DN of ports:	25 à 32

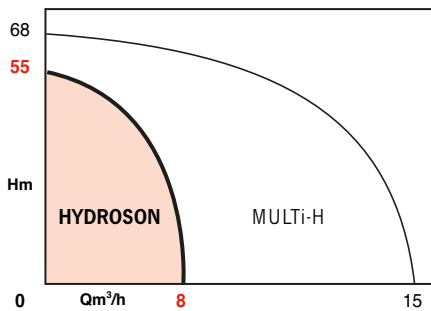

ADVANTAGES

- Corrosion-proof components.
- Quiet operation: can be used in residential premises.
- High output, reduces the number of impellers: compact and economical pump with an extended service life.
- Withstands up to 10 bar of pressure.



• Generously dimensioned motor bearings for an extended service life



• HYDROSON with three-phase motor



• HYDROSON with single-phase motor

HYDROSON

DOMESTIC MULTI-STAGE HORIZONTAL PUMPS 2-pole series - 50 Hz

APPLICATIONS

Pumping of clean and non-muddy liquids in housing and agriculture sectors.

Boosting of mains water pressure or abstraction from tanks, shallow wells, rivers and lakes for:

- Water supply and distribution
- Watering and irrigation
- Cleaning

Certified
ACS

HYDROSON

DESIGN

• Hydraulic part

- Horizontal, centrifugal, not self-priming
- Multi-stage, with 2 to 5 stages.
- Axial intake and upward vertical discharge.
- Impellers fitted directly onto the extended motor shaft.
- Shaft passage sealed by a standardised mechanical seal.
- Hydraulic assembly fastened to lantern ring at 8 points.

• Motor

- Standard ventilated
- Extended shaft end
- Single-phase motor with integrated thermal protection and automatic reset (except for version -N); capacitor fitted in the terminal box.
- IE2 three-phase motor when $P_2 \geq 0.75$ kW.
- Rotor shaft guide bearings pre-greased for their service life.

Rotation speed : 2,900 rpm
 Winding 3~ : 230-400 V
 1~ : 230 V
 Frequency : 50 Hz (option 60 Hz)
 Insulation class: 155 (F)
 Protection class: IP 54

BASIC CONSTRUCTION

Main parts	Material
Housing shell	AISI 304 stainless steel
Impellers	Noryl reinforced with 30% FG*
Stage casings	Noryl reinforced with 30% FG*
Pump shaft	AISI 431 stainless steel
Garniture mécanique	Graphite/Ceramic/Nitrile
Lantern ring mount	Aluminium
Pump-motor unit	Composite

* FG : FG: fibreglass

IDENTIFICATION

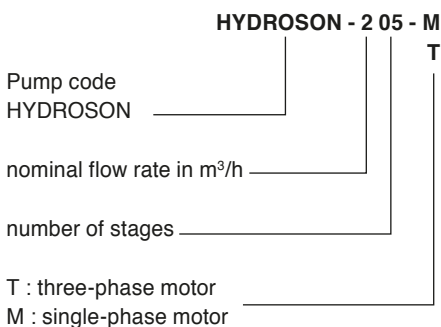

HYDRAULIC RANGE FOR PRESELECTION

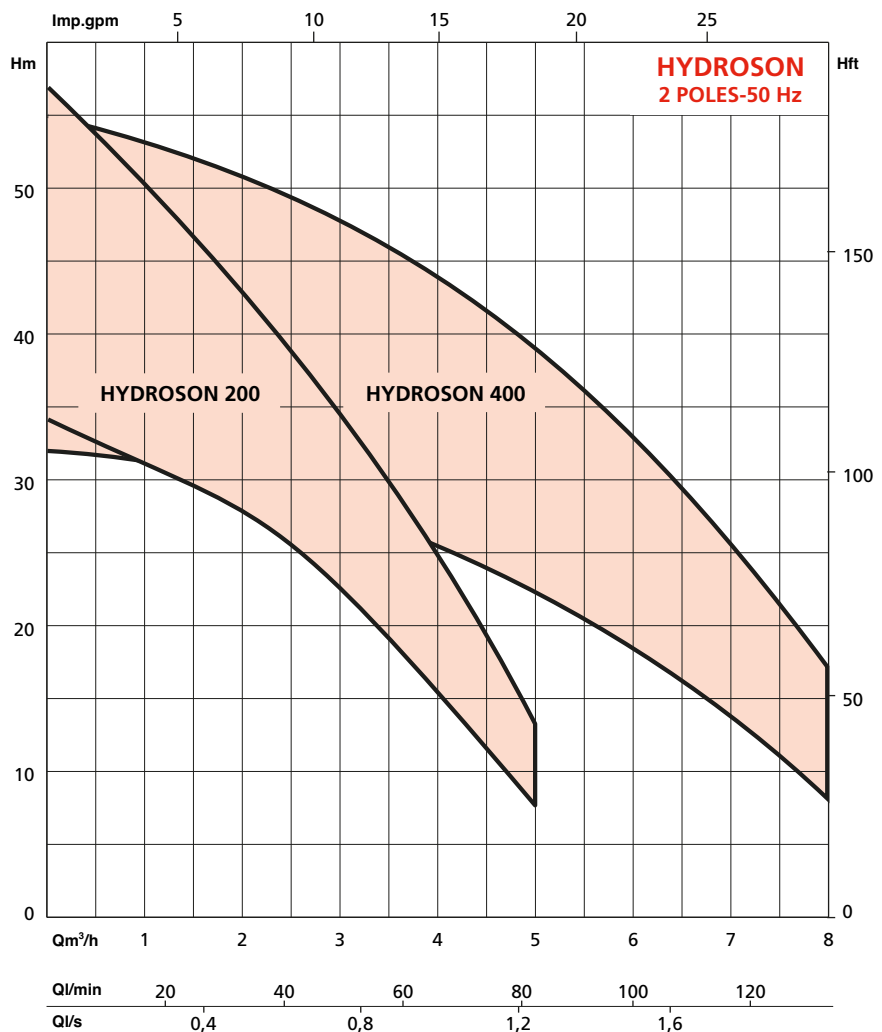

CROSS-SECTIONAL DIAGRAM

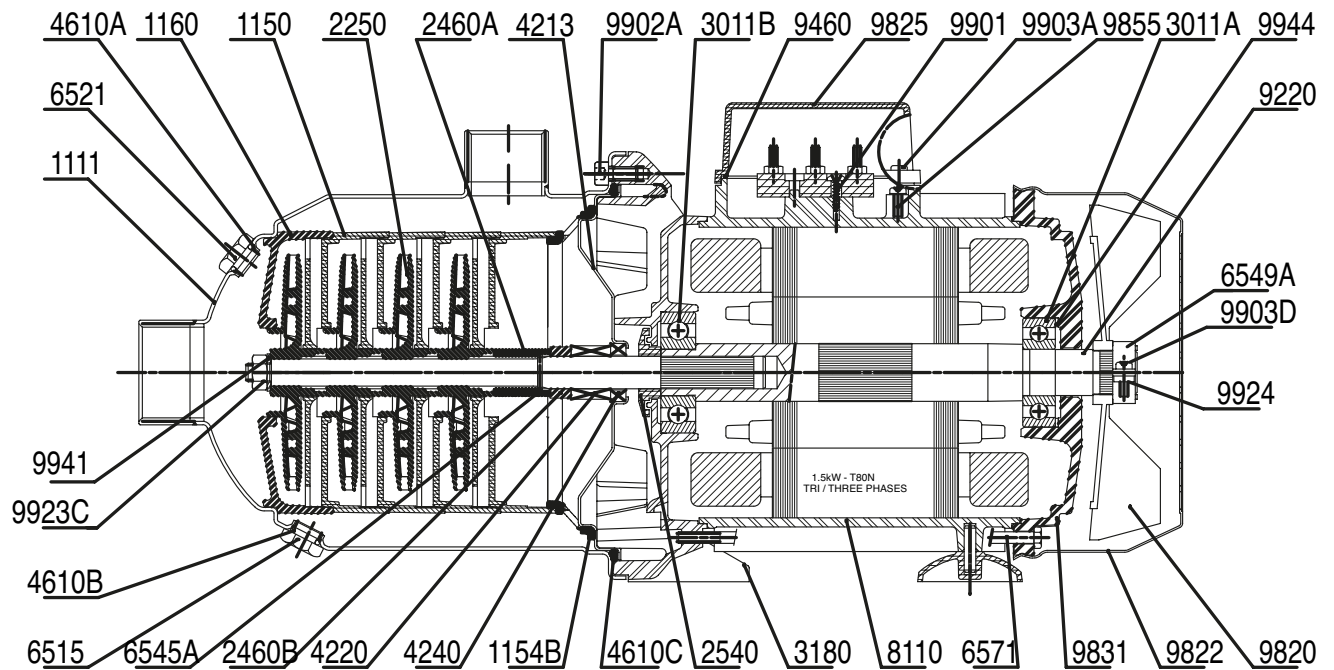

• Mechanical seal

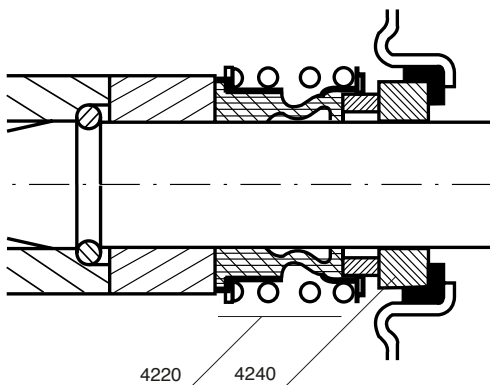

• Parts list

- | | | |
|--|---|------------------------------|
| 1111 - Housing | •4610 C - O-ring (housing-lantern ring) | 9941 - Shaft end washer |
| • 1150 - Stage casing with return channel | 6515 - Drain plug | 9944 - Spring washer |
| 1154 B - Centring device in return channel | 6521 - Bleeder and filler plug | (*) Recommended spare parts. |
| • 1160 - Stage casing without return channel | •6545 A - Circlip (support ring) | |
| • 2250 - Impeller | 6571 - Motor tie bolt | |
| 2460 A - Impeller shim | • 8110 - Electric motor casing | |
| 2460 B - Mechanical seal spacer | • 9220 - Rotor shaft | |
| 2540 - Deflector | • 9460 - Terminal block cover seal | |
| •3011 A - Fan end bearing | • 9820 - Fan | |
| •3011 B - Pump end bearing | 9822 - Fan housing | |
| 3180 - Lantern ring | • 9825 - Motor terminal block cover | |
| 4213 - Throat bushing casing | • 9830 - Front motor shroud | |
| • 4220 - Rotating part Mechanical seal | • 9831 - Rear motor bearing | |
| • 4240 - Fixed part seal | 9902 A - Housing/bearing screw | |
| •4610 A - O-ring (filler plug) | 9923 A - Housing/bearing nut | |
| •4610 B - O-ring (drain plug) | 9923 C - Shaft end nut | |

HYDROSON

HYDRAULIC PERFORMANCES

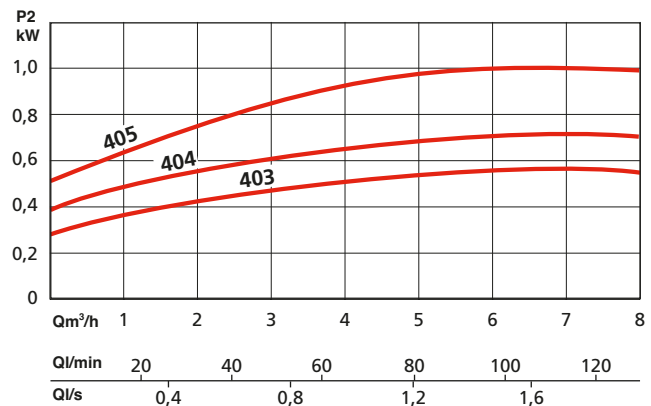
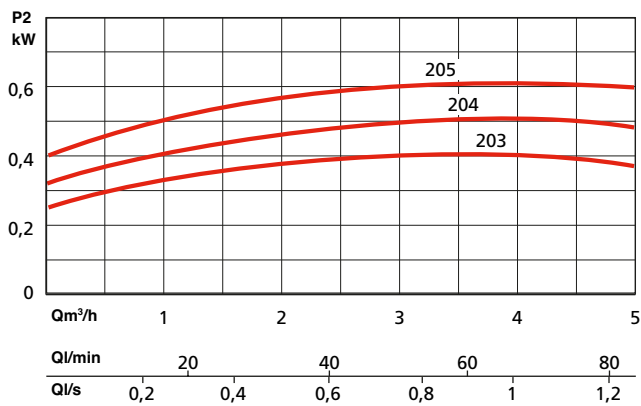
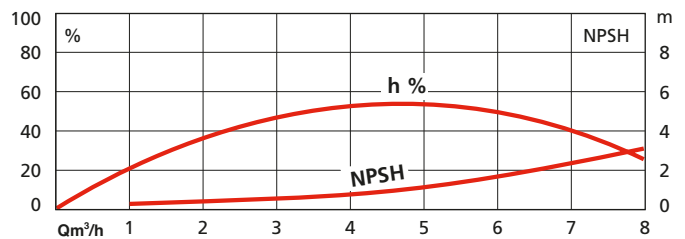
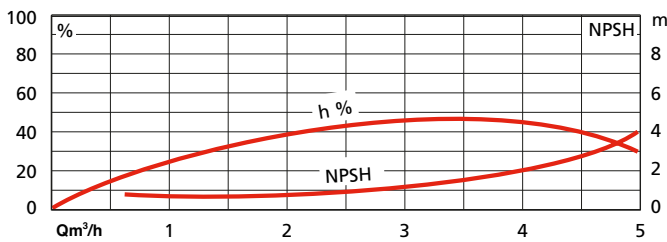
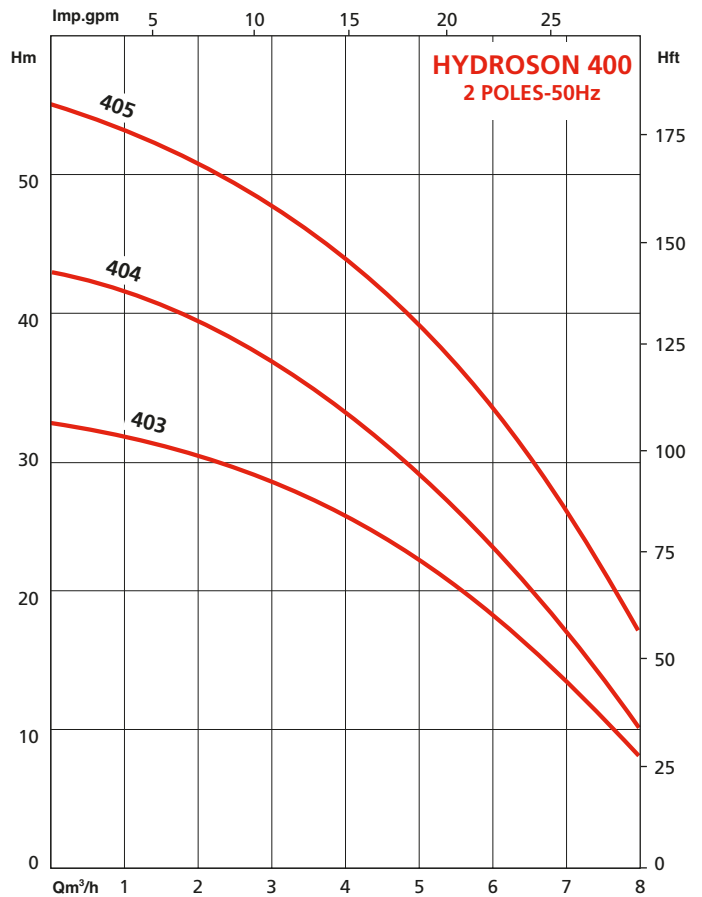
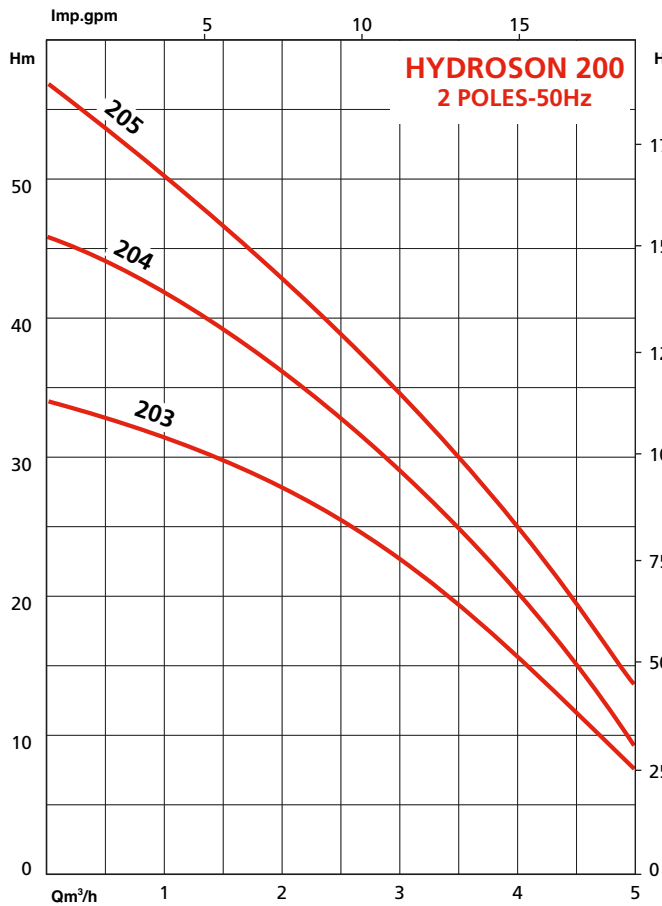

Hydraulic performance at actual speed

INSTALLATION DIAGRAMS

• Pump in suction mode

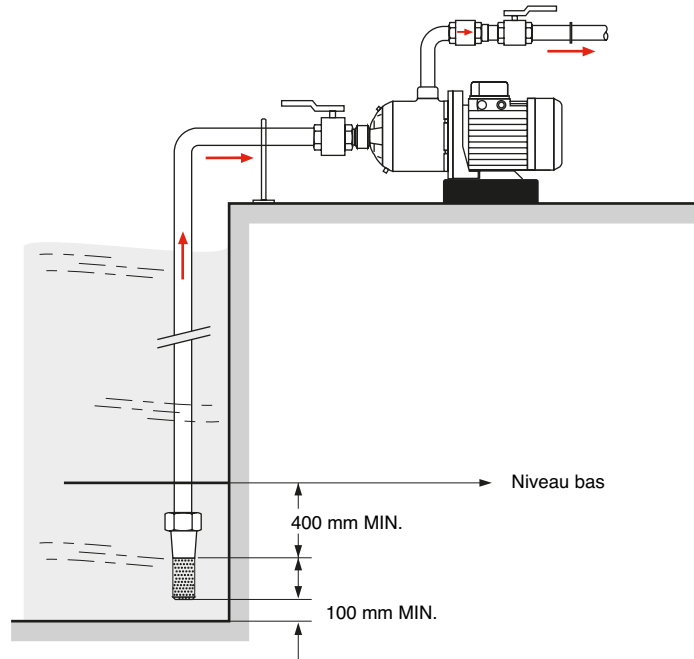

• Flooded suction pump fed by header tank or mains supply (ensure low-water protection system)

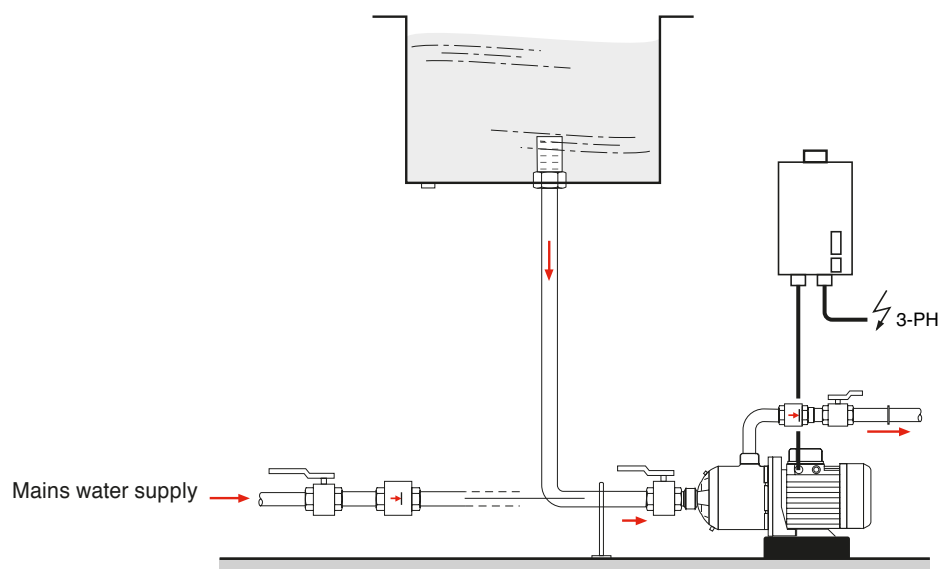

HYDROSON

ELECTRICAL AND DIMENSIONAL SPECIFICATIONS

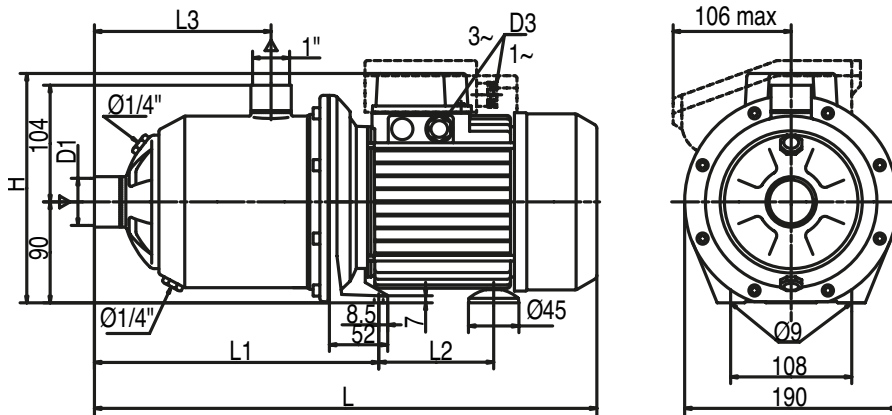

ORDER REFERENCE	MOTOR						PUMP							Weight			
	P2	Motor efficiency %			P1	In (A)			Capacitor	H	L	L1	L2		L3	D1	D3
		4/4	3/4	2/4		1X	3X	3X									
HYDROSON203-M	0,55	-	-	-	0,84	4	-	-	12	188	370	205	94	109,5	1"	PG11	8,8
HYDROSON204-M	0,55	-	-	-	0,84	4	-	-	12	188	418	253	94	157,5	1"	PG11	9,1
HYDROSON204-T	0,55	-	-	-	0,83	-	3,3	1,9	-	190	418	253	94	157,5	1"	PG11	8,2
HYDROSON205-M	0,75	-	-	-	1,09	5,1	-	-	16	216	423	253	88	157,5	1"	PG13,5	10,6
HYDROSON205N-T	0,75	77,4	77,4	76	1,11	-	3,3	1,9	-	219	457	253	110	157,5	1	1xM20	13
HYDROSON403-M	0,55	-	-	-	0,84	4	-	-	12	188	370	205	94	109,5	1 1/4"	PG11	9,4
HYDROSON403-T	0,55	-	-	-	0,83	-	3,3	1,9	-	190	370	205	94	109,5	1 1/4"	PG11	8,7
HYDROSON404-M	0,75	-	-	-	1,09	5,1	-	-	16	216	423	253	88	157,5	1 1/4"	PG13,5	10,6
HYDROSON404N-T	0,75	79,6	79,6	76	1,11	-	3,3	1,9	-	219	457	253	110	157,5	1 1/4	1xM20	13
HYDROSON405-M	1,1	-	-	-	1,51	7,2	-	-	30	224	448	253	104	157,5	1 1/4"	PG13,5	13,5
HYDROSON405N-T	1,1	79,6	79,6	78	1,57	-	4,8	2,8	-	219	457	253	110	157,5	1 1/4	1xM20	14,4

FEATURES

a) Electrical

- "T" types: 230-400 V - 50 Hz three-phase
- "M" types: 230 V - 50 Hz single-phase with capacitor installed in the terminal box.
- Three-phase motor MUST be protected by a slave switch.
- Connections to motor terminal block via cable gland.
- Provide a switch and low-water protection box in both single-phase and three-phase.

b) Installation

- Attached to mounting block with foundation bolts.
- Installation of pump in suction mode with mandatory strainer foot valve, or flooded suction pump fed by storage tank or mains supply with low water protection system.
- Connection to pump by hose or rigid piping.
- The installation must allow for the protection of the pump from adverse weather conditions and frost (no direct exposure to rain or sun).

c) Packaging

Pump delivered in a carton without connection accessories.

d) Maintenance

Remplacement des pièces de rechange recommandées (*) sujettes à usure.

OPTIONS ET ACCESSOIRES

- Vannes d'isolement
- Clapets anti-retour
- Clapet de pied-crêpine
- Manchons anti-vibratoires
- Kit d'aspiration
- Réservoirs à vessie
- Réservoirs anti-bélier
- Kit ME de protection manque d'eau
- ACSON: dispositif de commande marche-arrêt et de protection manque d'eau.
- Discontacteur de protection moteur TRI...

OPERATING RANGES

Flow rates of up to:	8 m ³ /h
Manometric heads of up to:	55 m
Max. operating pressure:	10 bar
Max. temperature:	+35°C
DN suction:	G1 - G1 ^{1/4}
DN discharge:	G1

HYDROMINI HYDROSON

DOMESTIC BOOSTER PUMPS 2 pole - 50 Hz

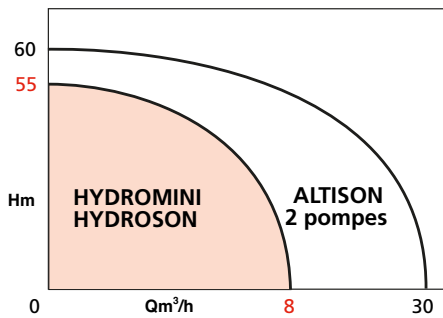

APPLICATIONS

Automatic distribution of pressurised water for domestic use:

- Water supply-distribution from a well, spring or storage tank.
- Irrigation - Watering.

- Raising the pressure of a weak mains system (if total pressure exceeds 4 bar: use the 8-litre tank).

For houses, rural dwellings, small farms, small-scale industries...

ADVANTAGES

- Fully-assembled, wired and preset booster pumps, ready for use.
- Easy installation: one electrical connection and two hydraulic couplings.
- Corrosion-proof components.
- Interchangeable butyl, food-grade bladder tank.
- Integrated thermal protection on all models.
- Easy, low-cost operation and maintenance.

Certified
ACS

• HYDROMINI HYDROSON

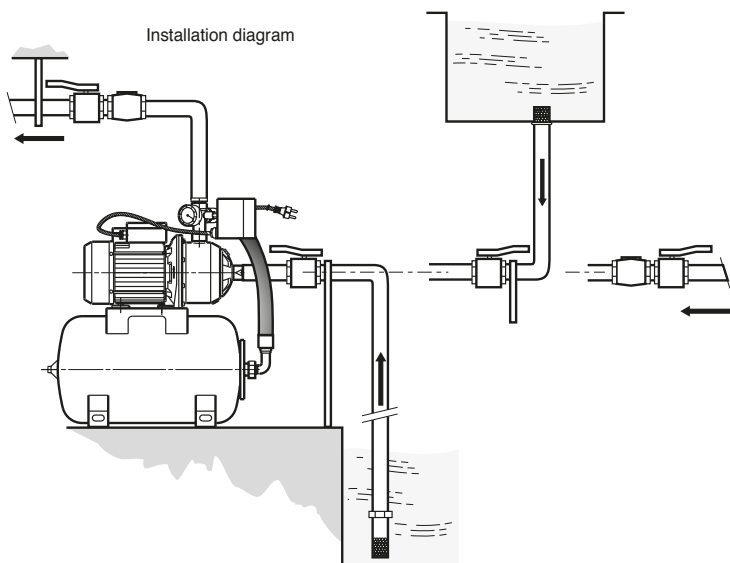
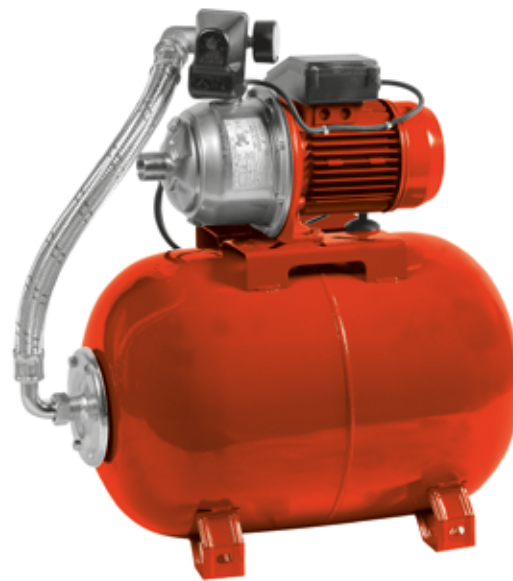

• HYDROMINI HYDROSON
- 8-litre tank

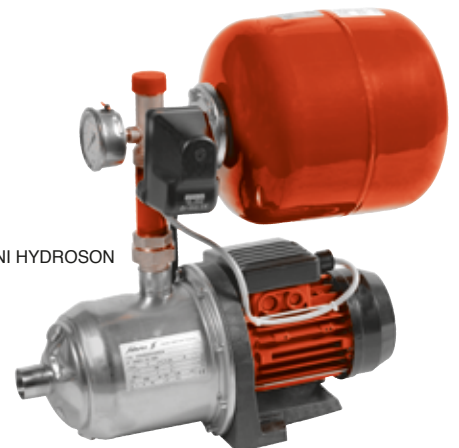

HYDROMINI HYDROSON

DESIGN

Pre-assembled, ready-to-install automatic booster pumps, equipped with:

- HYDROSON single-phase pump (204; 205; 405),
- Interchangeable bladder tank (8, 20, 50 and 100 l),
- Filler plug
- Drain plug
- Electric cable and plug
- Pump/tank connection hose
- Inflation valve
- Pressure gauge and pressure switch.
- Built-in thermal protection in winding
- automatic reset after cooling.

Factory preset on-off pressure settings on the contactor or pressure switch.

STANDARDS: EN 60.335.2.41

OPTIONS AND ACCESSORIES

- Foot valve - strainer (max. flow section 1 mm).
- 1/4-turn valve on suction line.
- 1/4-turn valve on discharge line.
- Non-return valve.
- Piping mount.
- Low-water protection kit protection (connection to mains supply).
- Float switch or pressure switch

- Low-water protection kit for connecting HYDROMINI to the mains supply.



HYDRAULIC PERFORMANCE

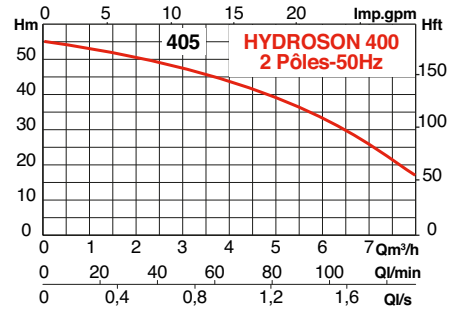
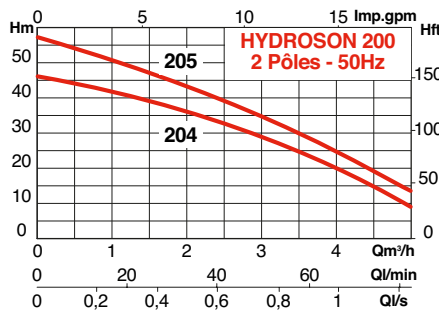

ELECTRICAL AND DIMENSIONAL SPECIFICATIONS

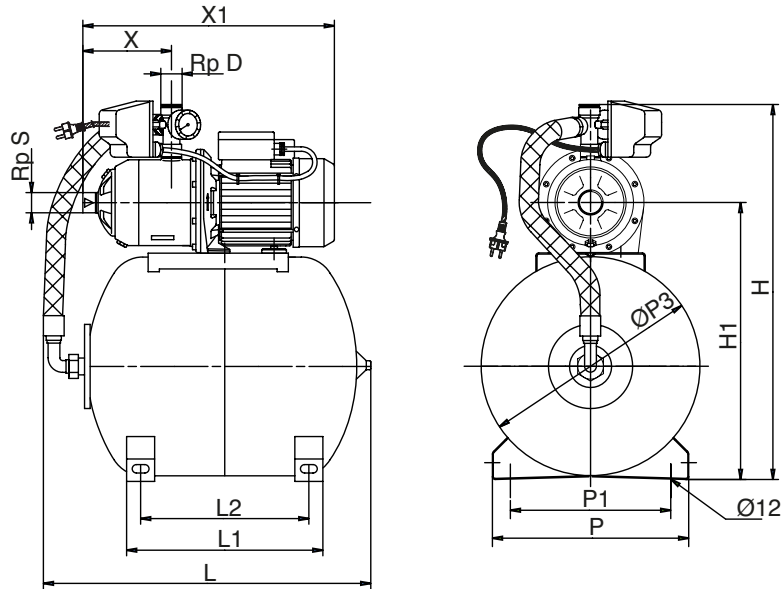

ORDER REFERENCE	Pump	Volume L	H mm	L mm	P mm	H1 mm	L1 mm	L2 mm	P1 mm	X mm	X1 mm
HY-204-M-H-20	HY-204	20	570	500	280	385	220	170	230	158	423
HY-204-M-H-50	HY-204	50	655	700	360	470	350	300	280	158	423
HY-204-M-H-100	HY-204	100	760	820	320	585	370	310	260	158	423
HY-205-M-H-50	HY-205	50	655	700	360	470	350	300	280	158	423
HY-205-M-H-100	HY-205	100	760	820	320	585	370	310	260	158	423
HY-405-M-H-100	HY-405	100	760	820	320	585	370	310	260	158	448

TANKS

Mean flow rate: 2 000 à 8 000 l/h

Capacity: 20 à 100 l

Max. tank pressure: 10 bar

