

Pump series MFP3

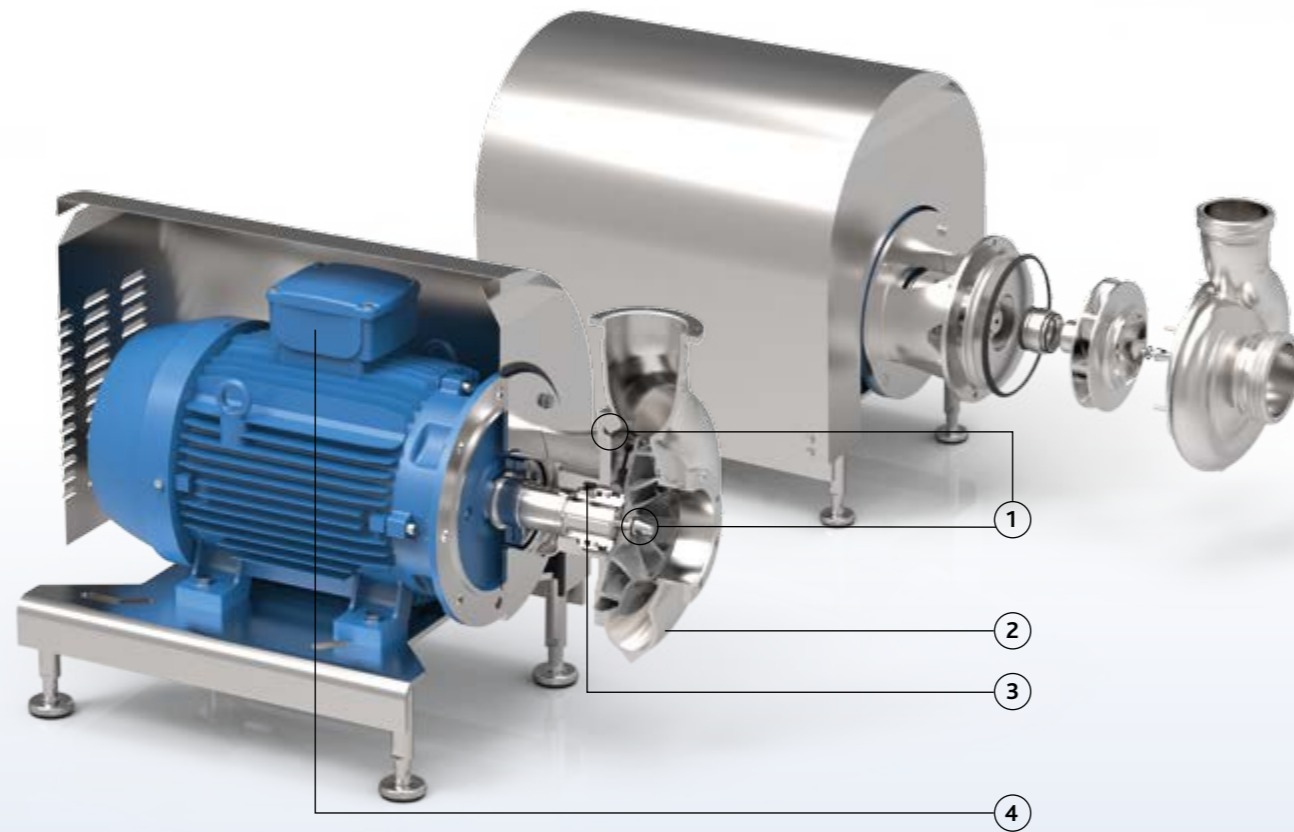

Characteristics

The Packo pumps of the MFP3 series are used on the most demanding hygienic applications in almost all industries such as dairies, breweries, beverage industry, distilleries, etc. These robust pumps have stainless steel 316L cast pump casings and closed investment cast impellers, constructed in 316L or duplex materials. Thanks to its crevice-free design and electropolishing as a final surface treatment, the MFP3 pump series are the ideal reliable component for your production process.



MFP3

- 1 Electropolished, easy to clean construction, no bacteria traps and no small clearances in order to clean the area around the O-ring
- 2 Solid design thanks to investment cast casings and impellers
- 3 Large seal cavity to clean mechanical seal properly
- 4 Monobloc execution with std. IEC motors
- 5 Standardized mechanical seals to EN 12756
FDA approved bellow mechanical seals or sterile O-ring seals (spring not in contact with the liquid)
- 6 Mechanical seal diameters depending on motor power: 43 - 70 - 110 mm

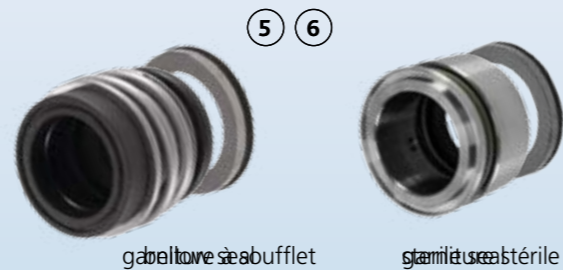

Your benefits

- High pump efficiency resulting in lower energy consumption
- Low NPSH values: less risk on cavitation
- Electropolished: easy to clean
- Easy construction and easy maintenance: less downtime
- Standard components
- Easy to install
- Robust construction

Application areas

These robust process pumps are the ideal reliable component for filtration applications, pasteurization, yeast propagation as well as for CIP cleaning systems. Typical applications include filtration of beer, wine and fruit juices as well as pumping yeast, whey, curd, CIP, etc.

| Pump series | MFP3 |
|---------------------------------|--|
| Performance | |
| max. flow rate | 1200 m ³ /h * |
| max. differential head | 70 m |
| max. discharge pressure | 12 bar |
| max. liquid viscosity | 500 cP |
| max. temperature | 140°C |
| impeller type | closed with back vanes and balancing holes |
| max. free passage | 27 mm |
| max. motor power | 250 kW |
| max. speed | 3000/3600 |
| available frequency | 50/60 Hz |
| Technical specifications | |
| materials wetted parts | stainless steel 316L or similar |
| mechanical seal configuration | single, quench, double |
| available material o-ring | EPDM, FKM, FEP-FKM, FFKM, Silicone |
| connections | hygienic fittings |
| surface finish | food quality, internal welds hand polished + electropolished |
| certificates & legislation | |

* Higher capacities up to 1700 m³/h available in industrial range (industrial fittings and welds not hand-polished).

Performance curves

MFP3

