

# Pump series ICP3

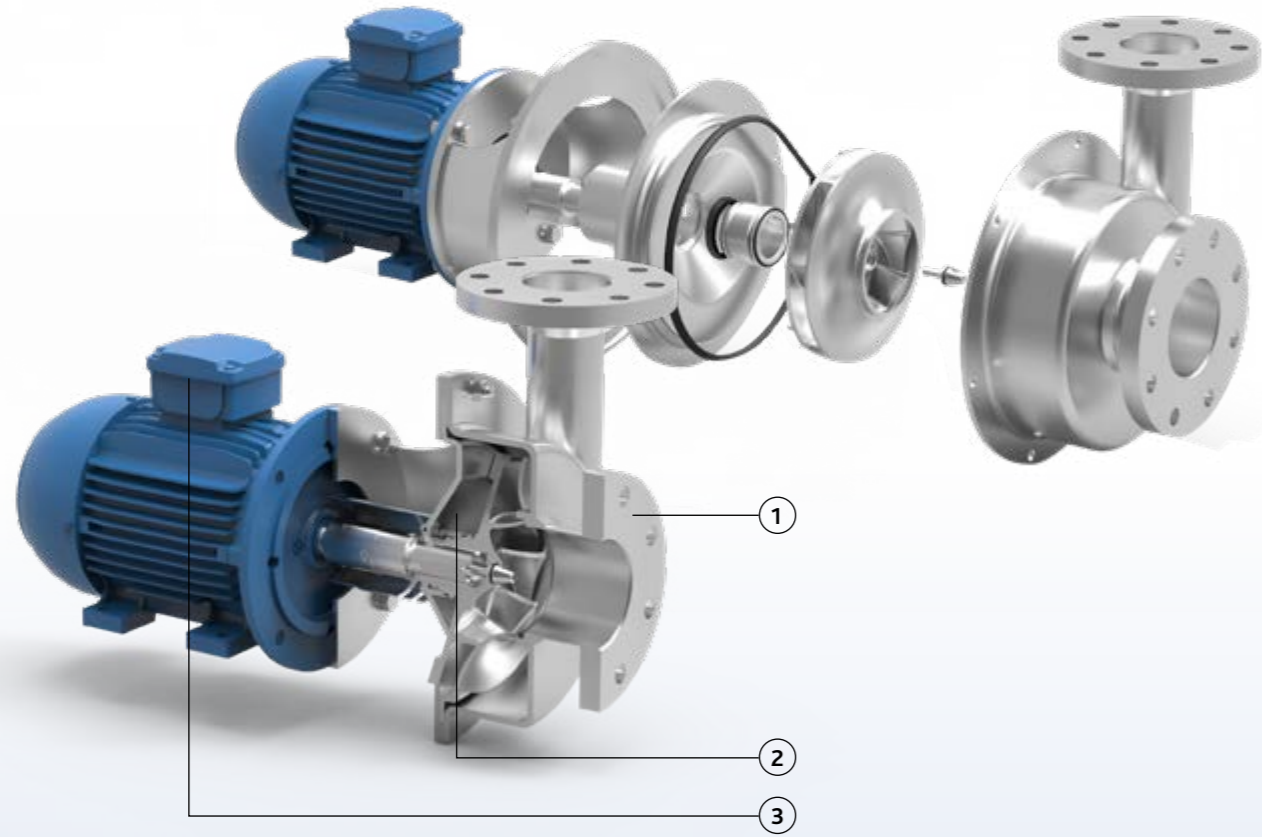

## Characteristics

These robust pumps have stainless steel 316L pump casings constructed in thick cold rolled plate and have closed investment cast impellers in duplex materials. Thanks to its solid construction and electropolished design these pumps are the reliable component for your production process.



### ICP3

- 1 Pressed stainless steel, pump casing thickness up to 8 mm, back plate up to 30 mm
- 2 Large seal cavity to guarantee liquid circulation around the seal
- 3 Monobloc execution with std. IEC motors
- 4 Standardized mechanical seals to EN 12756  
FDA approved bellow mechanical seals or balanced O-ring seals
- 5 2 seal diameters for the entire range:
  - motor power > 22 kW 4p or 45 kW 2p:  $\varnothing$  70 mm
  - motor power < 22 kW 4p or 45 kW 2p:  $\varnothing$  43 mm



## Your benefits

- High pump efficiency resulting in lower energy consumption
- Low NPSH values: less risk on cavitation
- Electropolished: higher resistance against corrosion
- Easy & robust construction and easy maintenance: less downtime
- Easy to install
- Solid impellers compared to low cost spot welded versions
- 2 mechanical seal diameters for entire range
- Standard components

## Application areas

The Packo pumps of the series ICP3 are used in a wide range of industries and applications.

You can find them in just about all industries such as vegetable industry, breweries, water treatment and textile industry as well as in e.g. biogas, biodiesel and bioethanol applications.

Typical liquids: blanching water, mash, wort, process and contaminated water, biodiesel, bioethanol, alcohols, CIP, biogas, etc.

Pump series	ICP3
<b>Performance</b>	
max. flow rate	320 m <sup>3</sup> /h
max. differential head	120 m
max. discharge pressure	15 bar
max. liquid viscosity	1000 cP
max. temperature	140°C
impeller type	closed with back vanes and balancing holes
max. free passage	21 mm
max. motor power	90 kW
max. speed	3000/3600 rpm
available frequency	50/60 Hz
<b>Technical specifications</b>	
materials wetted parts	stainless steel 316L or similar
mechanical seal configuration	single bellow, single balanced, quench, double, pressurized barrier
available O-ring materials	EPDM, FKM, FEP-FKM, FFKM, Silicone
connections	BSP fittings, flanges according to EN1092-1/01 & 02, ANSI flanges, smooth tubes
surface finish	industrial, welds not hand polished, electropolished
certificates & legislation	

## Performance curves at 2900 rpm

