

EBARA

	Page
- SPECIFICATIONS	200
PERFORMANCE RANGE	201
SELECTION CHART	202
TYPE KEY and CURVE SPECIFICATIONS	203
PERFORMANCE CURVE LPS 25/08	205
PERFORMANCE CURVE LPS 25/15	206
PERFORMANCE CURVE LPS 25/25	207
PERFORMANCE CURVE LPS 32/25	208
PERFORMANCE CURVE LPS 32/40	209
PERFORMANCE CURVE LPS 40/25	210
PERFORMANCE CURVE LPS 40/40	211
PERFORMANCE CURVE LPS 40/75	212
PERFORMANCE CURVE LPS 50/40	213
PERFORMANCE CURVE LPS 50/75	214
PERFORMANCE CURVE LPS 50/150	215
- CONSTRUCTIONS	300
SECTIONAL VIEW	300
SECTIONAL VIEW TABLE	301
MECHANICAL SEAL and BEARINGS	302
FITTINGS	303
- DIMENSIONS AND WEIGHT	400
PUMP	400
PACKING	401
- TECHNICAL DATA	500
MOTOR DATA	500
NOISE DATA	500
- INSTALLATION	600

SPECIFICATION

50Hz

Rev. M

PUMP		
Liquid Handled	Type of liquid	Clean water
	Temperature [°C]	min. -10 max. +100
Max environment temperature [°C]		40
Min suction pressure [MPa]		-0.6 at 35°C
Max positive suction pressure [MPa]		0.2 (All models single phase) 0.2 (LPS 25 three phase) 0.4 (LPS 32, 40, 50 three phase)
Construction	Impeller	Closed centrifugal
	Shaft seal type	Mechanical seal
	Bearing	Sealed ball bearing
Pipe Connection	Suction/Flange	From DN 25 up to DN 50
	Discharge/Flange	From DN 25 up to DN 50
Material	Casing	AISI 304
	Impeller	AISI 304
	Casing cover	AISI 304
	Shaft seal	Ceramic/Carbon/NBRH
	Shaft	AISI 303 (wet extension)
Applicable standard of test		ISO 9906:2012 – Grade 3B

MOTOR		
Type	Electric - TEFC	
	Single Phase	Three Phase
Efficiency level (Reg. 640/2009)	-	- from 0.08 kW up to 0.4 kW IE2 from 0.75 kW up to 1.5 kW IE3 from 0.75 kW up to 1.5 kW
No. of Poles	2	
Rotation speed [min ⁻¹]	≈ 2800	
Insulation Class	Class F	
Protection degree (CEI EN 60034-5)	IP 55	
Power rating	0.08 ÷ 1.5	
	0.1 ÷ 2	
Frequency [Hz]	50	
Voltage [V]	230 ±10%	230/400 ±10%
Capacitor	Built in	-
Over load protection	Built in	User to provide
Motor bracket	Aluminium	
Dimensions of cable entry	PG11 - PG13.5 – M16x1.5 – M20x1.5	

SELECTION CHART

50Hz

Rev. M

PERFORMANCE RANGE

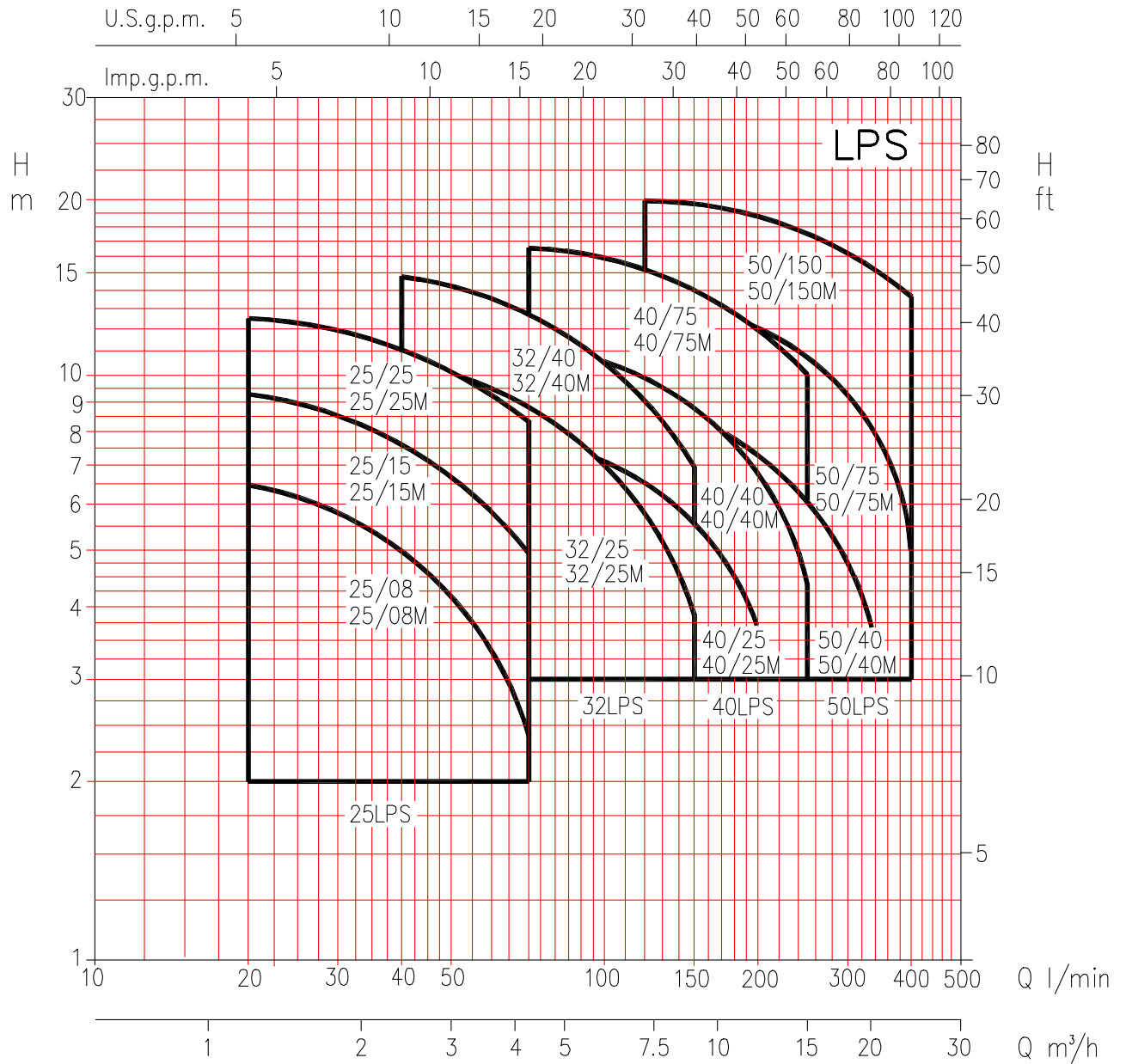

SELECTION CHART

Pump type		Power		Q=Capacity											
Single phase	Three phase	[kW]	[HP]	l/min	20	40	70	100	120	150	200	250	320	400	
				m ³ /h	1.2	2.4	4.2	6	7.2	9	12	15	19.2	24	
				H=Total manometric head in meters											
LPS 25/08M	LPS 25/08	0.08	0.1	7.2	6.5	5	2.4	-	-	-	-	-	-	-	
LPS 25/15M	LPS 25/15	0.15	0.2	10.3	9.3	7.8	4.9	-	-	-	-	-	-	-	
LPS 25/25M	LPS 25/25	0.25	0.33	13.7	12.5	11.1	8.4	-	-	-	-	-	-	-	
LPS 32/25M	LPS 32/25	0.25	0.33	12.0	-	10.7	9.1	7.2	5.9	3.9	-	-	-	-	
LPS 32/40M	LPS 32/40	0.4	0.5	16.4	-	14.5	12.7	10.6	9.2	7	-	-	-	-	
LPS 40/25M	LPS 40/25	0.25	0.33	7.9	-	-	7.8	7.1	6.6	5.6	3.7	-	-	-	
LPS 40/40M	LPS 40/40	0.4	0.5	11.8	-	-	11.3	10.4	9.9	8.7	6.9	4.4	-	-	
LPS 40/75M	LPS 40/75	0.75	1	17.3	-	-	16.6	16	15.2	14.1	12.3	10.1	-	-	
LPS 50/40M	LPS 50/40	0.40	0.5	9.8	-	-	-	-	9.1	8.8	7.4	5.9	3.5	-	
LPS 50/75M	LPS 50/75	0.75	1	14.8	-	-	-	-	13.8	13.3	12.3	10.7	8.2	5	
LPS 50/150M	LPS 50/150	1.5	2	20.7	-	-	-	-	19.8	19.3	18.7	17.8	16	13.7	

TYPE KEY

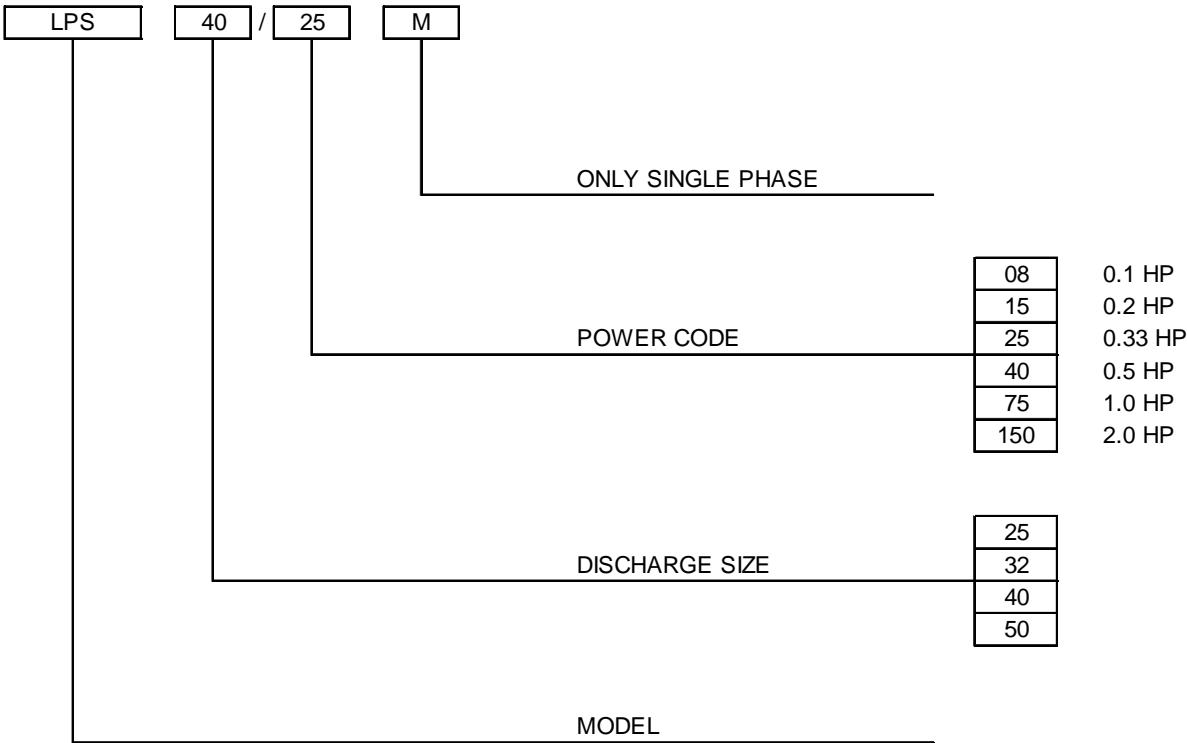

PERFORMANCE CURVE SPECIFICATIONS

The specifications below qualify the curves shown on the following pages.

Tolerances according to ISO 9906:2012 – Grade 3B

The curves refer to effective speed of asynchronous motors at 50 Hz, 2 poles.

Measurements were carried out with clean water at 20°C of temperature and with a kinematic viscosity of $\nu = 1 \text{ mm}^2/\text{s}$ (1 cSt)

The continuous curves indicate the recommended working range. The dotted curve is only a guide.

In order to avoid the risk of over-heating, the pumps should not be used at a flow rate below 10% of best efficiency point.

Symbols explanation:

- Q = volume flow rate
- H = total head
- P_2 = pump power input (shaft power)
- η = pump efficiency
- MEI = minimum efficiency index

The minimum efficiency index (MEI) is a measure of the quality of a pump size in respect to its mean efficiency. The minimum efficiency index is based on the hydraulic efficiency and on the head at the best efficiency point.

The benchmark for most efficient water pumps is $MEI \geq 0,70$.

Information on benchmark efficiency is available at: www.ebara-europe.com

The efficiency of a pump with trimmed impeller is usually lower than that of a pump with the full impeller diameter. The trimming of the impeller will adapt the pump to a fixed duty point, leading to a reduced energy consumption. The minimum efficiency index (MEI) is based on the full impeller diameter.

The operation of these water pumps with variable duty points may be more efficient and economical when controlled, for example, by the use of a variable speed drive that matches the pump duty to the system.

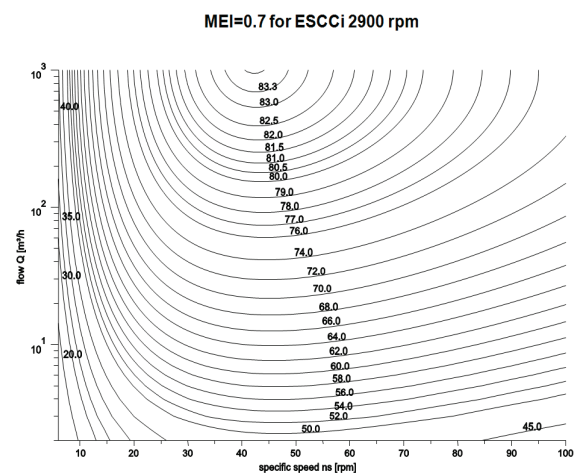
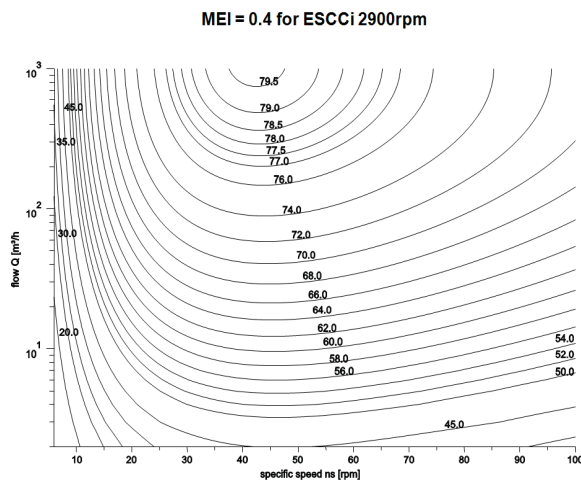

LPS 25/08 (0.08 kW) - LPS 25/08M (0.08 kW) - Impeller diameter = 84 mm

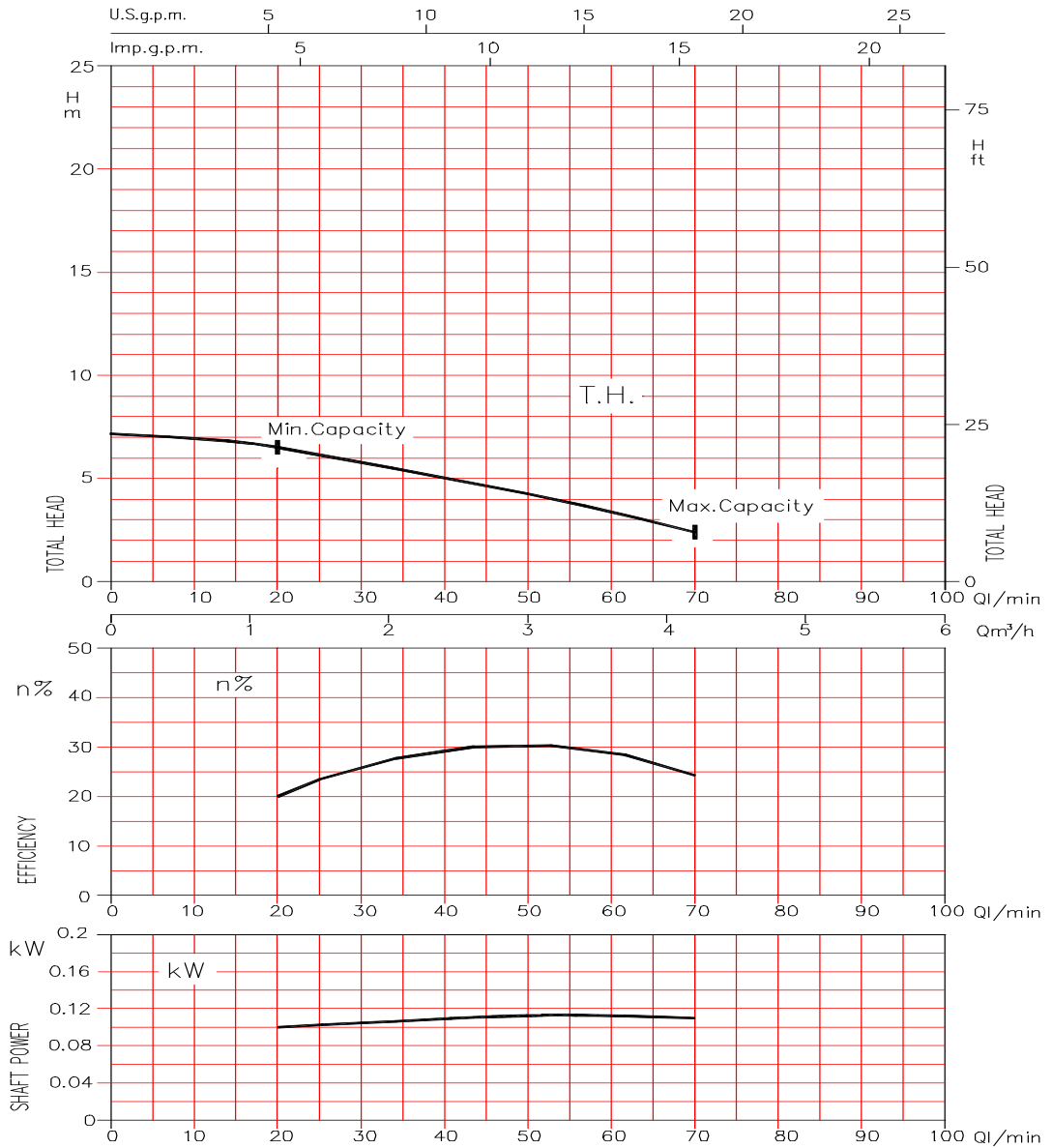

Rotation speed ≈ 2800 min⁻¹
 Test standard: ISO 9906:2012 – Grade 3B

LPS 25/15 (0.15 kW) - LPS 25/15M (0.15 kW) - Impeller diameter = 98 mm

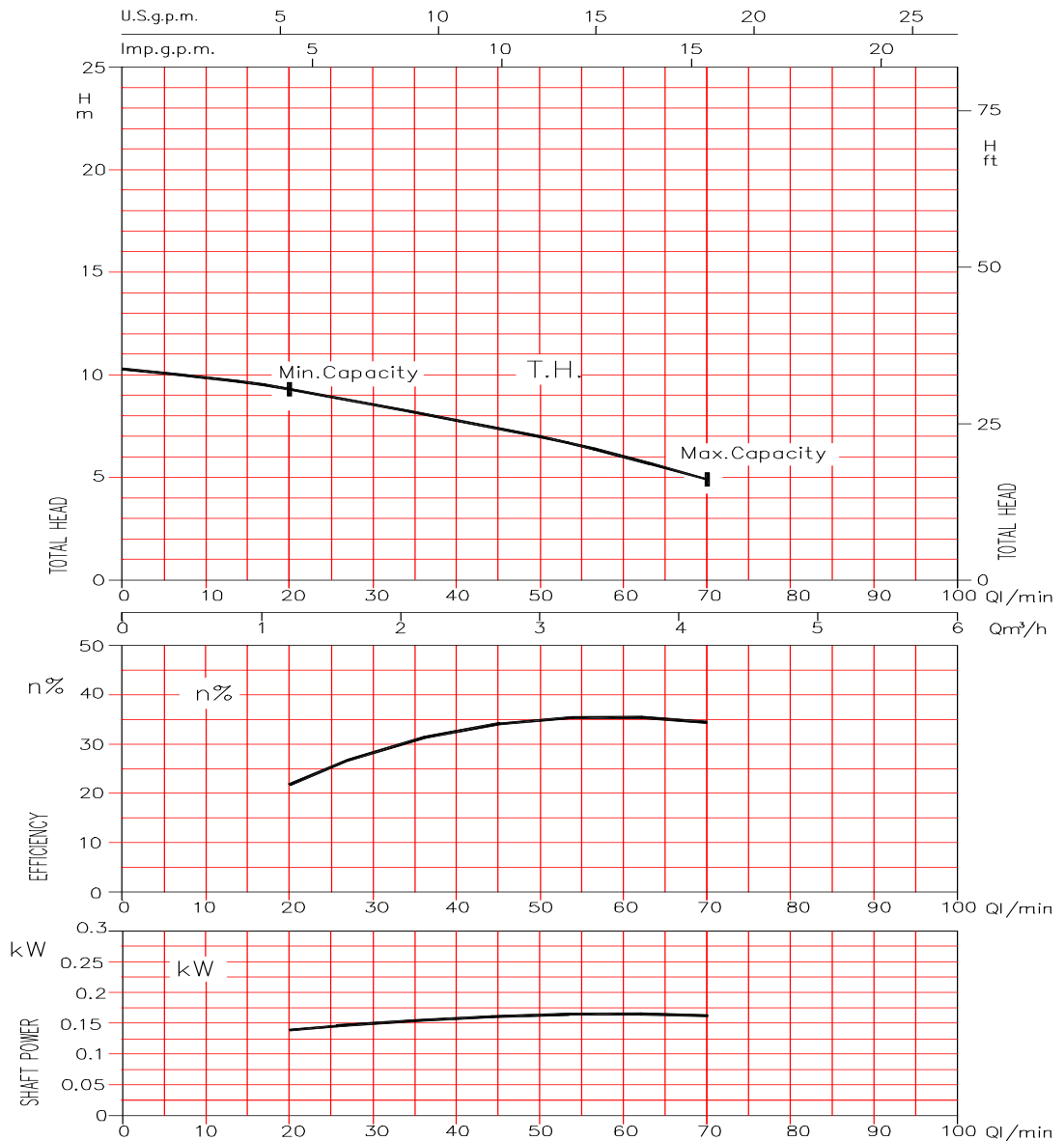

Rotation speed ≈ 2800 min⁻¹
 Test standard: ISO 9906:2012 – Grade 3B

LPS 25/25 (0.25 kW) - LPS 25/25M (0.25 kW) - Impeller diameter = 114 mm

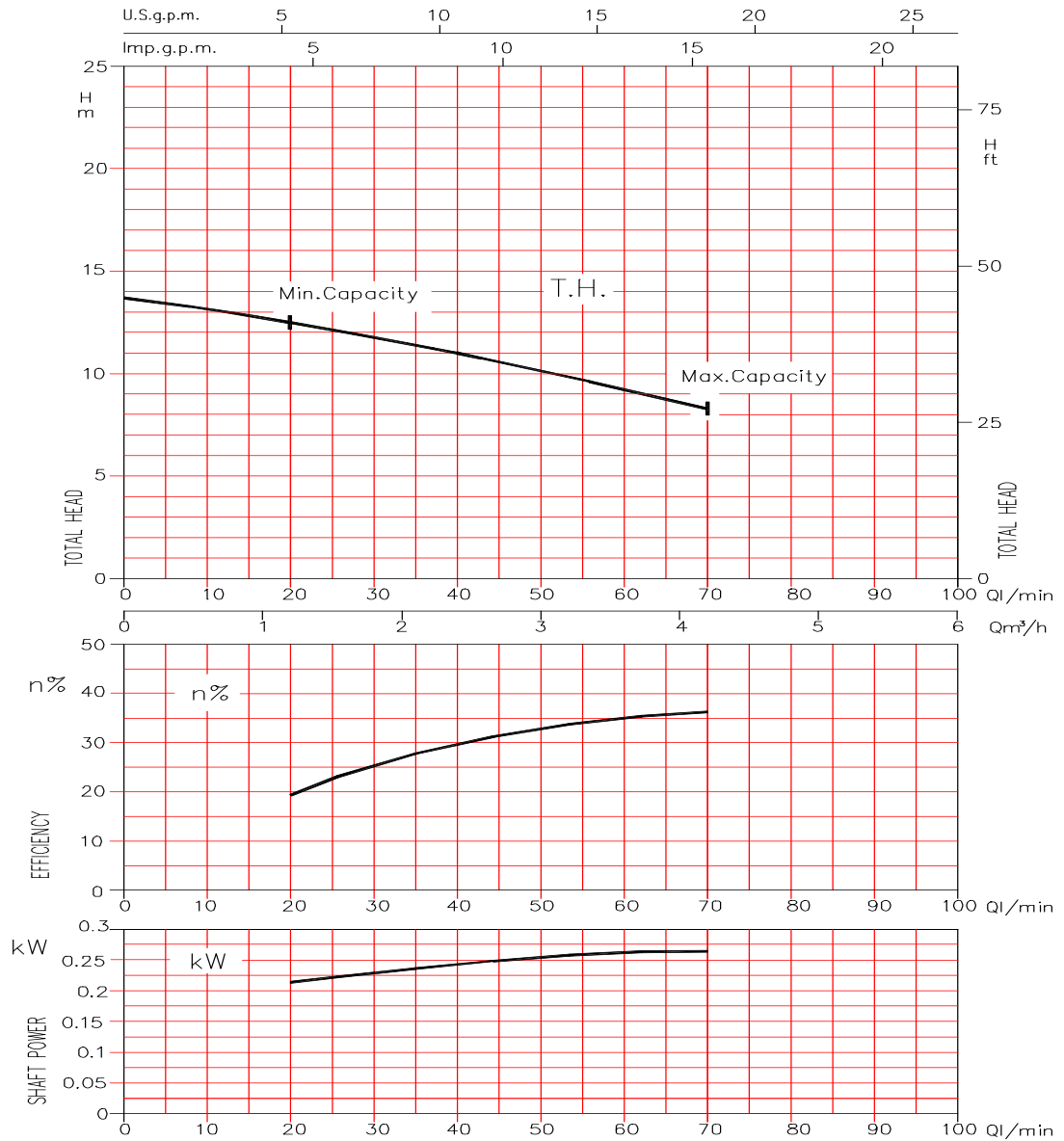

Rotation speed ≈ 2800 min⁻¹
 Test standard: ISO 9906:2012 – Grade 3B

LPS 32/25 (0.25 kW) - LPS 32/25M (0.25 kW) - Impeller diameter = 103 mm

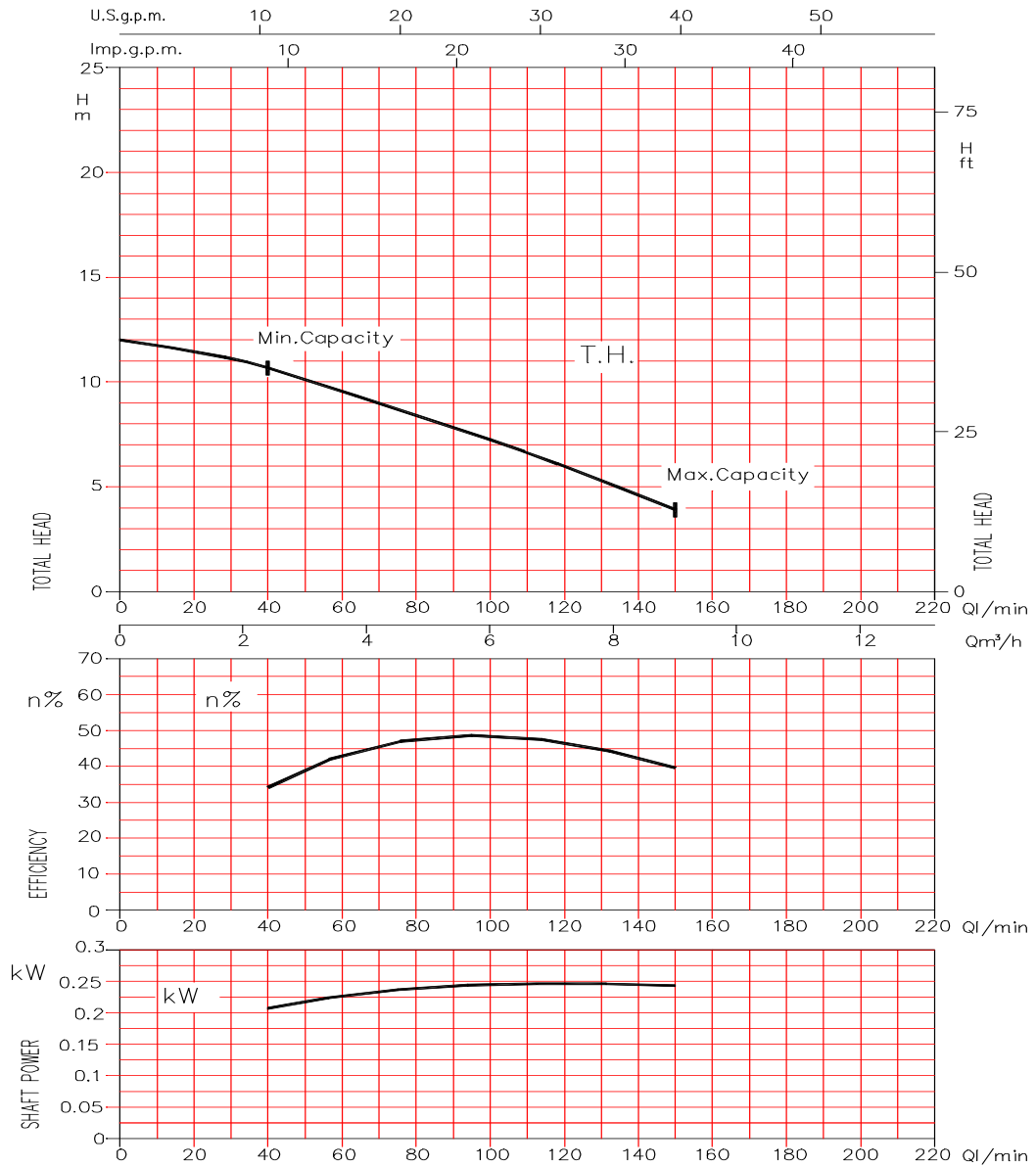

Rotation speed $\approx 2800 \text{ min}^{-1}$
 Test standard: ISO 9906:2012 – Grade 3B

LPS 32/40 (0.4 kW) - LPS 32/40M (0.4 kW) - Impeller diameter = 124 mm

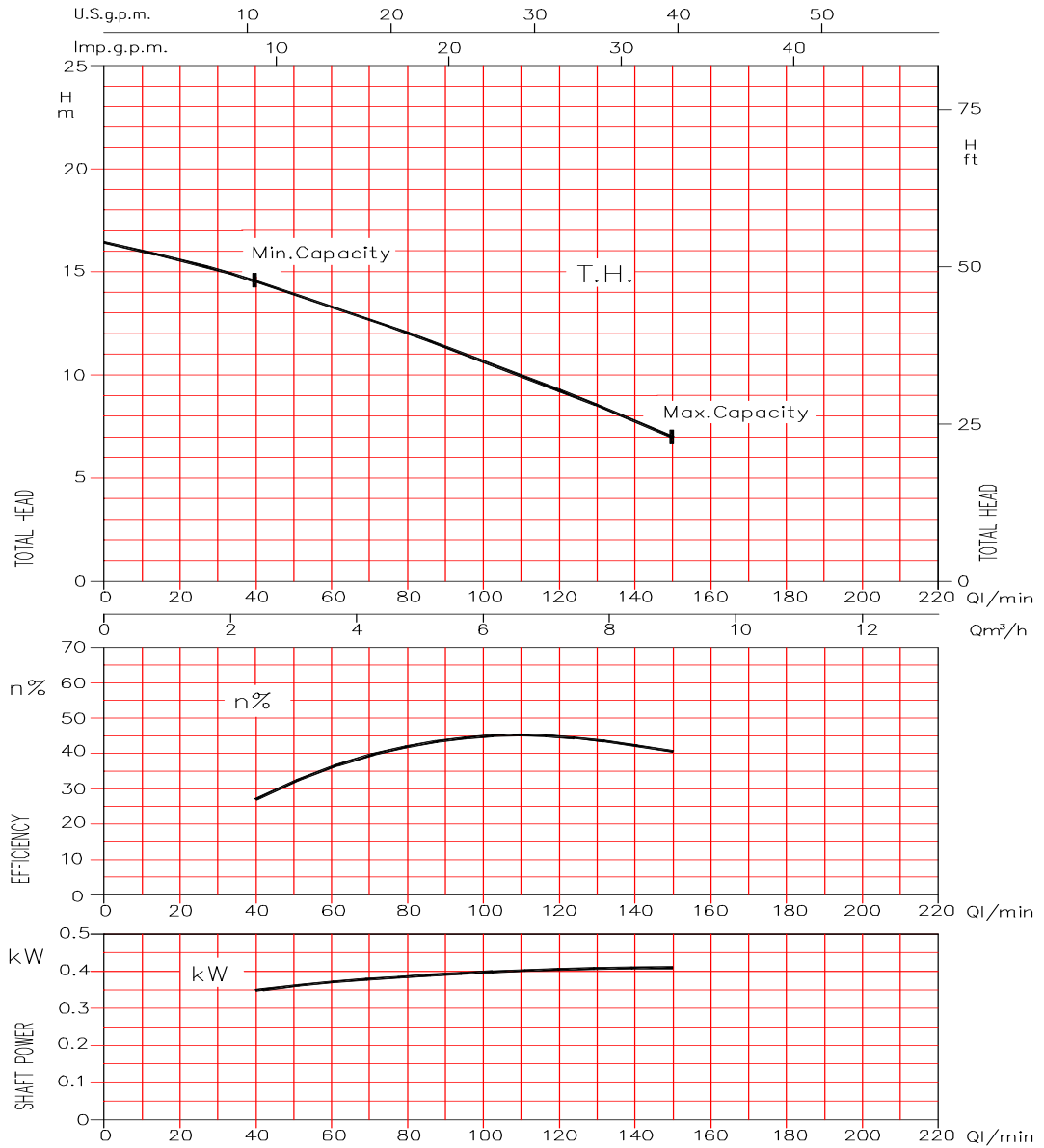

PRODUCT NOT AVAILABLE FOR THE EUROPEAN MARKET

Rotation speed ≈ 2800 min⁻¹
 Test standard: ISO 9906:2012 – Grade 3B

LPS 40/25 (0.25 kW) - LPS 40/25M (0.25 kW) MEI > 0.40 - Impeller diameter = 86 mm

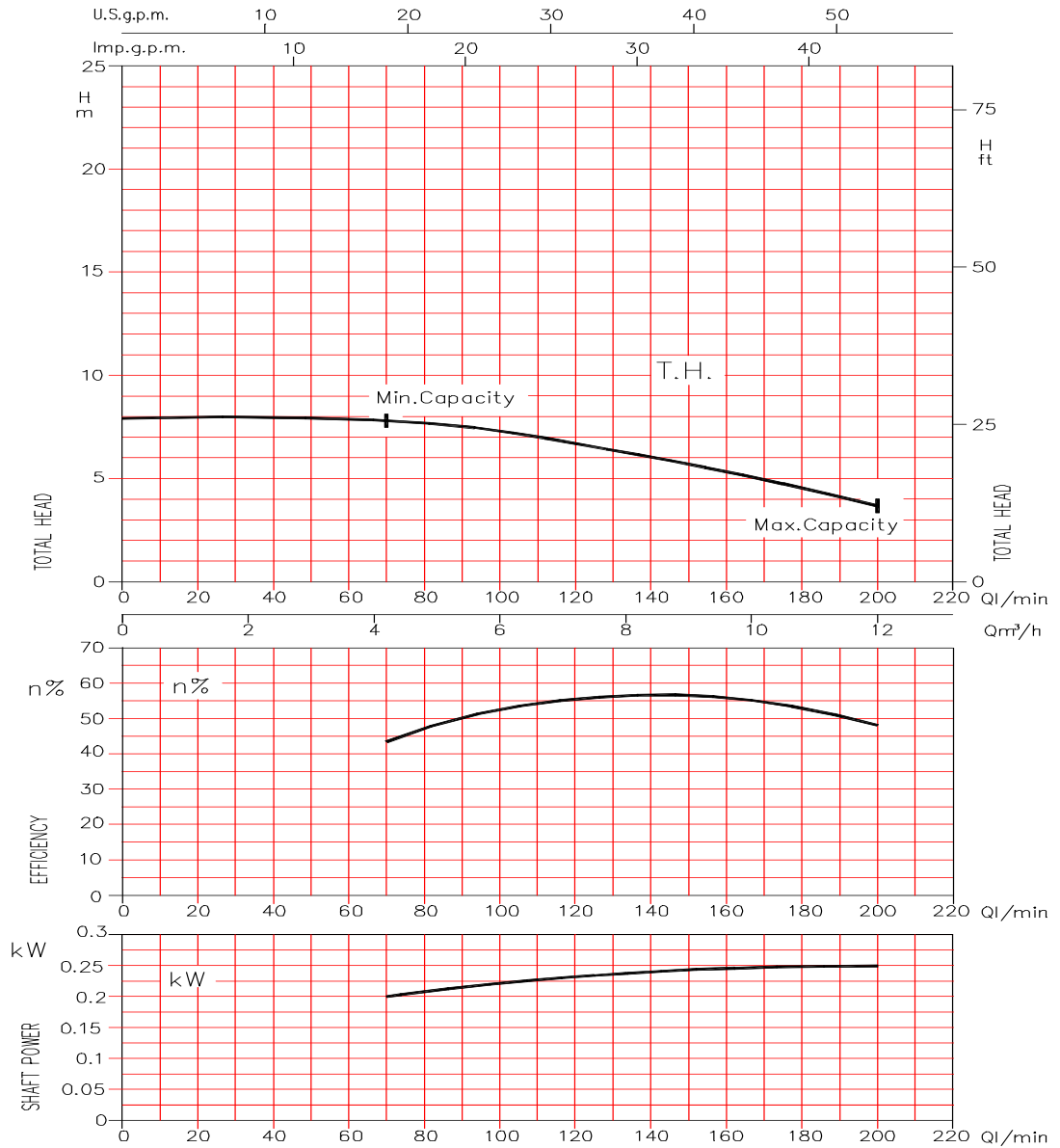

Rotation speed ≈ 2800 min⁻¹
 Test standard: ISO 9906:2012 – Grade 3B

LPS 40/40 (0.4 kW) - LPS 40/40M (0.4 kW) - Impeller diameter = 103 mm

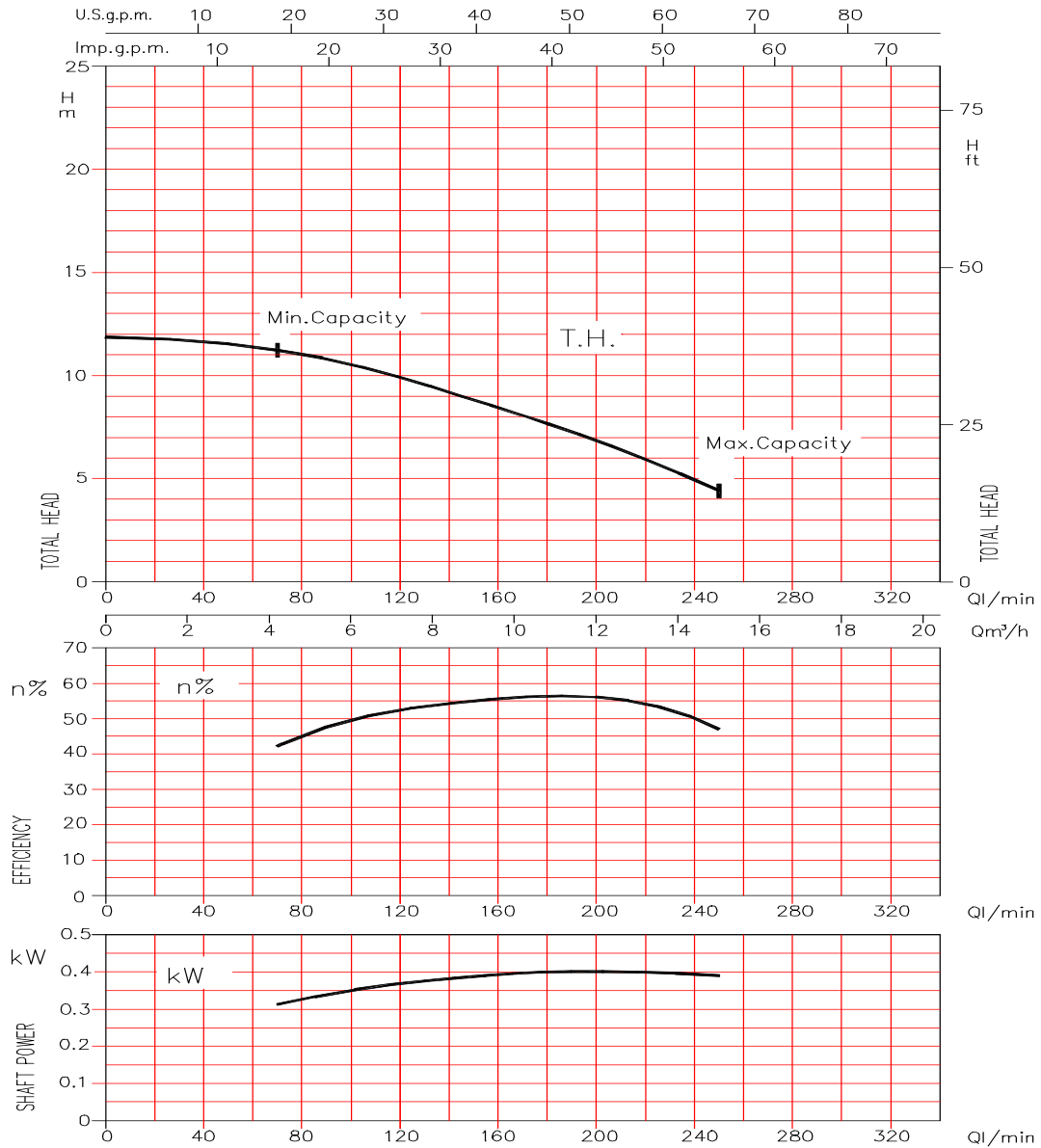

PRODUCT NOT AVAILABLE FOR THE EUROPEAN MARKET

Rotation speed ≈ 2800 min⁻¹
 Test standard: ISO 9906:2012 – Grade 3B

LPS 40/75 (0.75 kW) - LPS 40/75M (0.75 kW) - Impeller diameter = 124 mm

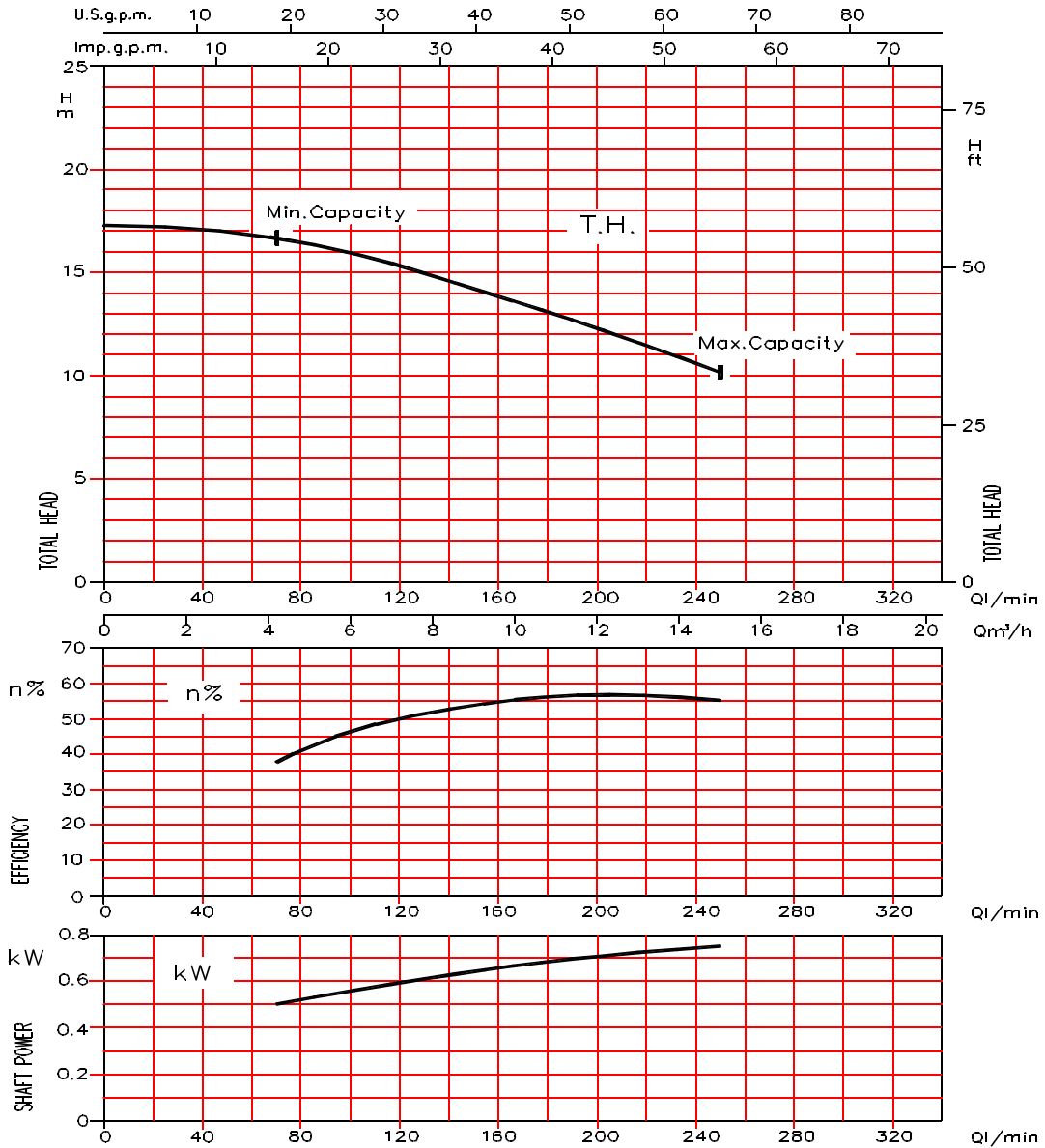

PRODUCT NOT AVAILABLE FOR THE EUROPEAN MARKET

Rotation speed ≈ 2800 min⁻¹
 Test standard: ISO 9906:2012 – Grade 3B

LPS 50/40 (0.4 kW) - LPS 50/40M (0.4 kW) - Impeller diameter = 95 mm

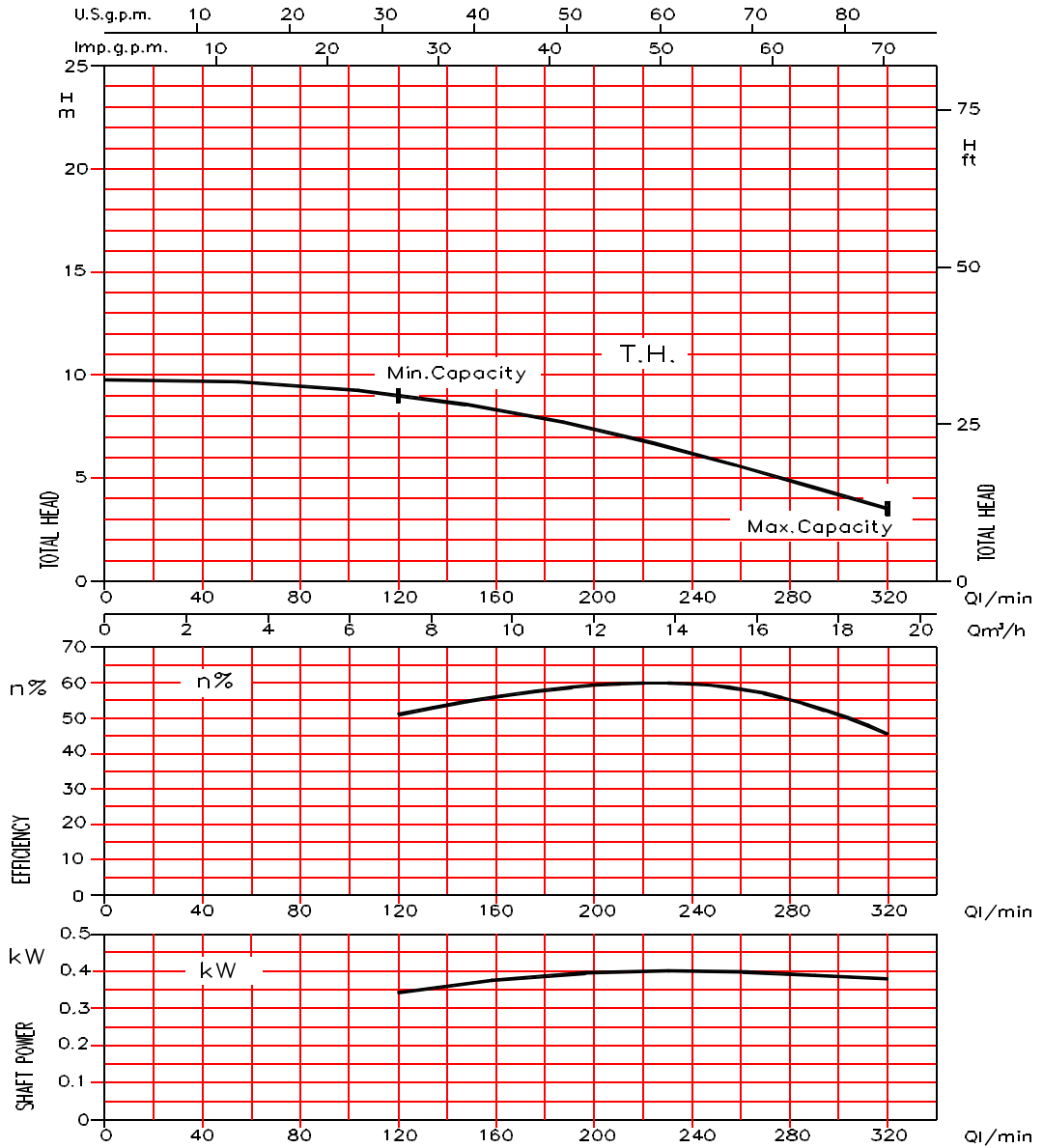

PRODUCT NOT AVAILABLE FOR THE EUROPEAN MARKET

Rotation speed ≈ 2800 min⁻¹
 Test standard: ISO 9906:2012 – Grade 3B

LPS 50/75 (0.75 kW) - LPS 50/75M (0.75 kW) - Impeller diameter = 114 mm

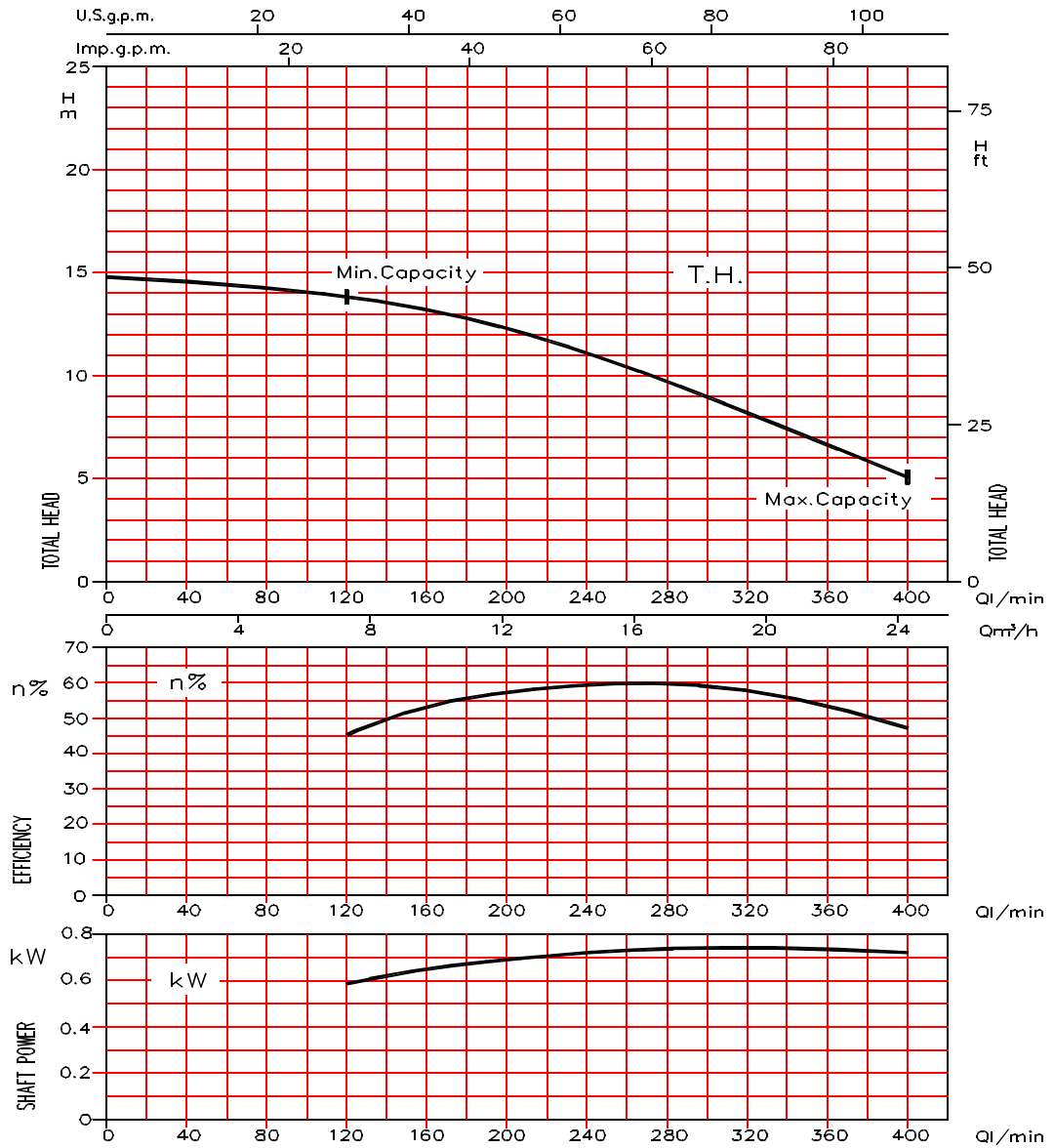

PRODUCT NOT AVAILABLE FOR THE EUROPEAN MARKET

Rotation speed ≈ 2800 min⁻¹
 Test standard: ISO 9906:2012 – Grade 3B

LPS 50/150 (1.5 kW) - LPS 50/150M (1.5 kW) - Impeller diameter = 129 mm

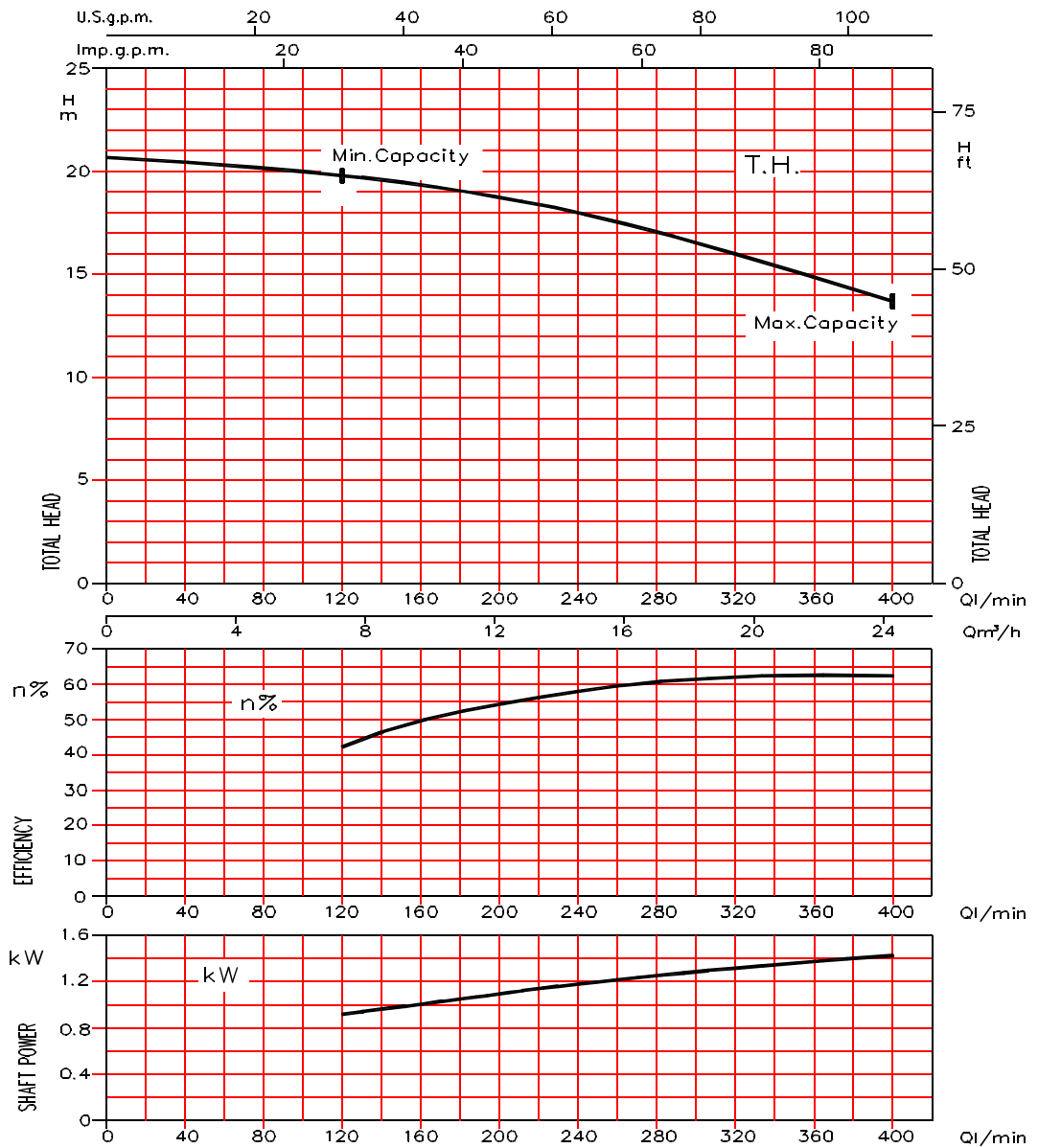

PRODUCT NOT AVAILABLE FOR THE EUROPEAN MARKET

Rotation speed ≈ 2800 min⁻¹
 Test standard: ISO 9906:2012 – Grade 3B

SECTIONAL VIEW

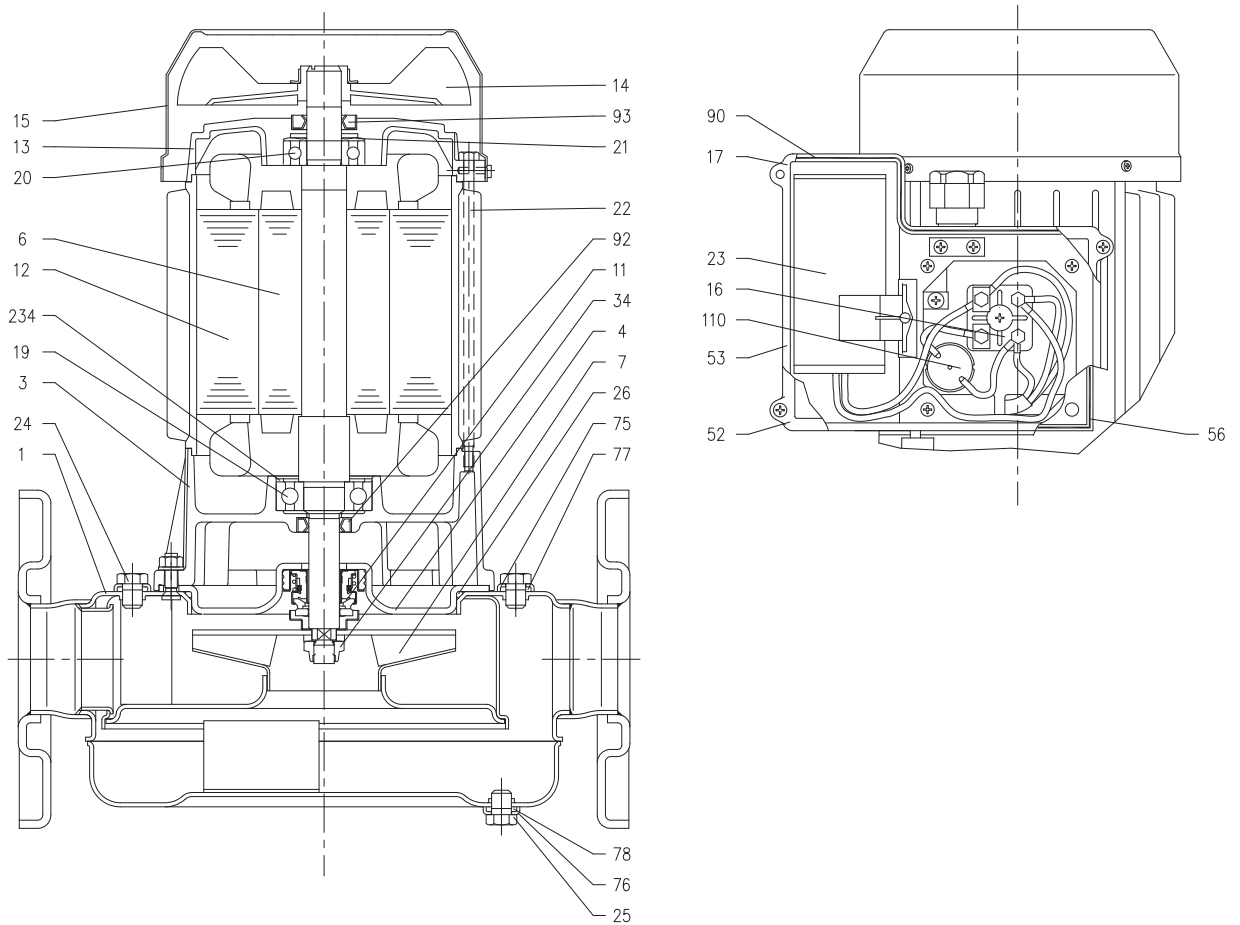

SECTIONAL VIEW TABLE

N°	PART NAME	MATERIAL	DIMENSION	STANDARD	Q.TY
1	Casing	AISI 304			1
3	Motor bracket	Aluminium			1
4	Casing cover	AISI 304			1
6	Shaft with rotor	AISI 303 (Wet extension)			1
7	Impeller	AISI 304			1
11	Mechanical seal	Carbon/Ceramic/NBRH	See page 302		1
12	Motor frame with stator	-			1
13	Motor cover	Aluminium			1
14	Fan	PA			1
15	Fan cover	Fe P04 Galvanized			1
16	Terminal board	-			1
17	Terminal box cover [2]	Aluminium			1
19	Pump side ball bearing	-			1
20	Fan side ball bearing	-			1
21	Adjusting ring	Steel C70			1
22	Tie rod	Fe 420 Galvanized			4
23	Capacitor [1]	-			1
24	Priming plug	AISI 304	1/8" G	ISO 228/2	2
25	Drain plug	AISI 304	1/8" G	ISO 228/2	1
26	O-ring	NBR			1
34	Impeller nut	AISI 304	M10x1.25	UNI 7474	1
52	Capacitor box [1]	ABS class V-0			1
53	Capacitor box cover [1]	ABS class V-0			1
56	Box gasket	NBR			1
75	Washer	AISI 304			2
76	Washer	AISI 304			1
77	O-ring	NBR			2
78	O-ring	NBR			1
90	Terminal box cover gasket	NBR			1
92	Lip seal	NBR			1
93	Lip seal	NBR			1
110	Protector [3]	-			1
234	Seeger ring	Carbon steel			1

[1] Only for single phase

[2] Only for three phase

[3] Only for version single phase: LPS 50/150M

MECHANICAL SEAL

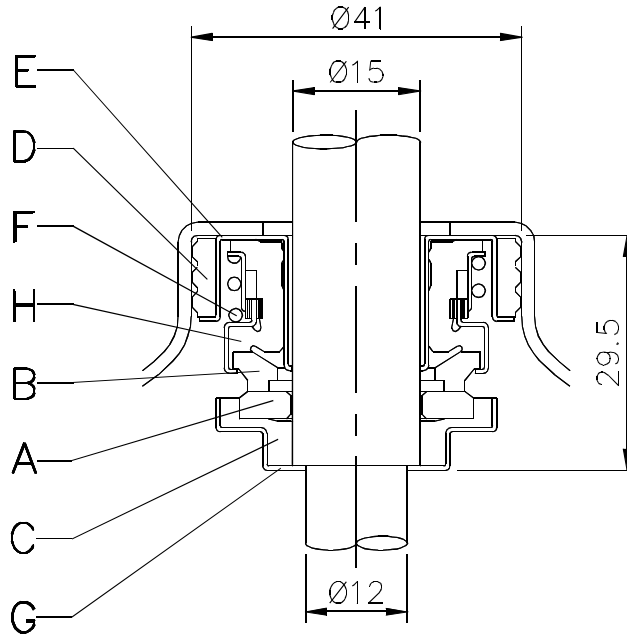

REF	PART NAME	MATERIAL
A	Rotary seal ring	Ceramic
B	Stationary seal ring	Carbon graphite
C	Cup Gasket	NBRH
D	Seat ring	NBRH
E	Case	AISI 304
F	Self driving spring	AISI 304
G	Case	AISI 304
H	Bellows	NBRH

BEARINGS

Pump type		Ball Bearing			
Single Phase	Three Phase	Pump side	(*) Pump side	Fan side	(*) Fan side
LPS 25/08M	LPS 25/08	6203-2RSH	6203-ZZ C3	6202-2RSH	6202-ZZ C3
LPS 25/15M	LPS 25/15				
LPS 25/25M	LPS 25/25				
LPS 32/25M	LPS 32/25				
LPS 32/40M	LPS 32/40				
LPS 40/25M	LPS 40/25				
LPS 40/40M	LPS 40/40				
LPS 40/75M	LPS 40/75				
LPS 50/40M	LPS 50/40				
LPS 50/75M	LPS 50/75				
LPS 50/150M	LPS 50/150	6204-2RSH	6204-ZZ C3	6203-2RSH	6203-ZZ C3

(*) Only for IE3 Motors

FITTINGS
COUNTER FLANGE

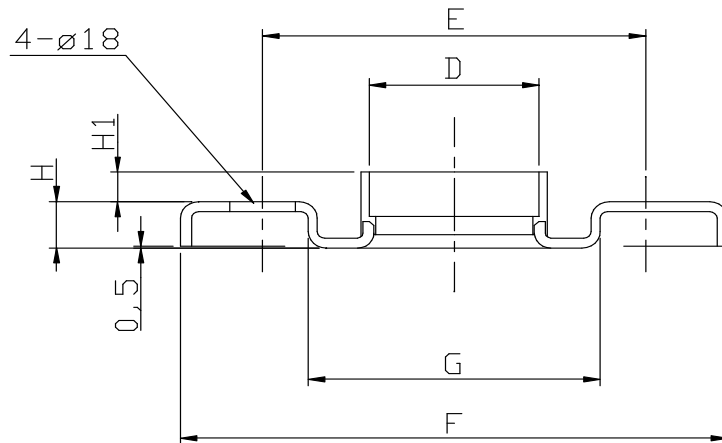

DIN	D	G	E	F	H	H1
25	G 1"	64	85	115	12	13
32	G 1" 1/4	76	100	140	14	11
40	G 1" 1/2	81	110	150	14	10.5
50	G 2"	96	125	165	16	14

Material : Galvanized steel for standard
AISI 304 upon request

GASKET

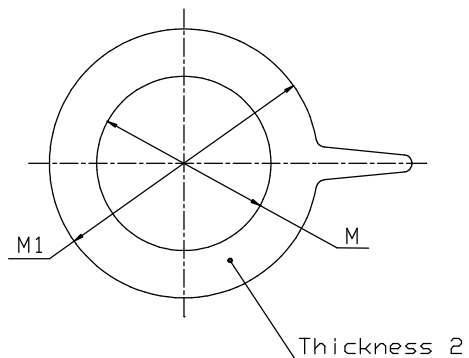

DIN	M	M1
25	30	70
32	38	82
40	50	93
50	60	107

Material : EPDM version for standard
VITON upon request

PUMP

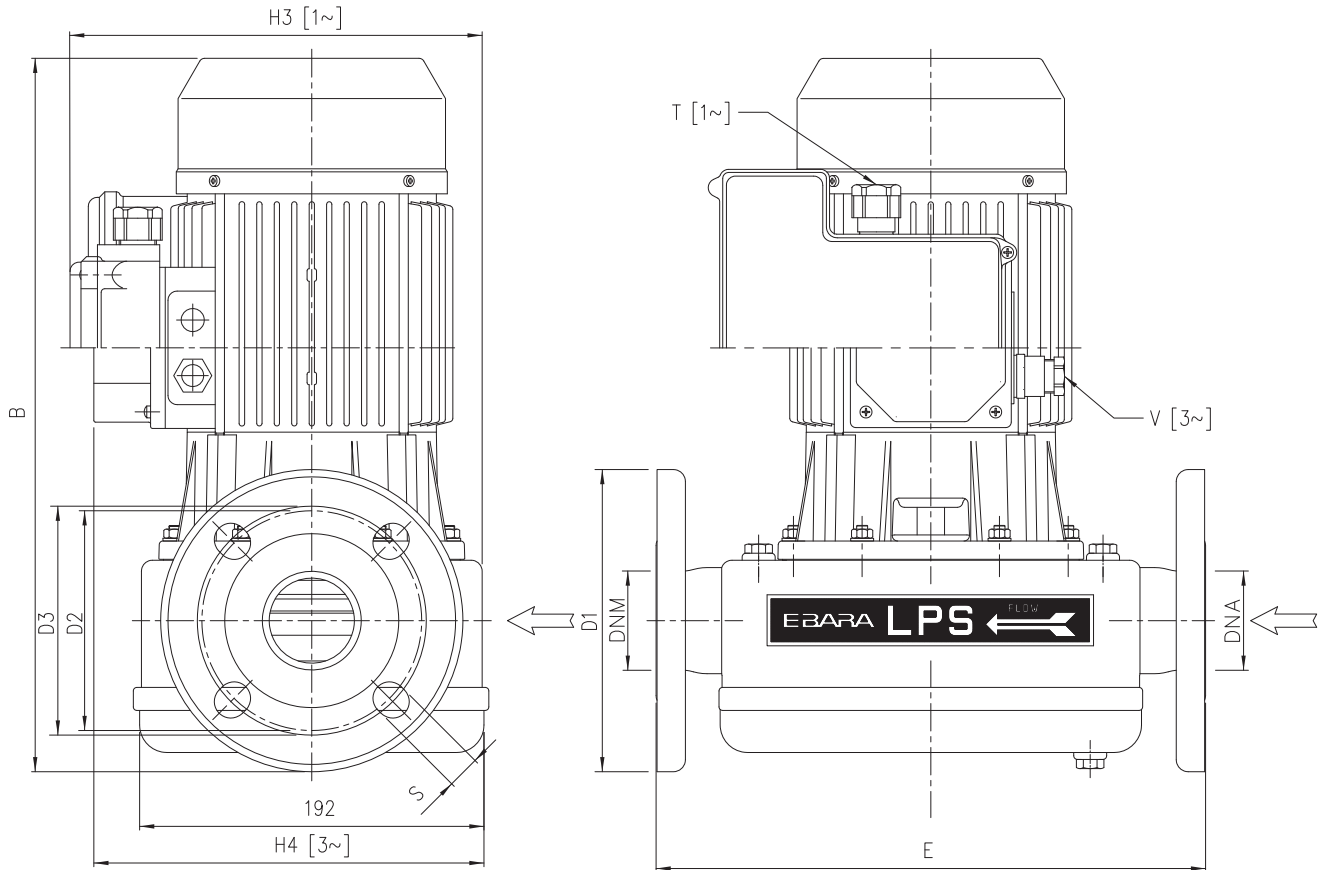

Pump type		Dimensions in mm															Weight [kgf]			
Single Phase [1~]	Three Phase [3~]	E	B			H3	H4	T	V			DNA	DNM	D1	D2	D3	S	[1~]	[3~]	(*)
			[1~]	[3~]	(*)	[1~]	[3~]	[1~]	[3~]	(*)										
LPS 25/08M	LPS 25/08	300	322	322	-	206	197.5	PG11	PG11	-	25	25	115	85	85	14	10	10	-	
LPS 25/15M	LPS 25/15	300	322	322	-	206	197.5	PG11	PG11	-	25	25	115	85	85	14	10	10	-	
LPS 25/25M	LPS 25/25	300	322	322	-	206	197.5	PG11	PG11	-	25	25	115	85	85	14	10.1	10.1	-	
LPS 32/25M	LPS 32/25	305	341.5	341.5	-	206	197.5	PG11	PG11	-	32	32	140	100	100	18	10.8	10.8	-	
LPS 32/40M	LPS 32/40	305	341.5	341.5	-	206	197.5	PG11	PG11	-	32	32	140	100	100	18	10.8	10.8	-	
LPS 40/25M	LPS 40/25	305	346.5	346.5	-	206	197.5	PG11	PG11	-	40	40	150	105	110	18	11	11	-	
LPS 40/40M	LPS 40/40	305	346.5	346.5	-	206	197.5	PG11	PG11	-	40	40	150	105	110	18	11	11	-	
LPS 40/75M	LPS 40/75	305	346.5	346.5	346.5	206	197.5	PG11	PG11	M16x1.5	40	40	150	105	110	18	13.7	13.7	13.7	
LPS 50/40M	LPS 50/40	310	356.5	356.5	-	206	197.5	PG11	PG11	-	50	50	165	120	125	18	11.6	11.6	-	
LPS 50/75M	LPS 50/75	310	356.5	356.5	356.5	206	197.5	PG11	PG11	M16x1.5	50	50	165	120	125	18	14.4	14.4	14.4	
LPS 50/150M	LPS 50/150	310	387	400	412.5	232	214.5	PG13.5	PG11	M20x1.5	50	50	165	120	125	18	17.7	19.6	20.5	

[1~] Single Phase

[3~] Three Phase

(*) Only for IE3 Motors

PACKING

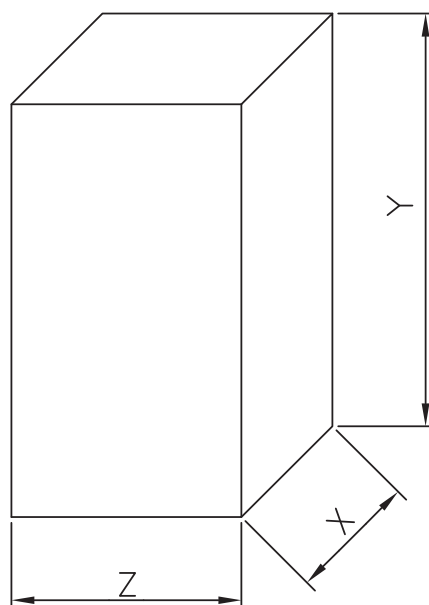

Pump type		Packing [mm]			Weight [kgf]		
Single phase	Three phase	X	Y	Z	[1~]	[3~]	(*) [3~]
LPS 25/08M	LPS 25/08	242	432	398	12.8	12.8	-
LPS 25/15M	LPS 25/15	242	432	398	12.8	12.8	-
LPS 25/25M	LPS 25/25	242	432	398	12.9	12.9	-
LPS 32/25M	LPS 32/25	242	432	398	14.6	14.6	-
LPS 32/40M	LPS 32/40	242	432	398	14.6	14.6	-
LPS 40/25M	LPS 40/25	242	432	398	15	15	-
LPS 40/40M	LPS 40/40	242	432	398	15	15	-
LPS 40/75M	LPS 40/75	242	432	398	18.2	18.2	18.2
LPS 50/40M	LPS 50/40	242	432	398	16	16	-
LPS 50/75M	LPS 50/75	242	432	398	19	19	19
LPS 50/150M	LPS 50/150	242	432	398	22.2	24.1	24.1

[1~] Single Phase

[3~] Three Phase

(*) Only for IE3 Motos

MOTOR DATA

Pump type		Power		Efficiency		Capacitor		Efficiency (% load)			Input		Full load current			Locked rotor current		
Single Phase	Three Phase	[kW]	[HP]	Single Phase	Three Phase	Single Phase		Three phase			Single Phase	Three Phase	[A]			[A]		
						[μF]	[V]	50%	75%	100%			230 V	230 V	400 V	230 V	230 V	400 V
LPS 25/08M	LPS 25/08	0.08	0.1	-	-	12.5	450	-	-	-	0.29	0.27	1.51	1.7	1.01	5.5	6.0	3.7
LPS 25/15M	LPS 25/15	0.15	0.2	-	-	12.5	450	-	-	-	0.34	0.33	1.67	1.8	1.03	5.5	6.0	3.7
LPS 25/25M	LPS 25/25	0.25	0.33	-	-	12.5	450	-	-	-	0.45	0.44	2.04	1.9	1.11	5.5	6.0	3.7
LPS 32/25M	LPS 32/25	0.25	0.33	-	-	12.5	450	-	-	-	0.43	0.41	2.0	1.8	1.03	5.5	6.0	3.7
LPS 32/40M	LPS 32/40	0.4	0.5	-	-	12.5	450	-	-	-	0.62	0.63	2.74	2.2	1.25	9.8	11.0	6.5
LPS 40/25M	LPS 40/25	0.25	0.33	-	-	12.5	450	-	-	-	0.43	0.42	1.98	1.9	1.09	5.5	6.0	3.7
LPS 40/40M	LPS 40/40	0.4	0.5	-	-	12.5	450	-	-	-	0.62	0.63	2.75	2.2	1.25	9.8	11.0	6.5
LPS 40/75M	LPS 40/75	0.75	1	-	IE2	25	450	77.2	80.9	81.3	1.07	0.92	4.86	3.0	1.7	20.3	22.0	12.9
-	LPS 40/75	0.75	1	-	IE3	-	-	80.9	82.3	82.1	-	0.91	-	3.0	1.7	-	19.7	11.4
LPS 50/40M	LPS 50/40	0.4	0.5	-	-	12.5	450	-	-	-	0.62	0.61	2.74	2.2	1.25	9.8	11.0	6.5
LPS 50/75M	LPS 50/75	0.75	1	-	IE2	25	450	77.2	80.9	81.3	1.08	0.92	4.9	3.0	1.7	20.3	22.0	12.9
-	LPS 50/75	0.75	1	-	IE3	-	-	80.9	82.3	82.1	-	0.91	-	3.0	1.7	-	19.7	11.4
LPS 50/150M	LPS 50/150	1.5	2	-	IE2	40	450	78.6	83.0	84.2	1.82	1.78	8.07	6.3	3.7	43.0	34.3	20.0
-	LPS 50/150	1.5	2	-	IE3	-	-	82.7	86.1	87.0	-	1.72	-	6.6	3.8	-	66.6	38.4

NOISE DATA

Pump type		Power		L _{pA} - dB(A) *
Single Phase	Three Phase	[kW]	[HP]	
LPS 25/08M	LPS 25/08	0,08	0,1	60
LPS 25/15M	LPS 25/15	0,15	0,2	
LPS 25/25M	LPS 25/25	0,25	0,33	
LPS 32/25M	LPS 32/25	0,25	0,33	61
LPS 32/40M	LPS 32/40	0,4	0,5	
LPS 40/25M	LPS 40/25	0,25	0,33	
LPS 40/40M	LPS 40/40	0,4	0,5	
LPS 40/75M	LPS 40/75	0,75	1	62
LPS 50/40M	LPS 50/40	0,4	0,5	
LPS 50/75M	LPS 50/75	0,75	1	63
LPS 50/150M	LPS 50/150	1,5	2	65

* Mean value of several measures at 1m distance around the pump.
Tolerance ± 2.5 dB.

INSTALLATION

