



POMPE ROTOMECC

KB 100/6-220.1

DN 100

Giri/1' - r.p.m. 960

Elettropompe centrifughe ad asse orizzontale con girante bicanale aperta e diffusore autopulente
Centrifugal horizontal pumps with channel impeller and cutting diffuser
Pompes à axe horizontal avec roue à canaux et anneau tranchant

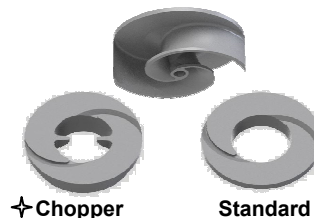
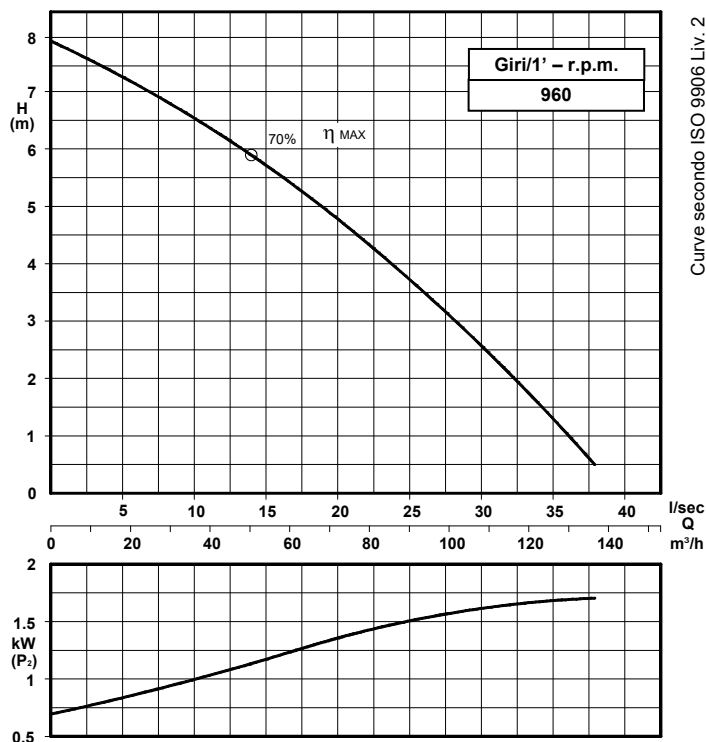

Grandezza - Size - Group 100/220

curva Curve Courbe N°	Pompa Pump Pompe	DN	Potenza motore Motor power P2 (Kw)	Giri/1' r.p.m.
1	KB 100/6-219 A2 S1	100	3	960

P2 - Potenza resa - Shaft power - Puissance sur arbre

COSTRUZIONE - Materials - Matériaux	
Fusioni principali - Principal parts - Parts principal	Ghisa - Cast iron - Fonte - GG 25
Girante - Impeller - Roue	Ghisa - Cast iron - Fonte - GS 500
Albero - Shaft - Arbre	AISI 420
Viteria - Screws - Vis	AISI 304

TENUTE MECCANICHE - Mechanical seals - Garniture mécanique
Doppia tenuta meccanica in bagno d'olio - Double mechanical seals in oil bath - Double garniture mécanique en chambre d'huile
Tenuta lato motore / tenuta lato liquido : carburo di silicio Motor side / liquid side mechanical seal : silicon carbide Garniture mécanique côté du moteur / côté liquide : carbure de silicium

CARATTERISTICHE TECNICHE - Technical Features - Caractéristiques Techniques
Max. temperatura liquido - Max. liquid temp. - Max. temperature du liquide : 60°C
pH Liquido pompato - pH pumped liquid - pH du liquide pompé : 6 - 10

✦ Versione chopper con diffusore a taglienti e girante induriti
Chopper version with cutting diffuser and impeller hardened
Version chopper avec anneau tranchant et roue durci

DIMENSIONI DI INGOMBRO – Dimensions

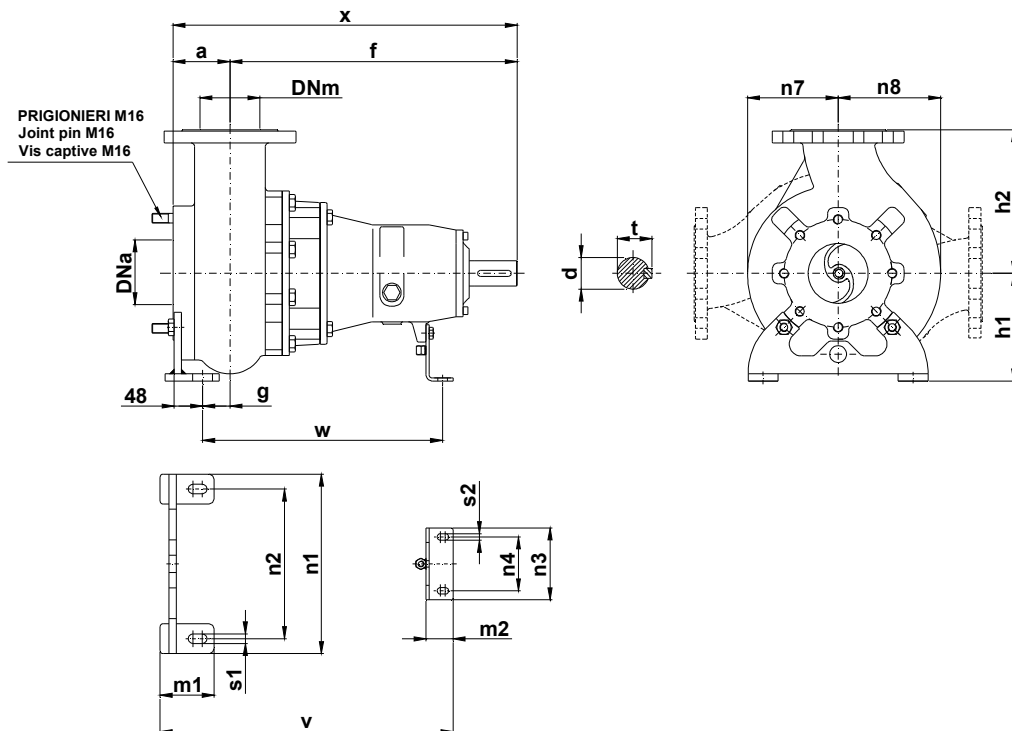

Pompa Pump Pompe	DNa DNm	a	b	c	d	e	f	g	h1	h2	m1	m2	n1	n2	n3	n4	n7	n8	s1	s2	t	u	v	w	x	Peso Weight Poids
KB 100 / .. A2S1	100	95	50	12	42	80	550	46	180	240	90	45	300	250	120	90	155	175	16	11	45	12	547	458	635	90

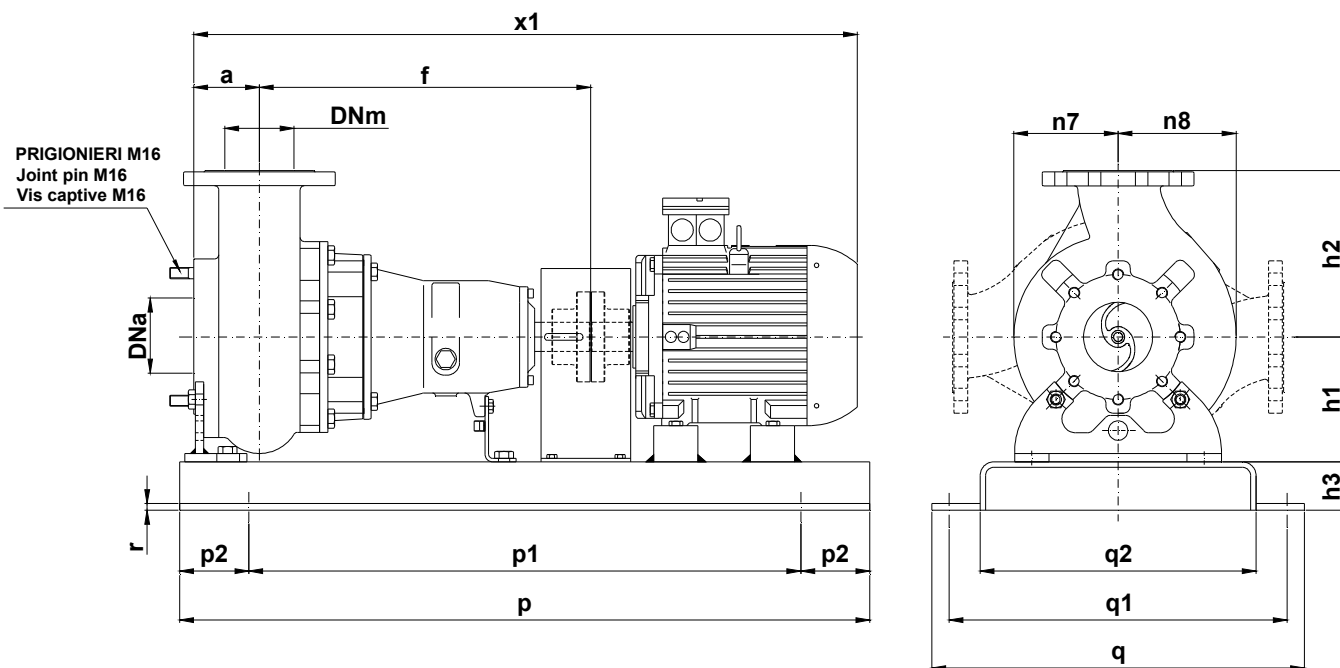

Pompa Pump Pompe	kW	Giri/1' r.p.m.	Motore Motor - Moteur MEC	h3	p	p1	p2	q	q1	q2	r	r1	x1	Peso Weight Poids
KB 100/6-219 A2 S1	3	960	132	90	1200	1000	800	560	510	440	12	18	1080	235

KB 100/6-220.1.17W

Con riserva di variazioni tecniche e costruttive senza preavviso.
With reserve of technical and constructive variations without warning. – Avec réserve de variations techniques et constructives sans préavis.

POMPE ROTOMECC srl - 20063 CERNUSCO SUL NAVIGLIO (MI) - ITALY - Via Ponchielli,1

☎ 02 92110205 - 02 92330399 📠 02 92110630 🌐 Sito Internet: www.pomperotomec.it ✉ E-mail: sales@pomperotomec.it



POMPE ROTOMEK

Elettropompe centrifughe ad asse orizzontale con girante arretrata a vortice
Centrifugal horizontal pumps with vortex impeller
Pompes à axe horizontal avec roue vortex

KB 100/6-280.1

DN 100

Giri/1' - r.p.m.
960



UNI EN ISO 9001 - 2015

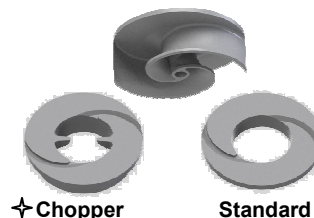
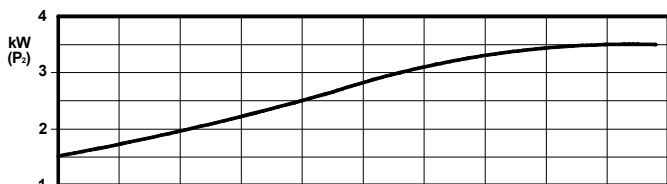
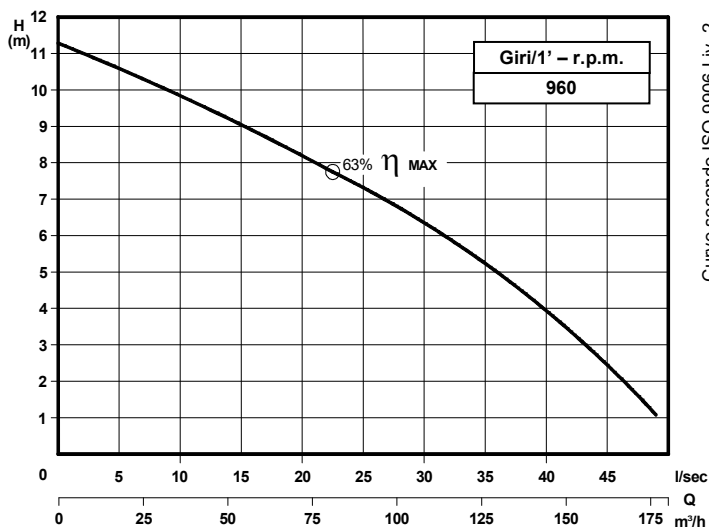

Grandezza - Size - Group 100/280

Curva Curve Courbe N°	Pompa Pump Pompe	DN	Potenza motore Motor power Puissance du moteur P2 (Kw)	Giri/1' r.p.m.
1	KB 100/6-260 A3 S2	100	4	960

P2 - Potenza resa - Shaft power - Puissance sur arbre

COSTRUZIONE - Materials - Matériaux	
Fusioni principali - Principal parts - Parts principal	Ghisa - Cast iron - Fonte - GG 25
Girante - Impeller - Roue	Ghisa - Cast iron - Fonte - GS 500
Albero - Shaft - Arbre	AISI 420
Viteria - Screws - Vis	AISI 304

TENUTE MECCANICHE - Mechanical seals - Garniture mécanique
Doppia tenuta meccanica in bagno d'olio - Double mechanical seals in oil bath - Double garniture mécanique en chambre d'huile
Tenuta lato motore / tenuta lato liquido : carburo di silicio Motor side / liquid side mechanical seal : silicon carbide Garniture mécanique côté du moteur / côté liquide : carbure de silicium

CARATTERISTICHE TECNICHE - Technical Features - Caractéristiques Techniques
Max. temperatura liquido - Max. liquid temp. - Max. temperature du liquide : 60°C
pH Liquido pompato - pH pumped liquid - pH du liquide pompé : 6 - 10

Versione chopper con diffusore a taglienti e girante induriti
Chopper version with cutting diffuser and impeller hardened
Version chopper avec anneau tranchant et roue durci

DIMENSIONI DI INGOMBRO – Dimensions

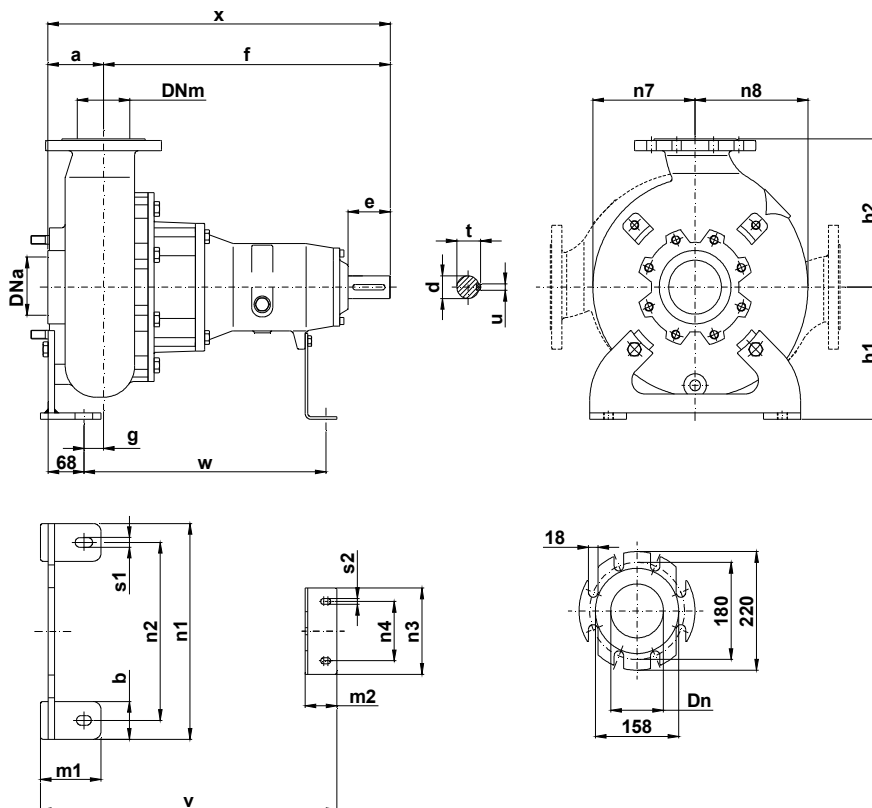

Pompa Pump Pompe	DNa DNm	a	b	d	e	f	g	h1	h2	m1	m2	n1	n2	n3	n4	n7	n8	s1	s2	t	u	v	w	x	Peso Weight Poids
KB 100 / .. A3S2	100	105	70	42	80	545	38	245	275	115	60	400	330	160	110	195	215	18	11	45	12	565	460	650	100

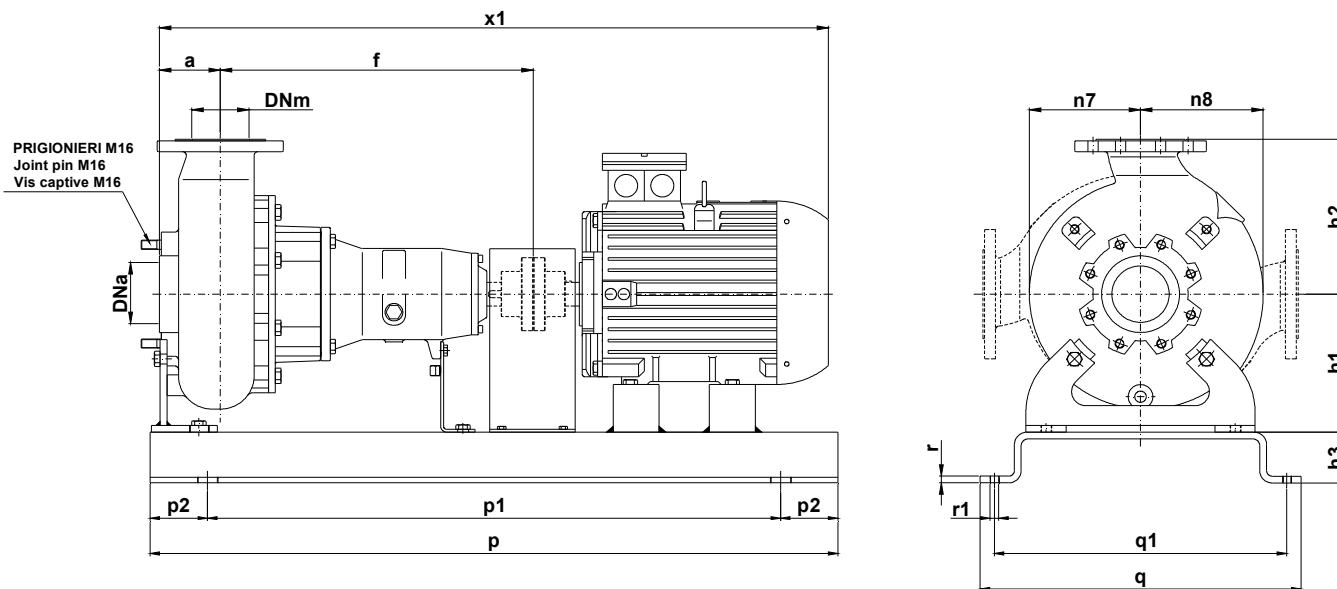

Pompa Pump Pompe	kW	Giri/1' r.p.m.	Motore Motor - Moteur MEC	h3	p	p1	p2	q	q1	q2	r	r1	x1	Peso Weight Poids
KB 100/6-260 A3 S2	4	960	132	90	1200	1000	100	560	510	440	12	18	1080	275

KB 100/6-280.1.17

Con riserva di variazioni tecniche e costruttive senza preavviso.
With reserve of technical and constructive variations without warning. – Avec réserve de variations techniques et constructives sans préavis.

POMPE ROTOMECH srl - 20063 CERNUSCO SUL NAVIGLIO (MI) - ITALY - Via Ponchielli,1

☎ 02 92110205 - 02 92330399 📠 02 92110630 **Sito Internet:** www.pomperotomec.it **E-mail:** sales@pomperotomec.it



POMPE ROTOMEC

KB 100/4-220.1

DN 100

Giri/1' - r.p.m.

1450

Elettropompe centrifughe ad asse orizzontale con girante bicanale aperta e diffusore autopulente
Centrifugal horizontal pumps with channel impeller and self cleaning diffuser
Pompes à axe horizontal avec roue à canaux et anneau autonettoyant



UNI EN ISO 9001 - 2015

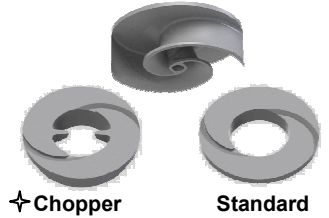
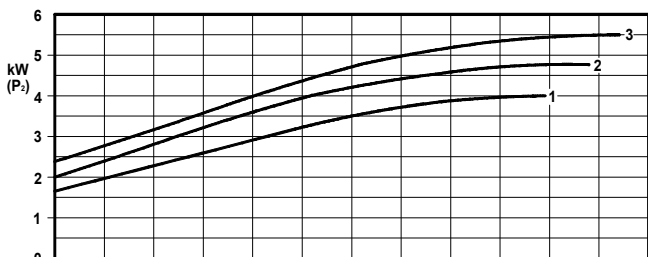
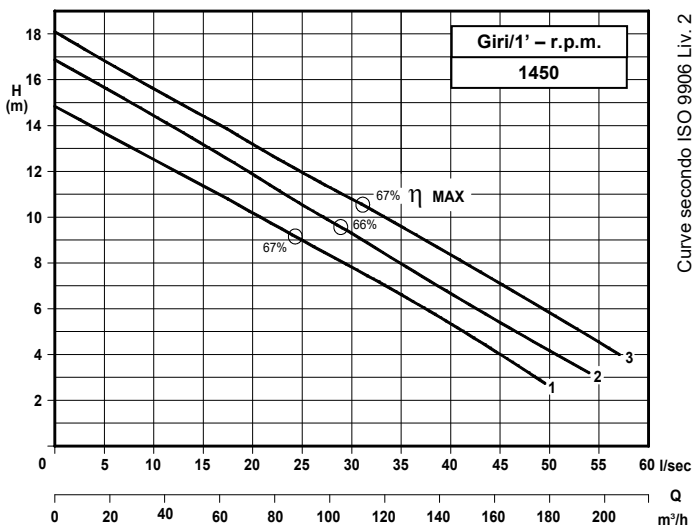
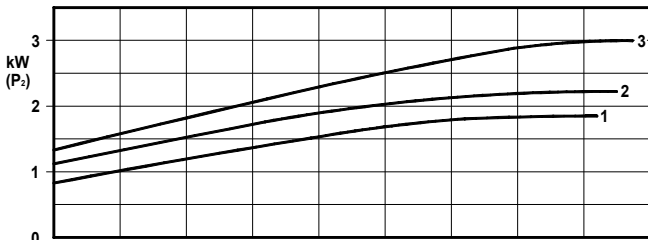
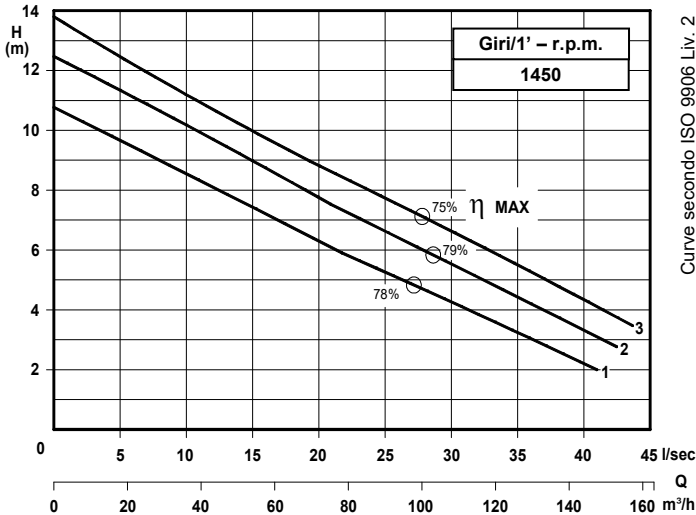

Grandezza - Size - Group 100/220

curva Curve Courbe N°	Pompa Pump Pompe	DN	Potenza motore Motor power P2 (Kw)	Giri/1' r.p.m.
1	KB 100-175 A1 S1	100	2,2	1450
2	KB 100-185 A1 S1			
3	KB 100-195 A1 S1		3	

P2 - Potenza resa - Shaft power - Puissance sur arbre

COSTRUZIONE - Materials - Matériaux	
Fusioni principali - Principal parts - Parts principal	Ghisa - Cast iron - Fonte - GG 25
Girante - Impeller - Roue	Ghisa - Cast iron - Fonte - GS 500
Albero - Shaft - Arbre	AISI 420
Viteria - Screws - Vis	AISI 304

TENUTE MECCANICHE - Mechanical seals - Garniture mécanique
Doppia tenuta meccanica in bagno d'olio - Double mechanical seals in oil bath - Double garniture mécanique en chambre d'huile
Tenuta lato motore / tenuta lato liquido : carburo di silicio
Motor side / liquid side mechanical seal : silicon carbide
Garniture mécanique côté du moteur / côté liquide : carbure de silicium

CARATTERISTICHE TECNICHE - Technical Features - Caractéristiques Techniques
Max. temperatura liquido - Max. liquid temp. - Max. temperature du liquide : 60°C
pH Liquido pompato - pH pumped liquid - pH du liquide pompé : 6 - 10

Grandezza - Size - Group 100/220

curva Curve Courbe N°	Pompa Pump Pompe	DN	Potenza motore Motor power P2 (Kw)	Giri/1' r.p.m.
1	KB 100-202 A2 S1	100	4	1450
2	KB 100-215 A2 S1		5,5	
3	KB 100-219 A2 S1			

P2 - Potenza resa - Shaft power - Puissance sur arbre

✦ Versione chopper con diffusore a taglienti e girante induriti
Chopper version with cutting diffuser and impeller hardened
Version chopper avec anneau tranchant et roue durci

DIMENSIONI DI INGOMBRO – Dimensions

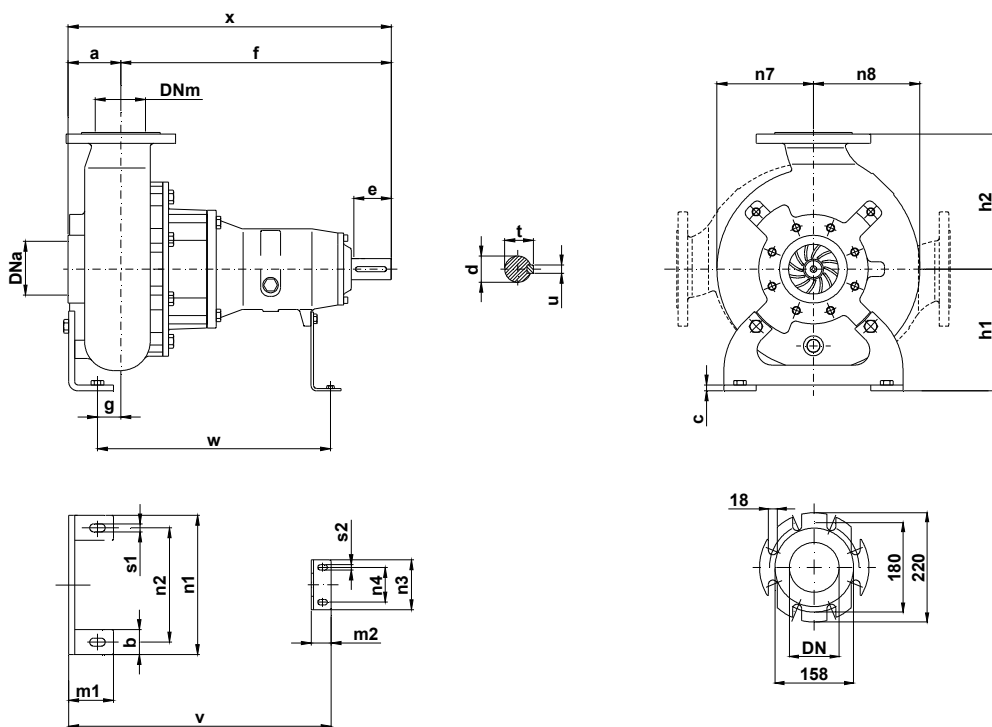

Pompa Pump Pompe	DNa DNm	a	b	c	d	e	f	g	h1	h2	m1	m2	n1	n2	n3	n4	n7	n8	s1	s2	t	u	v	w	x	Peso Weight Poids
KB 100 / .. A1S1 KB 100 / .. A2S1	100	95	50	12	32	80	480	49	180	240	75	45	300	250	120	90	155	175	16	11	35	10	466	402	575	75

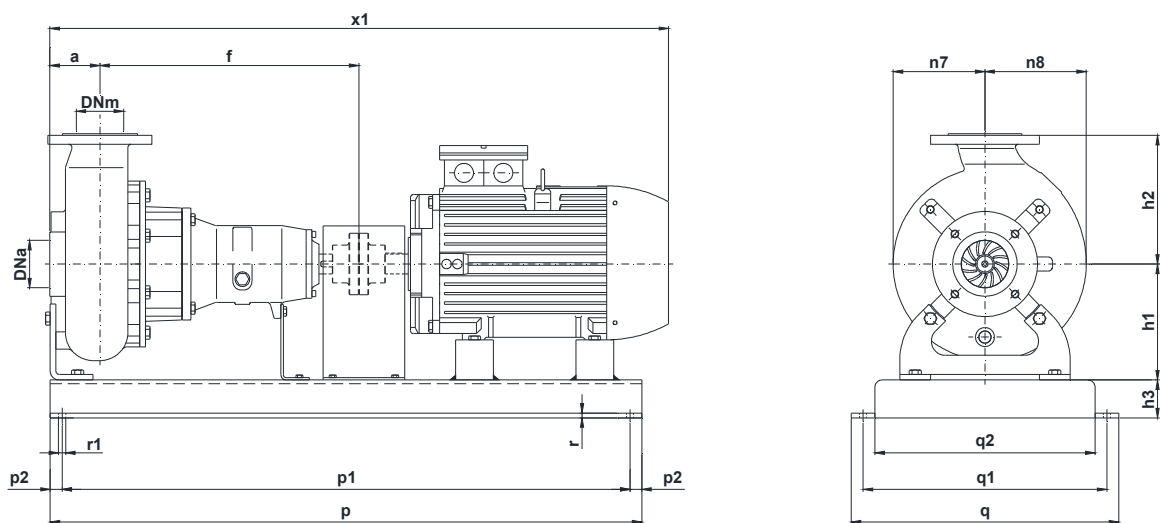

Pompa Pump Pompe	kW	Giri/1' r.p.m.	Motore Motor - Moteur MEC	h3	p	p1	p2	q	q1	q2	r	r1	x1	Peso Weight Poids
KB 100-175 A1 S1	2,2	1450	100	70	1000	800	100	500	420	360	10	16	965	141
KB 100-185 A1 S1														143
KB 100-195 A1 S1														153
KB 100-202 A1 S1	3													
KB 100-215 A2 S1	4													
KB 100-219 A2 S1	5,5		132	90	1200	1000	800	560	510	440	12	18	1095	226

KB 100/4-220.1.17W

Con riserva di variazioni tecniche e costruttive senza preavviso.
With reserve of technical and constructive variations without warning. – Avec réserve de variations techniques et constructives sans préavis.

POMPE ROTOMECC srl - 20063 CERNUSCO SUL NAVIGLIO (MI) - ITALY - Via Ponchielli,1

☎ 02 92110205 - 02 92330399 📠 02 92110630 **Sito Internet:** www.pomperotomec.it **E-mail:** sales@pomperotomec.it



POMPE ROTOMECC

KB 100/4-280.1

DN 100

Giri/1' - r.p.m.
1450

Elettropompe centrifughe ad asse orizzontale con girante bicanale aperta e diffusore autopulente
Centrifugal horizontal pumps with channel impeller and self cleaning diffuser
Pompes à axe horizontal avec roue à canaux et anneau autonettoyant

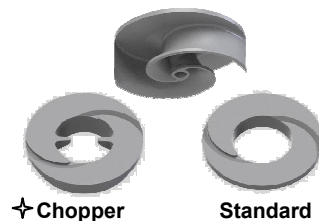
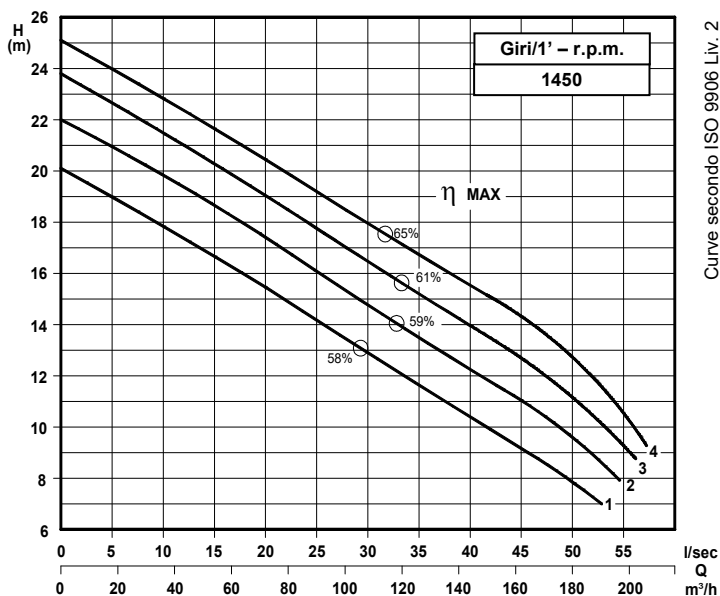

Grandezza - Size - Group 100/280

curva Curve Courbe N°	Pompa Pump Pompe	DN	Potenza motore Motor power P2 (Kw)	Giri/1' r.p.m.
1	KB 100-228 A3 S2	100	7,5	1450
2	KB 100-240 A3 S2			
3	KB 100-250 A3 S2		11	
4	KB 100-255 A3 S2			

P2 - Potenza resa - Shaft power - Puissance sur arbre

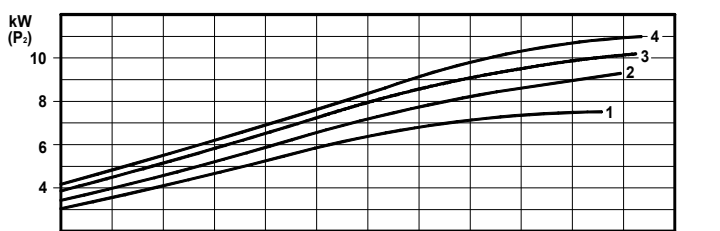

COSTRUZIONE - Materials - Matériaux	
Fusioni principali - Principal parts - Parts principal	Ghisa - Cast iron - Fonte - GG 25
Girante - Impeller - Roue	Ghisa - Cast iron - Fonte - GS 500
Albero - Shaft - Arbre	AISI 420
Viteria - Screws - Vis	AISI 304

TENUTE MECCANICHE - Mechanical seals - Garniture mécanique	
Doppia tenuta meccanica in bagno d'olio - Double mechanical seals in oil bath - Double garniture mécanique en chambre d'huile	
Tenuta lato motore / tenuta lato liquido : carburo di silicio Motor side / liquid side mechanical seal : silicon carbide	
Garniture mécanique côté du moteur / côté liquide : carbure de silicium	

CARATTERISTICHE TECNICHE - Technical Features - Caractéristiques Techniques	
Max. temperatura liquido - Max. liquid temp. - Max. temperature du liquide : 60°C	
pH Liquido pompato - pH pumped liquid - pH du liquide pompé : 6 - 10	

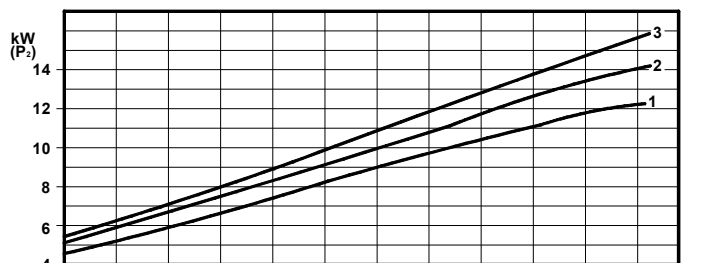
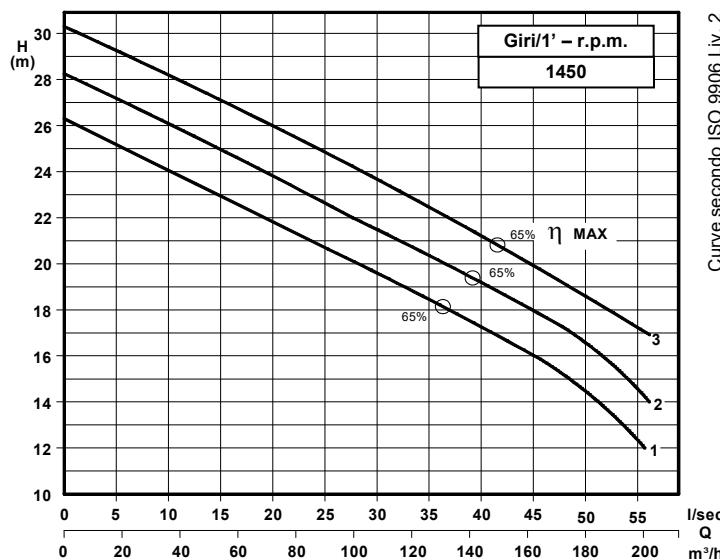

Grandezza - Size - Group 100/280

curva Curve Courbe N°	Pompa Pump Pompe	DN	Potenza motore Motor power P2 (Kw)	Giri/1' r.p.m.
1	KB 100-260 A3 S2	100	15	1450
2	KB 100-270 A3 S2			
3	KB 100-279 A3 S2		18,5	

P2 - Potenza resa - Shaft power - Puissance sur arbre

Versione chopper con diffusore a taglienti e girante induriti
Chopper version with cutting diffuser and impeller hardened
Version chopper avec anneau tranchant et roue durci

DIMENSIONI DI INGOMBRO – Dimensions

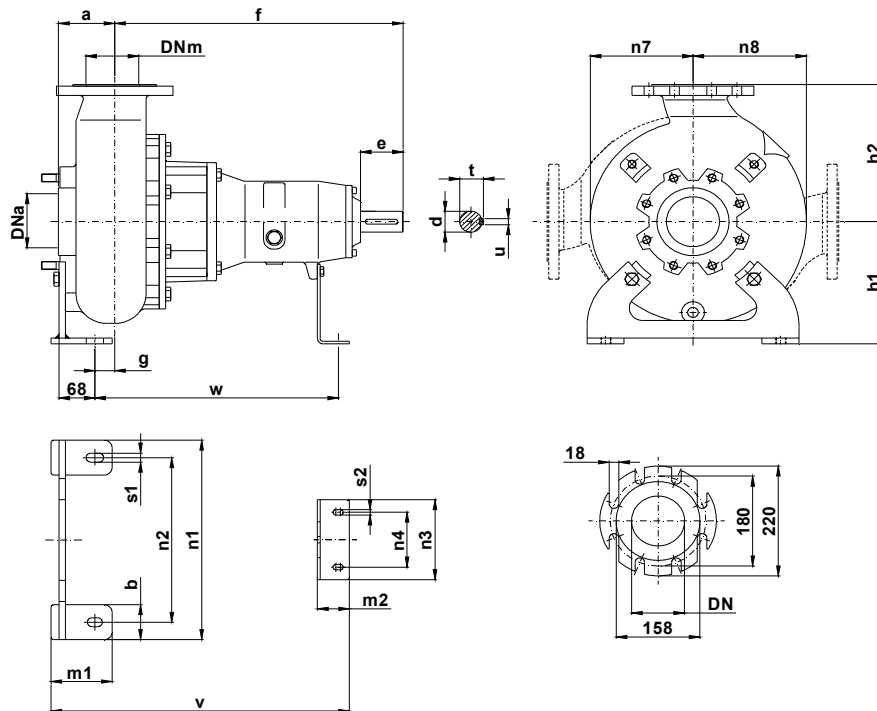

Pompa Pump Pompe	DNa DNm	a	b	c	d	e	f	g	h1	h2	m1	m2	n1	n2	n3	n4	n7	n8	s1	s2	t	u	v	w	x	Peso Weight Poids
KB 100 / .. A3S2	100	105	70	12	42	80	545	48	245	275	100	60	400	330	160	110	195	215	18	11	45	12	548	470	650	100

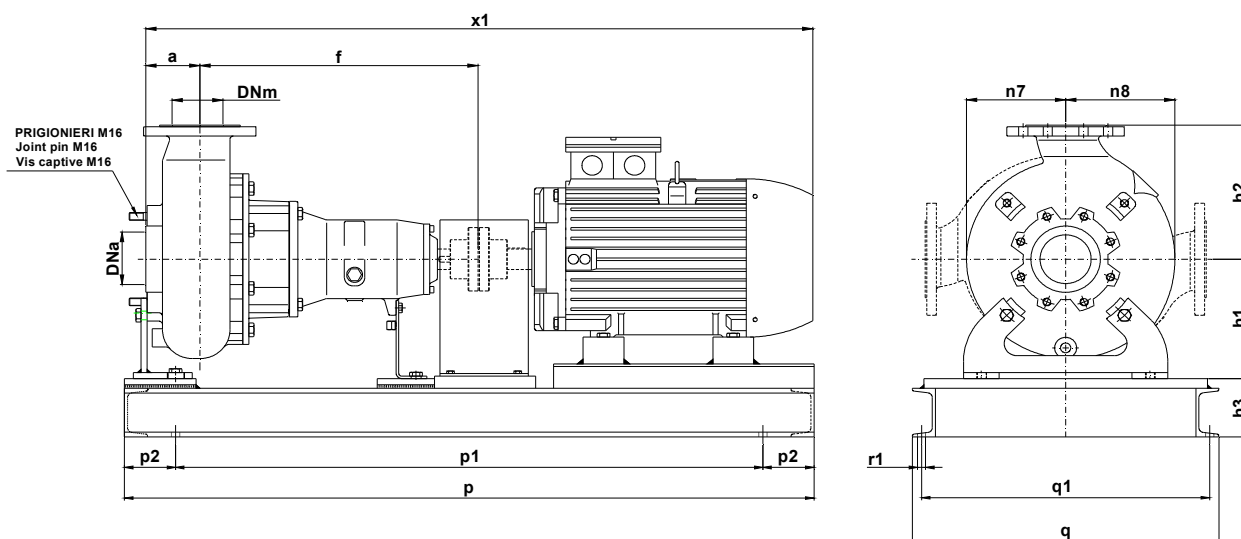

Pompa Pump Pompe	kW	Giri/1' r.p.m.	Motore Motor - Moteur MEC	h3	p	p1	p2	q	q1	r1	x1	Peso Weight Poids
KB 100-228 A3 S2	7,5	1450	132	90	1200	1000		560	510	16	1165	275
KB 100-240 A3 S2	11		160	120	1350	1150	100	600	564	18	1260	334
KB 100-250 A3 S2												
KB 100-255 A3 S2	15		160	120	1350	1150	100	600	564	18	1260	334
KB 100-260 A3 S2												
KB 100-270 A3 S2	18,5		160	120	1350	1150	100	600	564	18	1260	334
KB 100-279 A3 S2												

KB 100/4-280.1.17W

Con riserva di variazioni tecniche e costruttive senza preavviso.
With reserve of technical and constructive variations without warning. – Avec réserve de variations techniques et constructives sans préavis.

POMPE ROTOMECC srl - 20063 CERNUSCO SUL NAVIGLIO (MI) - ITALY - Via Ponchielli,1

☎ 02 92110205 - 02 92330399 📠 02 92110630 🌐 Sito Internet: www.pomperotomec.it ✉ E-mail: sales@pomperotomec.it



POMPE ROTOMECH

KB 100/4-375.1

DN 100

Giri/1' - r.p.m. 1450

Elettropompe centrifughe ad asse orizzontale con girante bicanale aperta e diffusore autopulente
Centrifugal horizontal pumps with channel impeller and self-cleaning diffuser
Pompes à axe horizontal avec roue à canaux et anneau autonettoyant

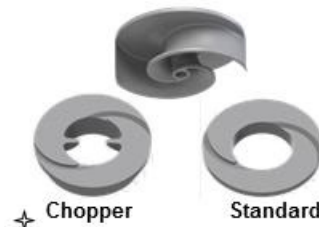
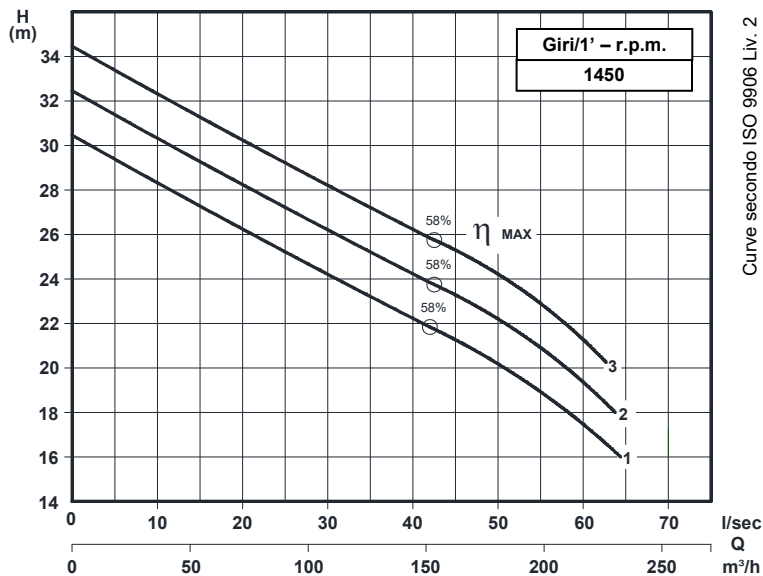

Grandezza - Size - Group 100/375

Curva Curve Courbe N°	Pompa Pump Pompe	DN	Potenza motore Motor power P2 (Kw)	Giri/1' r.p.m.
1	KB 100 - 290 A4 S3	100	22	1450
2	KB 100 - 300 A4 S3			
3	KB 100 - 310 A4 S3			

P2 - Potenza resa - Shaft power - Puissance sur arbre

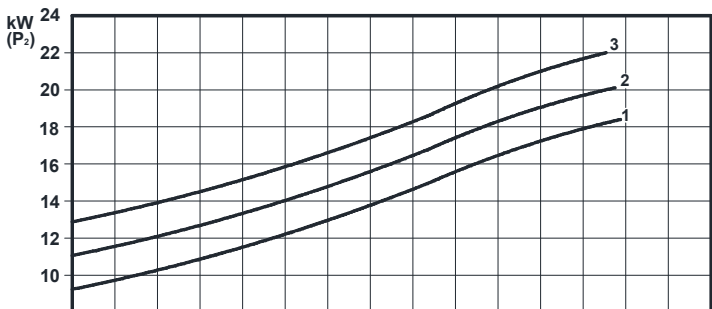

COSTRUZIONE - Materials - Matériaux

Fusioni principali - Principal parts - Parts principal	Ghisa - Cast iron - Fonte - GG 25
Girante - Impeller - Roue	Ghisa - Cast iron - Fonte - GS 500
Albero - Shaft - Arbre	AISI 420
Viteria - Screws - Vis	AISI 304

TENUTE MECCANICHE - Mechanical seals - Garniture mécanique

Doppia tenuta meccanica in bagno d'olio - Double mechanical seals in oil bath - Double garniture mécanique en chambre d'huile

Tenuta lato motore / tenuta lato liquido : carburo di silicio

Motor side / liquid side mechanical seal : silicon carbide

Garniture mécanique côté du moteur / côté liquide : carbure de silicium

CARATTERISTICHE TECNICHE - Technical Features - Caractéristiques Techniques

Max. temperatura liquido - Max. liquid temp. - Max. temperature du liquide : 60°C

pH Liquido pompato - pH pumped liquid - pH du liquide pompé : 6 - 10

✦ Versione chopper con diffusore a taglienti e girante induriti
Chopper version with cutting diffuser and impeller hardened
Version chopper avec anneau tranchant et roue durci

DIMENSIONI DI INGOMBRO – Dimensions

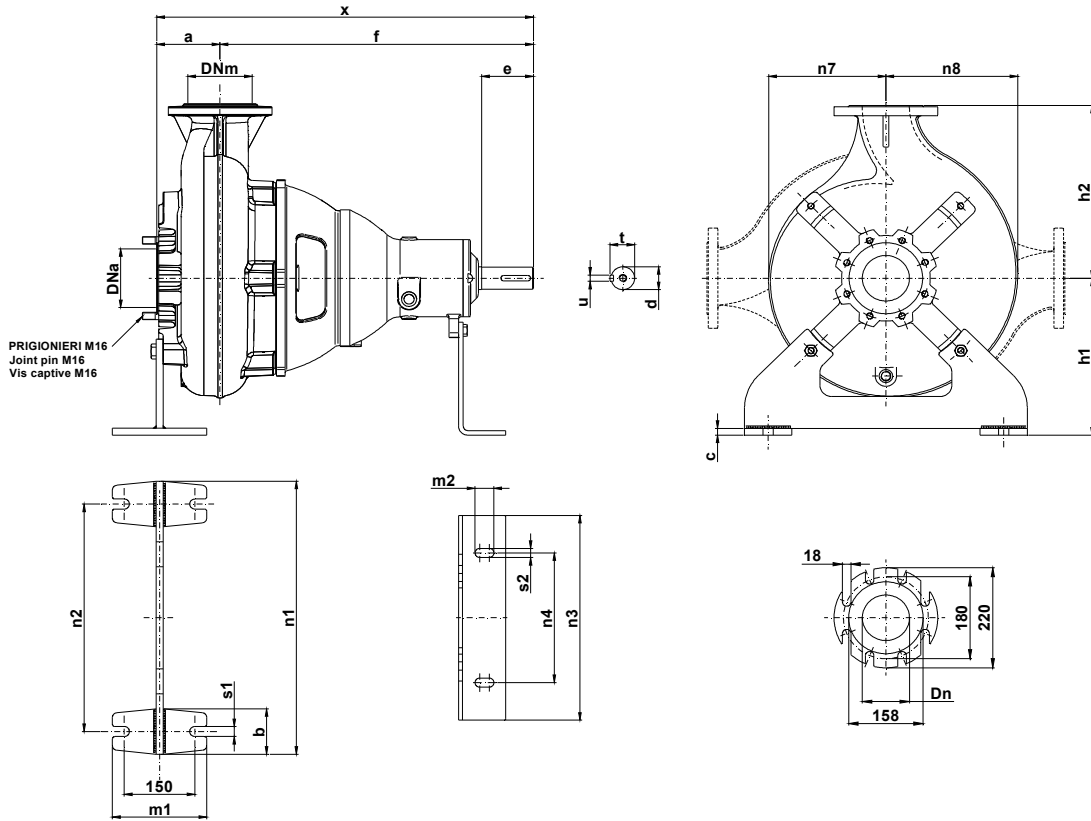

Pompa Pump Pompe	DNa DNm	a	b	c	d	e	f	g	h1	h2	m1	m2	n1	n2	n3	n4	n7	n8	s1	s2	t	u	v	w	x	Peso Weight Poids
KB 100 / .. A4S3	100	135	100	12	42	110	665	53	345	400	200	100	400	330	150	110	210	240	22	20	53	14	860	641	827	203

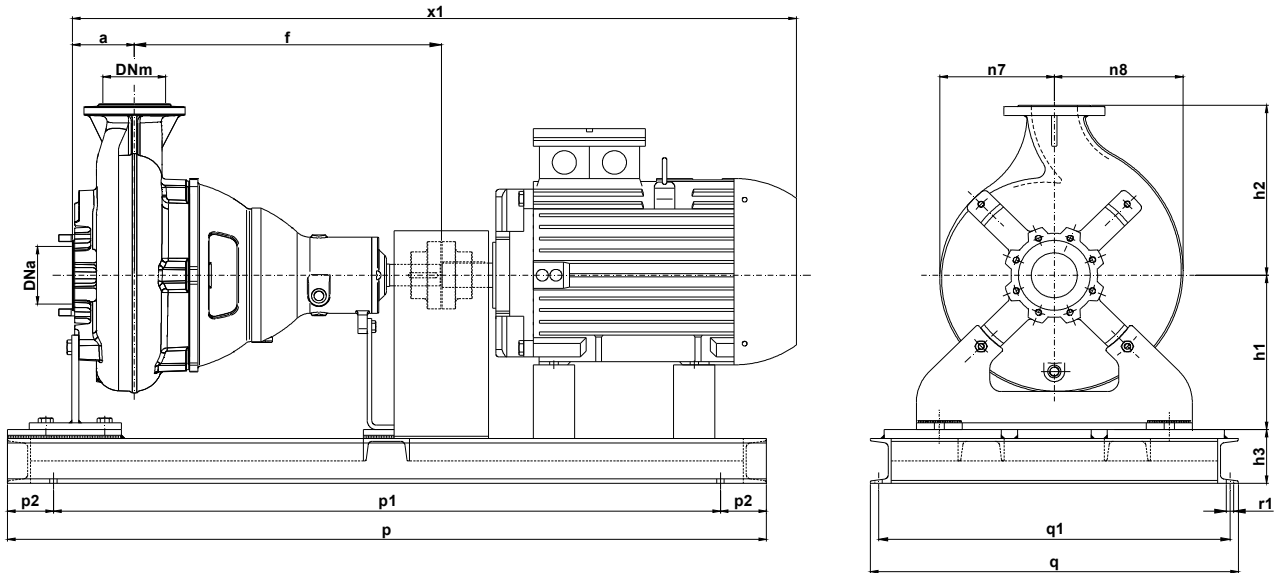

Pompa Pump Pompe	kW	Giri/1' r.p.m.	Motore Motor - Moteur MEC	h3	p	p1	p2	q	q1	x1	Peso Weight Poids
KB 100 - 290 A4 S3	22	1450	180	120	1650	1450	100	800	765	1520	490
KB 100 - 300 A4 S3											
KB 100 - 310 A4 S3											

KB 100-375.1.17

Con riserva di variazioni tecniche e costruttive senza preavviso.
With reserve of technical and constructive variations without warning. – Avec réserve de variations techniques et constructives sans préavis.

POMPE ROTOMECC srl - 20063 CERNUSCO SUL NAVIGLIO (MI) - ITALY - Via Ponchielli,1

☎ 02 92110205 - 02 92330399 📠 02 92110630 🌐 Sito Internet: www.pomperotomec.it ✉ E-mail: sales@pomperotomec.it



POMPE ROTOMECC

KB 100/4-375.2

DN 100

Giri/1' - r.p.m. 1450

Elettropompe centrifughe ad asse orizzontale con girante bicanale aperta e diffusore autopulente
Centrifugal horizontal pumps with channel impeller and self-cleaning diffuser
Pompes à axe horizontal avec roue à canaux et anneau autonettoyant

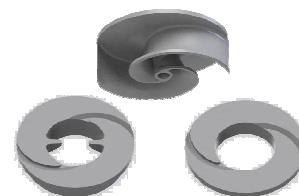
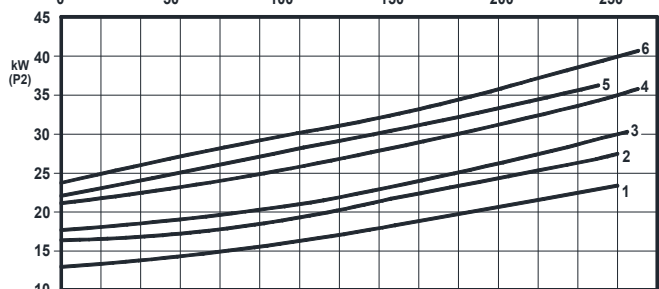
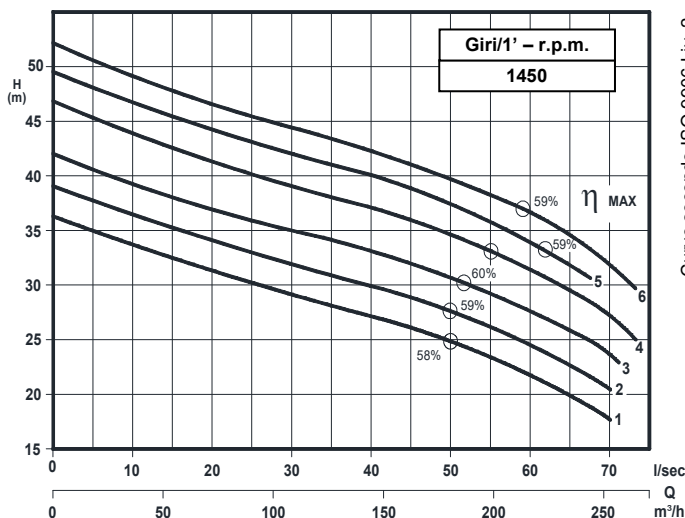

✦ Chopper

Standard

Grandezza - Size - Group 100/375

Curva Curve Courbe N°	Pompa Pump Pompe	DN	Potenza motore Motor power P2 (Kw)	Giri/1' r.p.m.	Passaggio libero Free passage Section de passage
1	KB 100 - 318 A4 S3	100	30	1450	-
2	KB 100 - 327 A4 S3				
3	KB 100 - 340 A4 S3				
4	KB 100 - 353 A4 S3		37		
5	KB 100 - 363 A4 S3				
6	KB 100 - 373 A4 S3				

P2 - Potenza resa - Shaft power - Puissance sur arbre

COSTRUZIONE - Materials - Matériaux

Fusioni principali - Principal parts - Parts principal	Ghisa - Cast iron - Fonte - GG 25
Girante - Impeller - Roue	Ghisa - Cast iron - Fonte - GS 500
Albero - Shaft - Arbre	AISI 420
Viteria - Screws - Vis	AISI 304

TENUTE MECCANICHE - Mechanical seals - Garniture mécanique

Doppia tenuta meccanica in bagno d'olio - Double mechanical seals in oil bath - Double garniture mécanique en chambre d'huile

Tenuta lato motore / tenuta lato liquido : carburo di silicio

Motor side / liquid side mechanical seal : silicon carbide

Garniture mécanique côté du moteur / côté liquide : carbure de silicium

CARATTERISTICHE TECNICHE - Technical Features - Caractéristiques Techniques

Max. temperatura liquido - Max. liquid temp. - Max. temperature du liquide : 60°C

pH Liquido pompato - pH pumped liquid - pH du liquide pompé : 6 - 10

✦ Versione chopper con diffusore a taglienti e girante induriti
Chopper version with cutting diffuser and impeller hardened
Version chopper avec anneau tranchant et roue durci

DIMENSIONI DI INGOMBRO – Dimensions

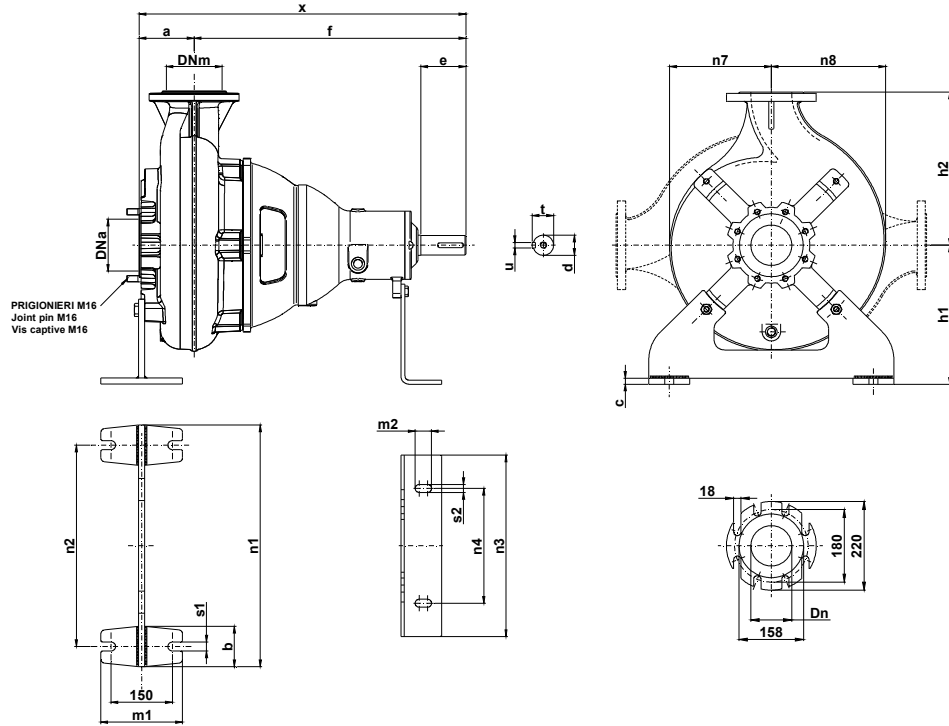

Pompa Pump Pompe	DNa DNm	a	b	c	d	e	f	g	h1	h2	m1	m2	n1	n2	n3	n4	n7	n8	s1	s2	t	u	v	w	x	Peso Weight Poids
KB 100 / .. A4S3	100	135	100	12	42	110	665	53	345	400	200	100	400	330	150	110	210	240	22	20	53	14	860	641	827	203

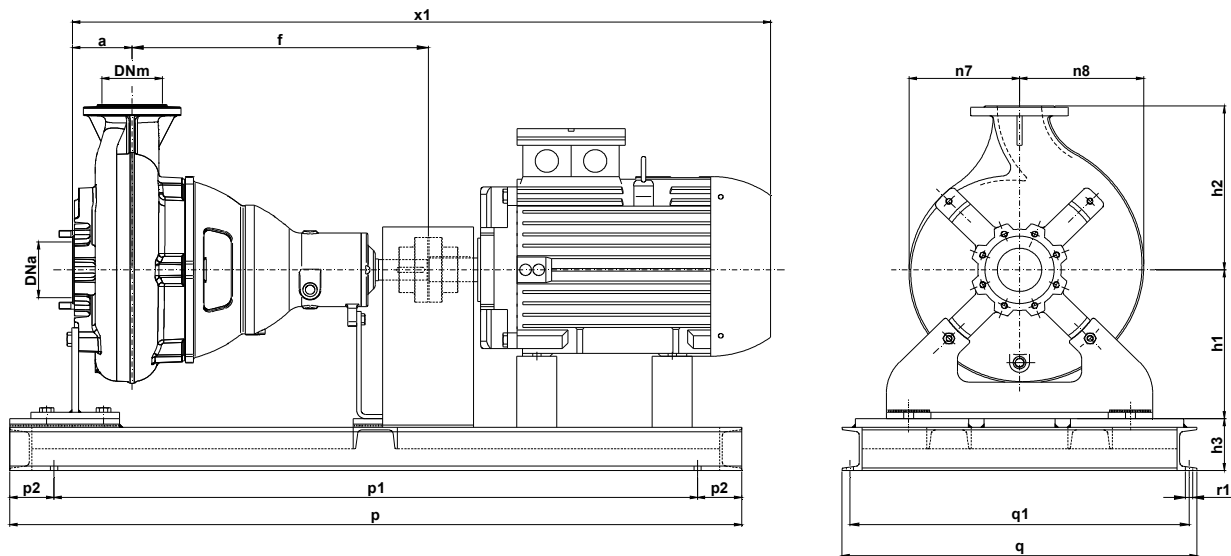

Pompa Pump Pompe	kW	Giri/1' r.p.m.	Motore Motor - Moteur MEC	h3	p	p1	p2	q	q1	x1	Peso Weight Poids
KB 100 - 318 A4 S3	30	1450	200	120	1650	1450	100	800	765	1573	540
KB 100 - 327 A4 S3											
KB 100 - 340 A4 S3	37	225	225	120	1650	1450	100	800	765	1625	595
KB 100 - 353 A4 S3											
KB 100 - 363 A4 S3											
KB 100 - 373 A4 S3	45									1650	628

KB 100-375.2.17

Con riserva di variazioni tecniche e costruttive senza preavviso.
With reserve of technical and constructive variations without warning. – Avec réserve de variations techniques et constructives sans préavis.

POMPE ROTOMECC srl - 20063 CERNUSCO SUL NAVIGLIO (MI) - ITALY - Via Ponchielli,1

☎ 02 92110205 - 02 92330399 📠 02 92110630 🌐 Sito Internet: www.pomperotomec.it ✉ E-mail: sales@pomperotomec.it



POMPE ROTOMECH

KB 100/2-220.1

DN 100

Giri/1' - r.p.m.
2900

Elettropompe centrifughe ad asse orizzontale con girante bicanale aperta e diffusore autopulente
Centrifugal horizontal pumps with channel impeller and self cleaning diffuser
Pompes à axe horizontal avec roue à canaux et anneau autonettoyant

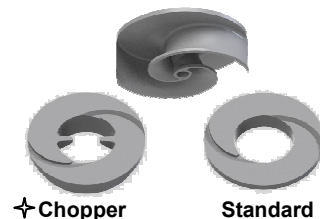
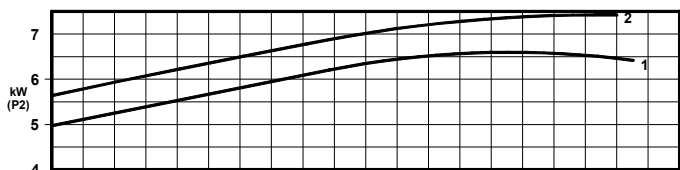
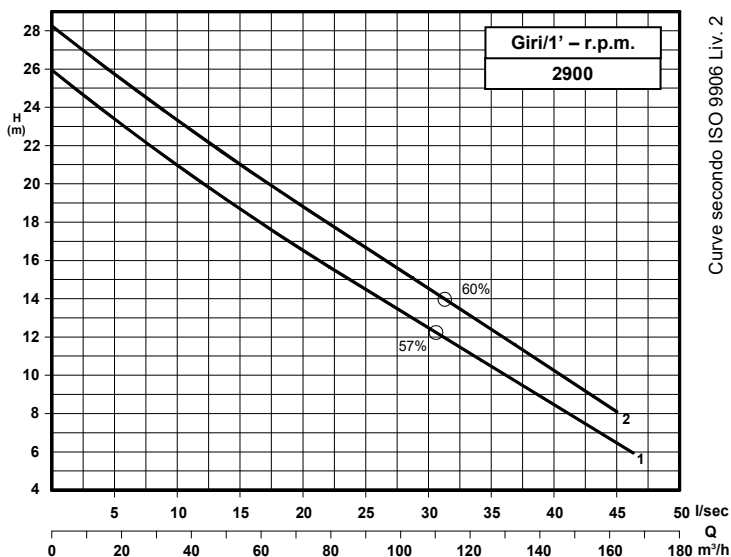

Grandezza - Size - Group 100/220

curva Curve Courbe N°	Pompa Pump Pompe	DN	Potenza motore Motor power P2 (Kw)	Giri/1' r.p.m.
1	KB 100/2-150 A3 S2	100	7,5	2900
2	KB 100/2-156 A3 S2			

P2 - Potenza resa - Shaft power - Puissance sur arbre

COSTRUZIONE - Materials - Matériaux

Fusioni principali - Principal parts - Parts principal	Ghisa - Cast iron - Fonte - GG 25
Girante - Impeller - Roue	Ghisa - Cast iron - Fonte - GS 500
Albero - Shaft - Arbre	AISI 420
Viteria - Screws - Vis	AISI 304

TENUTE MECCANICHE - Mechanical seals - Garniture mécanique

Doppia tenuta meccanica in bagno d'olio - Double mechanical seals in oil bath - Double garniture mécanique en chambre d'huile

Tenuta lato motore / tenuta lato liquido : carburo di silicio

Motor side / liquid side mechanical seal : silicon carbide

Garniture mécanique côté du moteur / côté liquide : carbure de silicium

CARATTERISTICHE TECNICHE - Technical Features - Caractéristiques Techniques

Max. temperatura liquido - Max. liquid temp. - Max. temperature du liquide : 60°C

pH Liquido pompato - pH pumped liquid - pH du liquide pompé : 6 - 10

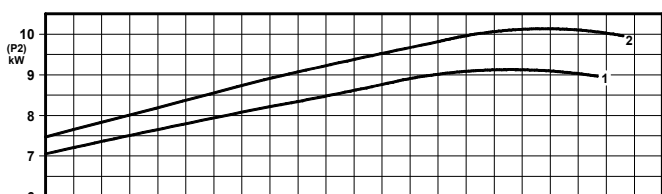
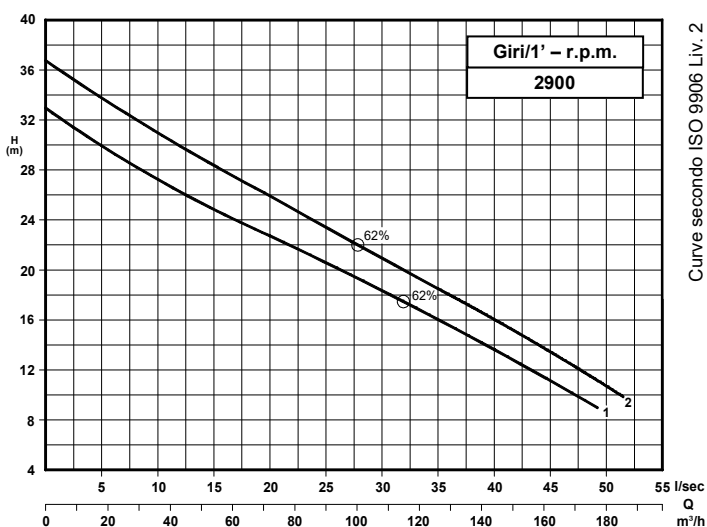

Grandezza - Size - Group 100/220

curva Curve Courbe N°	Pompa Pump Pompe	DN	Potenza motore Motor power P2 (Kw)	Giri/1' r.p.m.
1	KB 100/2-164 A3 S2	100	11	2900
2	KB 100/2-170 A3 S2			

P2 - Potenza resa - Shaft power - Puissance sur arbre

✦ Versione chopper con diffusore a taglienti e girante induriti
Chopper version with cutting diffuser and impeller hardened
Version chopper avec anneau tranchant et roue durci

DIMENSIONI DI INGOMBRO – Dimensions

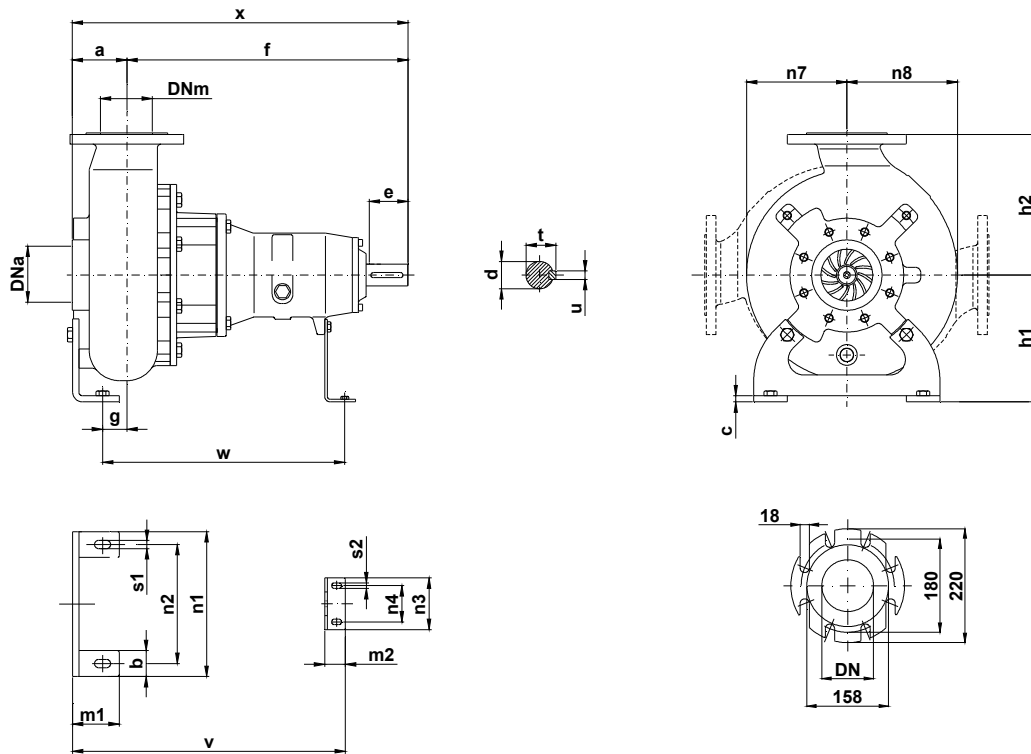

Pompa Pump Pompe	DNa DNm	a	b	c	d	e	f	g	h1	h2	m1	m2	n1	n2	n3	n4	n7	n8	s1	s2	t	u	v	w	x	Peso Weight Poids
KB 100 / .. A3S2	100	105	70	12	42	80	545	48	245	275	100	60	400	330	160	110	195	215	18	11	45	12	548	470	650	100

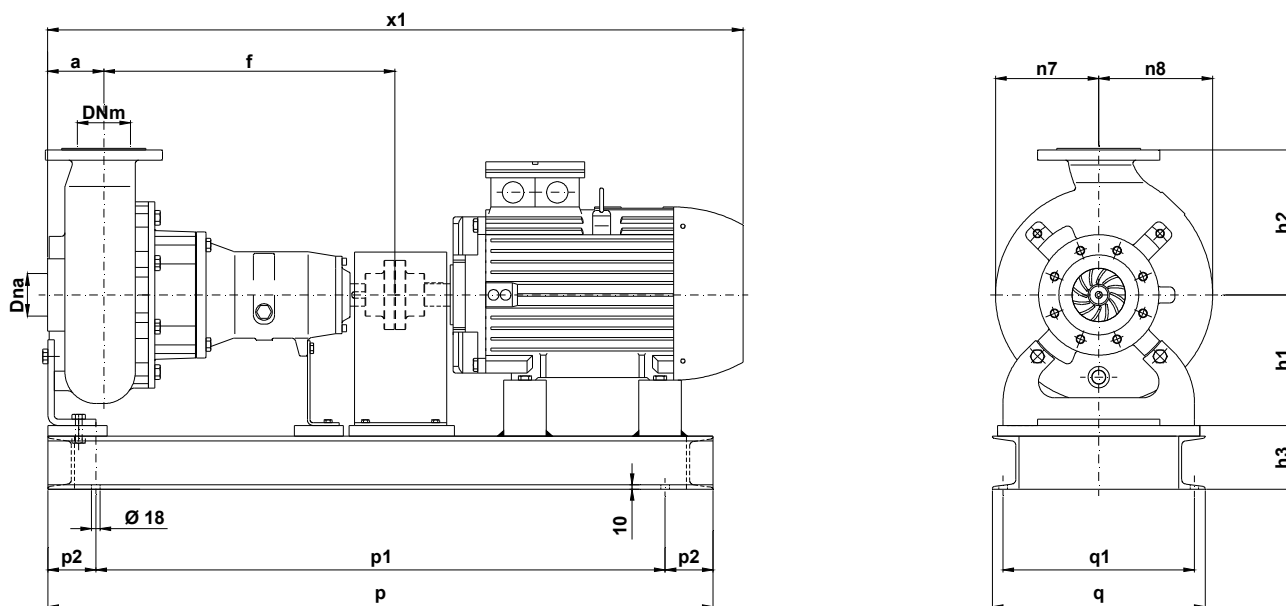

Pompa Pump Pompe	kW	Giri/1' r.p.m.	Motore Motor - Moteur MEC	h3	p	p1	p2	q	q1	x1	Peso Weight Poids
KB 100/2-150 A3 S2	7,5	2900	132	90	1200	1100	100	560	510	1145	270
KB 100/2-156 A3 S2											
KB 100/2-164 A3 S2	11	2900	160*	120	1350	1150	100	600	564	1240	324
KB 100/2-170 A3 S2											

KB 100/2-220.2.17W

*Basamento in acciaio profilato saldato – *Profiled welded steel base* – *Profilé de base en acier soudé*

Con riserva di variazioni tecniche e costruttive senza preavviso.
 With reserve of technical and constructive variations without warning. – Avec réserve de variations techniques et constructives sans préavis.

POMPE ROTOMECC srl - 20063 CERNUSCO SUL NAVIGLIO (MI) - ITALY - Via Ponchielli,1

☎ 02 92110205 - 02 92330399 📠 02 92110630 **Sito Internet:** www.pomperotomec.it **E-mail:** sales@pomperotomec.it



POMPE ROTOMECH

KB 100/2-220.2

DN 100

Giri/1' - r.p.m. 2900

Elettropompe centrifughe ad asse orizzontale con girante bicanale aperta e diffusore autopulente
Centrifugal horizontal pumps with channel impeller and self cleaning diffuser
Pompes à axe horizontal avec roue à canaux et anneau autonettoyant



UNI EN ISO 9001 - 2015

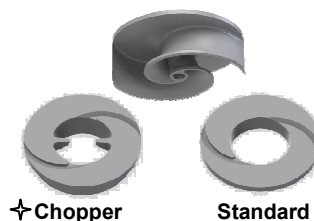
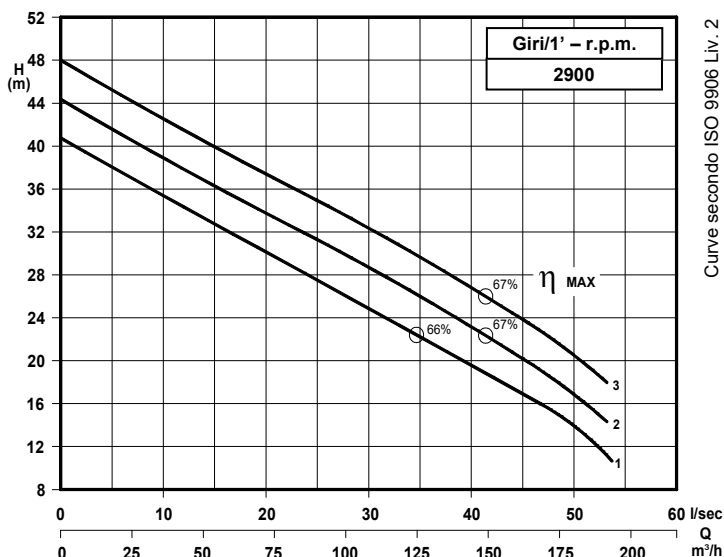

Grandezza - Size - Group 100/220

curva Curve Courbe N°	Pompa Pump Pompe	DN	Potenza motore Motor power P2 (Kw)	Giri/1' r.p.m.
1	KB 100/2-178 A3 S2	100	15	2900
2	KB 100/2-186 A3 S2			
3	KB 100/2-192 A3 S2			

P2 - Potenza resa - Shaft power - Puissance sur arbre

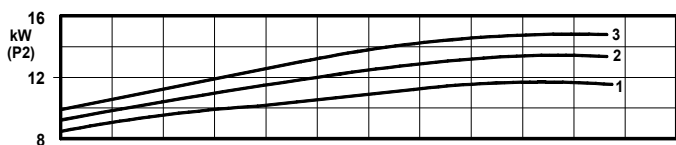

COSTRUZIONE - Materials - Matériaux	
Fusioni principali - Principal parts - Parts principal	Ghisa - Cast iron - Fonte - GG 25
Girante - Impeller - Roue	Ghisa - Cast iron - Fonte - GS 500
Albero - Shaft - Arbre	AISI 420
Viteria - Screws - Vis	AISI 304

TENUTE MECCANICHE - Mechanical seals - Garniture mécanique
Doppia tenuta meccanica in bagno d'olio - Double mechanical seals in oil bath - Double garniture mécanique en chambre d'huile
Tenuta lato motore / tenuta lato liquido : carburo di silicio
Motor side / liquid side mechanical seal : silicon carbide
Garniture mécanique côté du moteur / côté liquide : carbure de silicium

CARATTERISTICHE TECNICHE - Technical Features - Caractéristiques Techniques
Max. temperatura liquido - Max. liquid temp. - Max. temperature du liquide : 60°C
pH Liquido pompato - pH pumped liquid - pH du liquide pompé : 6 - 10

✦ Versione chopper con diffusore a taglienti e girante induriti
Chopper version with cutting diffuser and impeller hardened
Version chopper avec anneau tranchant et roue durci

DIMENSIONI DI INGOMBRO – Dimensions

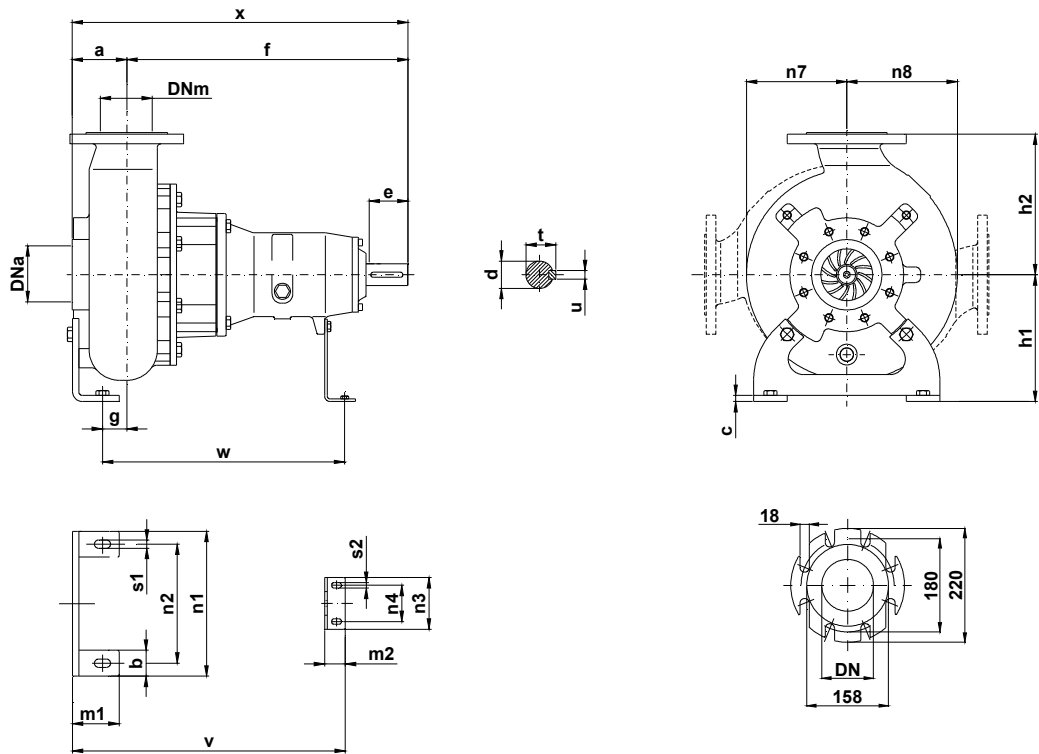

Pompa Pump Pompe	DNa DNm	a	b	c	d	e	f	g	h1	h2	m1	m2	n1	n2	n3	n4	n7	n8	s1	s2	t	u	v	w	x	Peso Weight Poids
KB 100 / .. A3S2	100	105	70	12	42	80	550	46	180	240	90	45	300	250	120	90	155	175	16	11	45	12	547	458	635	90

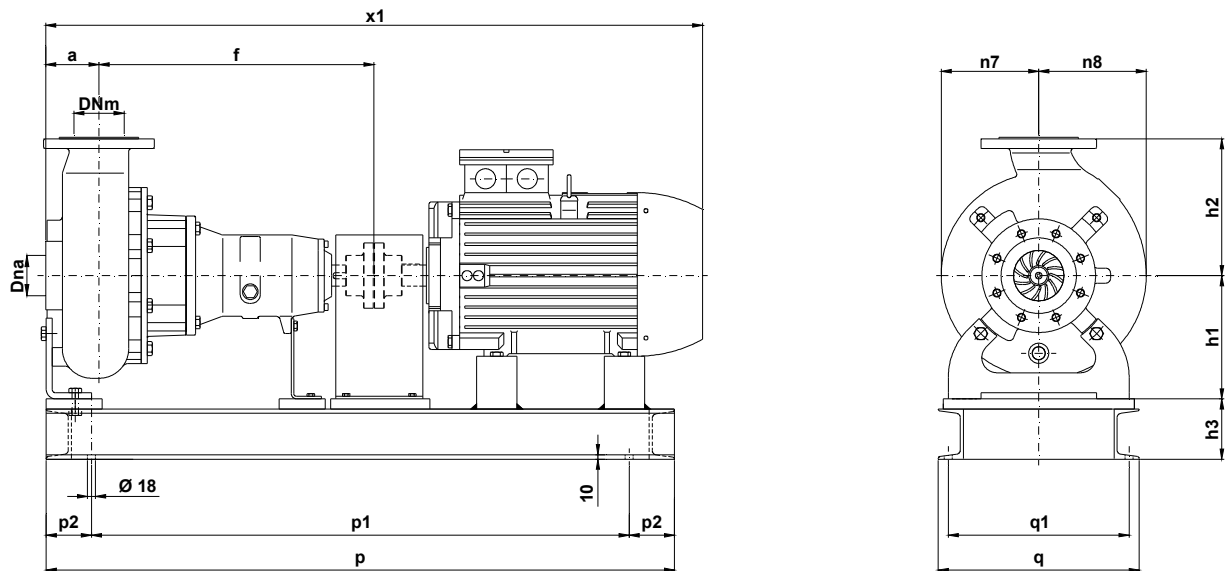

Pompa Pump Pompe	kW	Giri/1' r.p.m.	Motore Motor – Moteur MEC	h3	p	p1	p2	q	q1	r1	x1	Peso Weight Poids
KB 100/2-178 A3 S2	15	2900	160	90	1350	1150	100	600	564	18	1291	315
KB 100/2-186 A3 S2												
KB 100/2-192 A3 S2												

KB 100/2-220.4.17W

Con riserva di variazioni tecniche e costruttive senza preavviso.
With reserve of technical and constructive variations without warning. – Avec réserve de variations techniques et constructives sans préavis.

POMPE ROTOMECC srl - 20063 CERNUSCO SUL NAVIGLIO (MI) - ITALY - Via Ponchielli,1

☎ 02 92110205 - 02 92330399 📠 02 92110630 🌐 Sito Internet: www.pomperotomec.it ✉ E-mail: sales@pomperotomec.it



POMPE ROTOMECC

KB 100/2-280.1

DN 100

Giri/1' - r.p.m.
2900

Elettropompe centrifughe ad asse orizzontale con girante bicanale aperta e diffusore autopulente
 Centrifugal horizontal pumps with channel impeller and self cleaning diffuser
 Pompes à axe horizontal avec roue à canaux et anneau autonettoyant

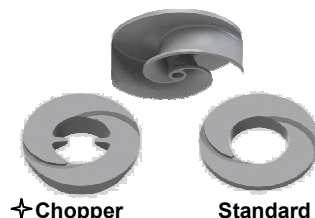
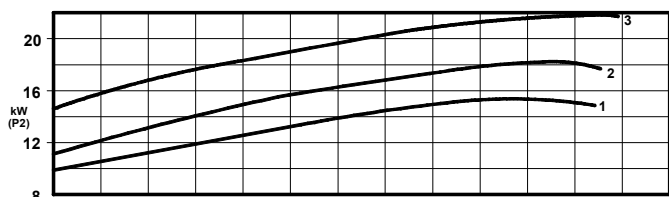
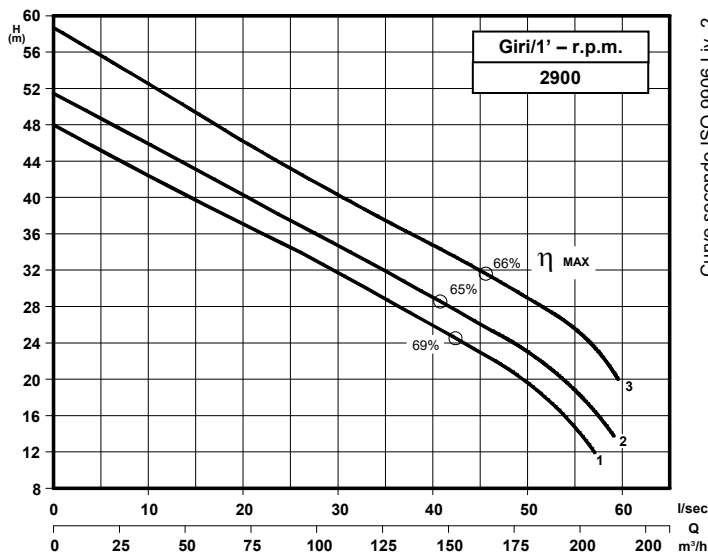

Grandezza - Size - Group 100/280

curva Curve Courbe N°	Pompa Pump Pompe	DN	Potenza motore Motor power P2 (Kw)	Giri/1' r.p.m.
1	KB 100/2-192 A3 S2	100	18,5	2900
2	KB 100/2-200 A3 S2		22	
3	KB 100/2-203 A3 S2			

P2 - Potenza resa - Shaft power - Puissance sur arbre

COSTRUZIONE - Materials - Matériaux	
Fusioni principali - Principal parts - Parts principal	Ghisa - Cast iron - Fonte - GG 25
Girante - Impeller - Roue	Ghisa - Cast iron - Fonte - GS 500
Albero - Shaft - Arbre	AISI 420
Viteria - Screws - Vis	AISI 304

TENUTE MECCANICHE - Mechanical seals - Garniture mécanique
Doppia tenuta meccanica in bagno d'olio - Double mechanical seals in oil bath - Double garniture mécanique en chambre d'huile
Tenuta lato motore / tenuta lato liquido : carburo di silicio
Motor side / liquid side mechanical seal : silicon carbide
Garniture mécanique côté du moteur / côté liquide : carbure de silicium

CARATTERISTICHE TECNICHE - Technical Features - Caractéristiques Techniques
Max. temperatura liquido - Max. liquid temp. - Max. temperature du liquide : 60°C
pH Liquido pompato - pH pumped liquid - pH du liquide pompé : 6 - 10

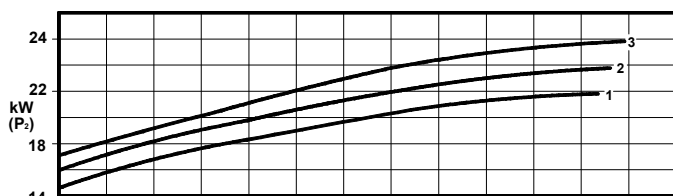
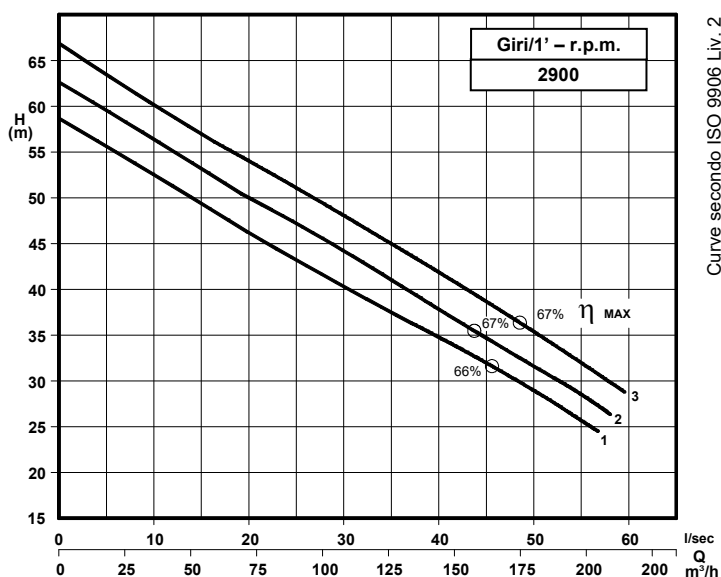

Grandezza - Size - Group 100/280

curva Curve Courbe N°	Pompa Pump Pompe	DN	Potenza motore Motor power P2 (Kw)	Giri/1' r.p.m.
1	KB 100/2-206 A3 S2	100	30	2900
2	KB 100/2-213 A3 S2			
3	KB 100/2-219 A3 S2			

P2 - Potenza resa - Shaft power - Puissance sur arbre

✦ Versione chopper con diffusore a taglienti e girante induriti
 Chopper version with cutting diffuser and impeller hardened
 Version chopper avec anneau tranchant et roue durci

DIMENSIONI DI INGOMBRO – Dimensions

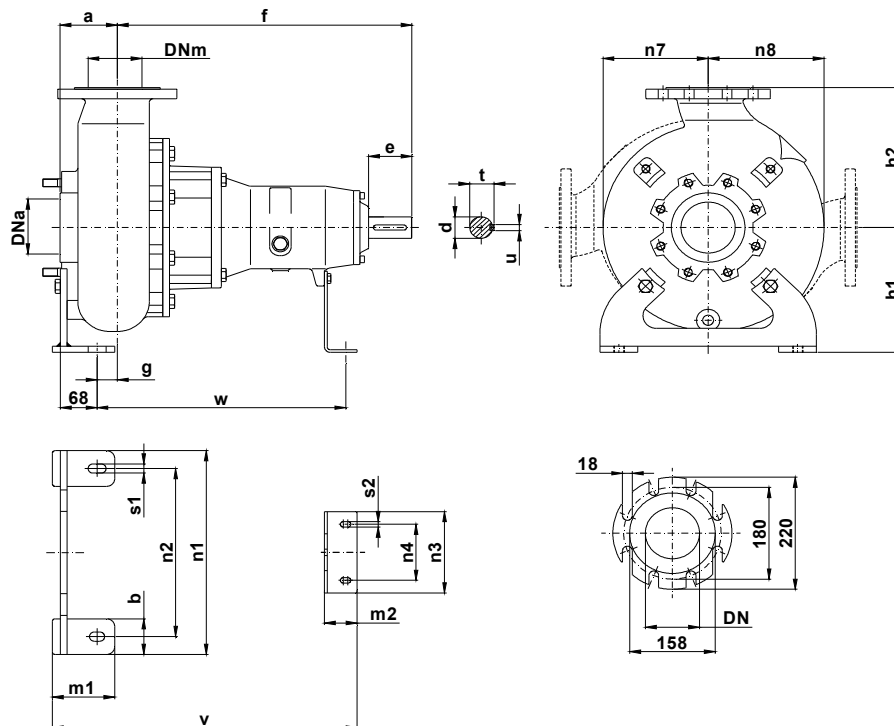

Pompa Pump Pompe	DNa DNm	a	b	c	d	e	f	g	h1	h2	m1	m2	n1	n2	n3	n4	n7	n8	s1	s2	t	u	v	w	x	Peso Weight Poids
KB 100 / .. A3S2	100	105	70	12	42	80	545	48	245	275	100	60	400	330	160	110	195	215	18	11	45	12	548	470	650	100

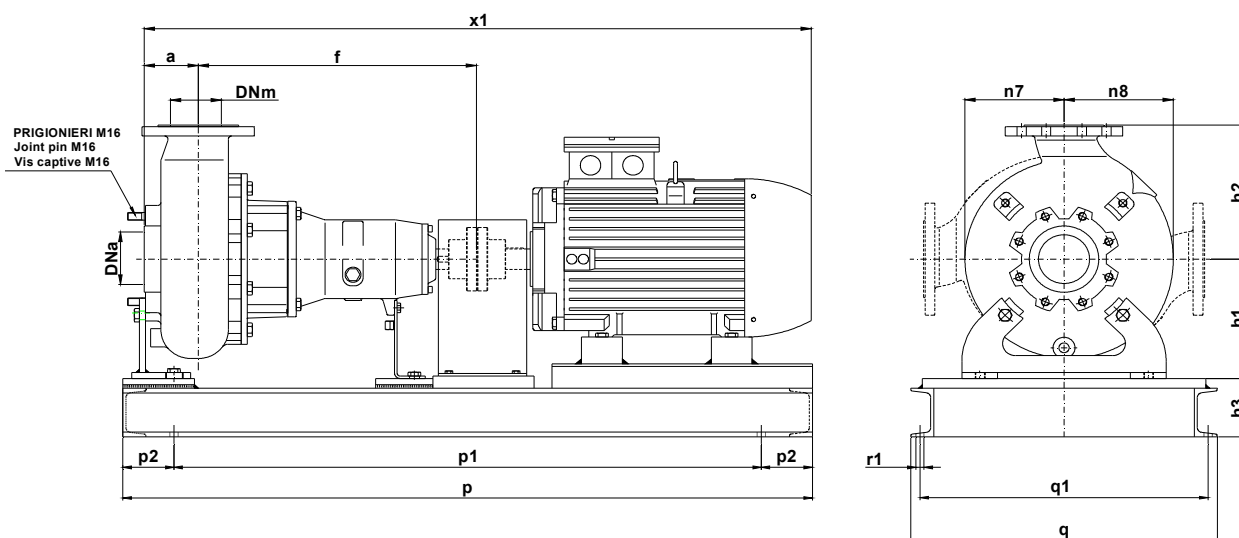

Pompa Pump Pompe	kW	Giri/1' r.p.m.	Motore Motor - Moteur MEC	h3	p	p1	p2	q	q1	x1	Peso Weight Poids									
KB 100/2-192 A3 S2	18,5	2900	160	120	1350	1150	100	600	564	1305	368									
KB 100/2-200 A3 S2	22		180							1335	400									
KB 100/2-203 A3 S2			200							1370	475									
KB 100/2-206 A3 S2	30	2900	200	120	1350	1150	100	600	564	1370	475									
KB 100/2-213 A3 S2										30	2900	200	120	1350	1150	100	600	564	1370	475
KB 100/2-219 A3 S2																			1370	475

KB 100/2-280.1.17W

Con riserva di variazioni tecniche e costruttive senza preavviso.
With reserve of technical and constructive variations without warning. – Avec réserve de variations techniques et constructives sans préavis.

POMPE ROTOMECC srl - 20063 CERNUSCO SUL NAVIGLIO (MI) - ITALY - Via Ponchielli,1

☎ 02 92110205 - 02 92330399 📠 02 92110630 🌐 Sito Internet: www.pomperotomec.it ✉ E-mail: sales@pomperotomec.it