

AJ300G418R370RA

SOTR

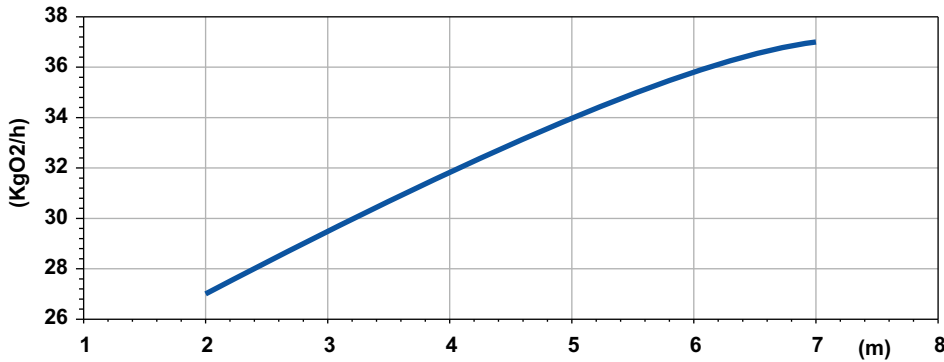

Potenza Assorbita - Absorbed Power P1
 Puissance Absorbée - Leistungsaufnahme P1
 Potencia Absorbida - Поглощенная мощность P1

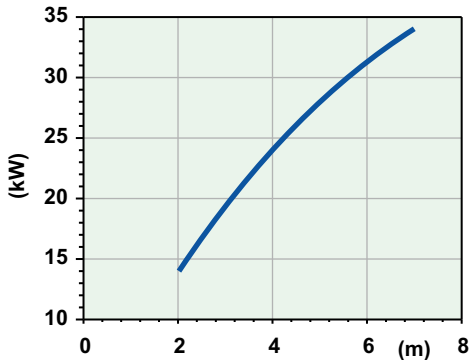

Aria Aspirata - Suction Air
 L'air D'aspiration - Saugluft
 Succión De Aire - Аспирированный воздух
 Nm³ a 0 °C, RH 0 %, p = 101,3 kPa

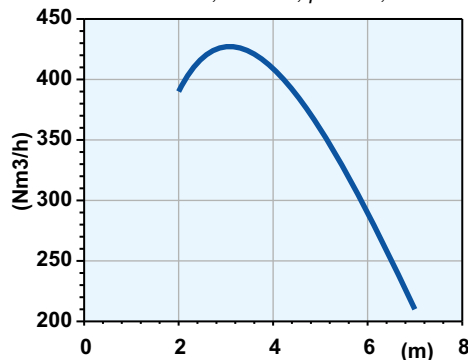

Battente idraulico - Hydraulic head - Charge hydraulique - Hydraulischen Belastung
 Cabezal hidráulico - Гидронапор

Code	5009659
Type	AJ300G418R370RA
Suction (mm)	DN125
Free passage (mm)	30x50
Immersion depth (m)	2-7
Motor type	M418T-35,7-400/50YY-IE3
Power supply	3ph 400/690V-50Hz
MOTOR Rotation speed R.P.M.	1450
Rated power P2 (kW)	35,7
Rated current I (A)	63,6
Starting current Is (A)	375
Weight (Kg)	520
Cable	H07RN/F 2x4G10+4G2,5

SOTR OBTAINED FOLLOWING STANDARD UNI EN 12255-15:2004

Dimensioni - Dimensions - Dimensions - Abmessungen - Dimensiones - Габариты (mm)

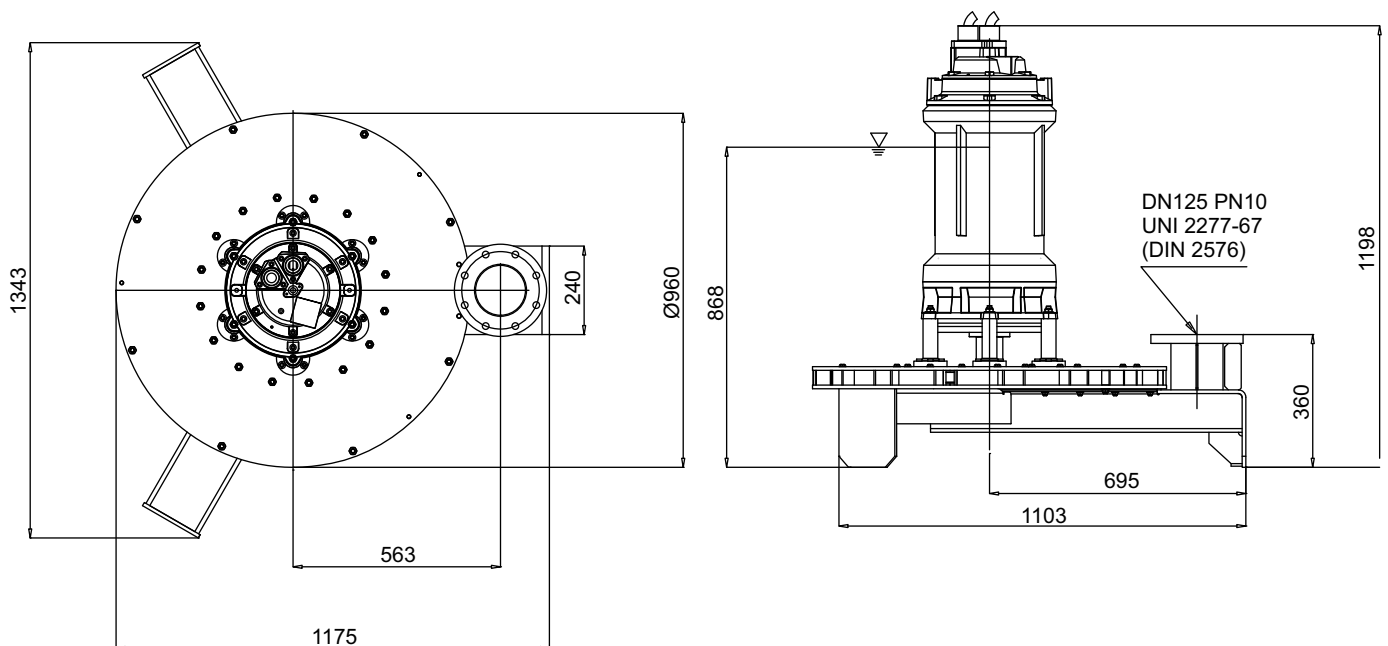

LIVELLO MINIMO DI SOMMERGIBILITÀ - MINIMUM SUBMERSIBLE LEVEL - NIVEAU MINIMUM D'IMMERSION
 MINDESTWASSERSTAND - NIVEL SUMERGIBLE MÍNIMO - МИНИМАЛЬНАЯ ГЛУБИНА ПОГРУЖЕНИЯ