

DG-I



The DG-I pump is a highly efficient chopper pump that is designed to pump heavily contaminated liquids as well as liquids with a high dry matter content.

All DG-I pumps are equipped with a knife system at the inlet to the pump, which ensures problem-free operation under conditions where many other pumps have problems with clogging.

APPLICATION EXAMPLES

- Sewage treatment plants
- Pump stations
- Biogas plants
- Food industry
- Pumping abrasive liquids or liquids with high viscosity



PUMP RPM

1,500 rpm

MATERIAL OF CONSTRUCTION

Motor housing and oil chamber	Cast iron EN-GJL-250
Pump housing	Cast iron EN-GJL-250
Pump impeller	Cast iron EN-GJL-250 Cast iron EN-GJS-700-2 (optional) W1.4408/AISI316 (optional)
Pump Shaft	W1.6582/AISI4340
Bolts	A4
Sealing system	Mechanical shaft seal: silicon carbide/silicon carbide
Knife system	Hardened steel W1.0038/S235JR W1.4404/AISI316 (optional)
Extended knife system	Hardened steel W1.0038/S235JR (optional) W1.4404/AISI316 (optional)
Oil type	15W-40 Vario HDX (with moisture detection)

SERVICE AND MAINTAINANCE

Recommended service interval/oil change	Maximum 2,000 operating hours/minimum once a year
Motor	Lifetime lubricated bearings
Oil chamber	Periodic oil change

SURFACE TREATMENT

Machinery enamel: RAL 9005 (Jet Black)	Jet Black
2-component coating: RAL 7005 (Mouse Grey) (optional)	Mouse Grey

ELECTRICAL CABLE

H07RN-F/S07RN-F EUCAFLEX^{Plus} Cable.

Resistant to oil and UV radiation.

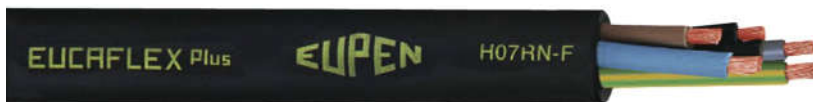

Number of conductors:

H07RN-F 7G1.5 mm² (Not used in United Kingdom)

H07RN-F 7G2.5 mm² (Only United Kingdom. Motor ≤ 5,5 kW)

S07RN-F 7G4+3x1.5 mm²

S07RN-F 7G6+3x1.5 mm²

As standard supplied with 7 m of cable (extra length available upon request).

MONITORING FUNCTIONS

Bimetal thermal sensors 120 °C

Moisture detection system (optional)

ELECTRICAL DATA

Motor type	3-phase AC motor
Nominal voltage	400 V
Minimum voltage allowed	360 V
Nominal frequency	50 Hz
Applicable for VFD operation	Yes
Ingress protection rating	IP 68
Insulation class	F
ATEX classification	II 2 G Ex d c IIB T4 Gb (Option, only available for specific models)

Model	Nominal power	Motor	Full load current (400 V)	Connection method	Start current (DOL)	cos phi	Efficiency
	[kW]	[rpm]	[A]	Y/Δ	[A]		[%]
Medium pressure							
DG-I 50 0,75 kW-1500 rpm	0,75	1400	2,1	Y	10	0,70	73,6
DG-I 65 2,2 kW-1500 rpm	2,2	1410	5,0	Y	30	0,80	80,2
DG-I 80 4,0 kW-1500 rpm	4,0	1435	8,8	Δ	61	0,78	84,1
DG-I 80 5,5 kW-1500 rpm	5,5	1440	11,0	Δ	68	0,87	84,6
DG-I 105 11,0 kW-1500 rpm	11,0	1455	21,5	Δ	146	0,84	87,9
DG-I 105 18,5 kW-1500 rpm	18,5	1460	35,0	Δ	238	0,85	89,3

For voltages others than 400 V/50 Hz please refer to the attached Appendix.

OVERALL DIMENSIONS

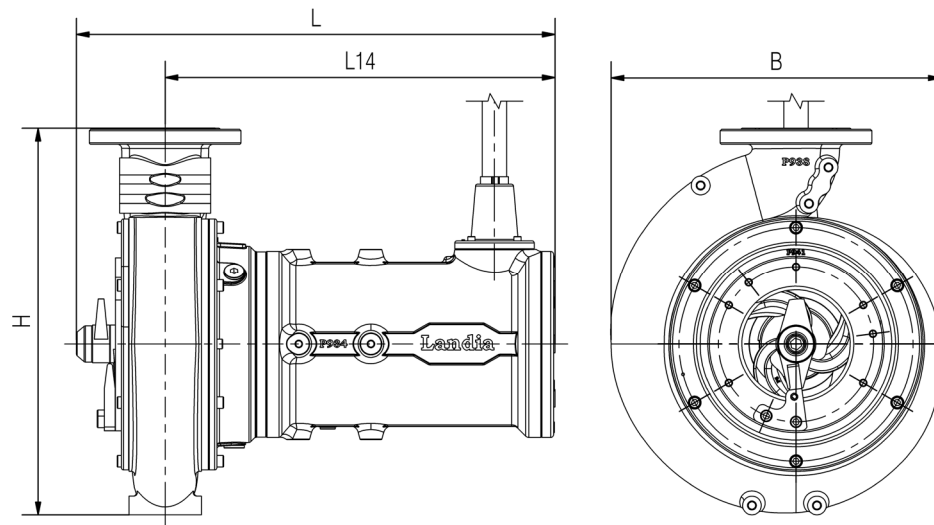

Model	B [mm]	H [mm]	L [mm]	L14 [mm]	Weight [kg]
Medium pressure					
DG-I 50 0,75 kW-1500 rpm	250	290	360	290	25
DG-I 65 2,2 kW-1500 rpm	320	371	450	366	55
DG-I 80 4,0 kW-1500 rpm	370	432	550	445	85
DG-I 80 5,5 kW-1500 rpm	370	432	580	480	100
DG-I 105 11,0 kW-1500 rpm	460	534	665	540	160
DG-I 105 18,5 kW-1500 rpm	460	534	710	585	210

We reserve the right to make technical changes.