

AJ400G420R440SA

SOTR

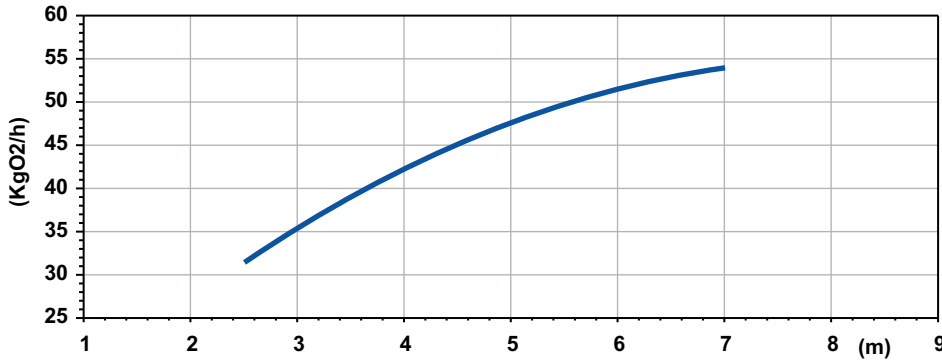

Potenza Assorbita - Absorbed Power P1
 Puissance Absorbée - Leistungsaufnahme P1
 Potencia Absorbida - Поглощенная мощность P1

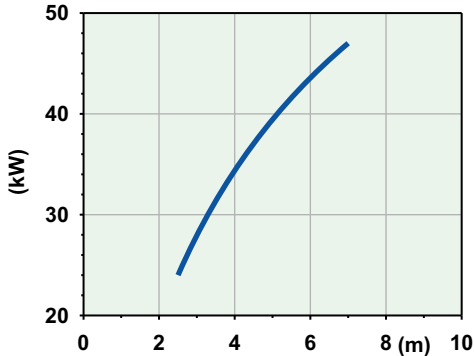

Battente idraulico - Hydraulic head - Charge hydraulique - Hydraulischen Belastung
 Cabezal hidráulico - Гидронапор

Aria Aspirata - Suction Air
 L'air D'aspiration - Saugluft
 Succión De Aire - Аспирированный воздух
 Nm^3/h a $0^\circ C$, $RH 0\%$, $p = 101,3 kPa$

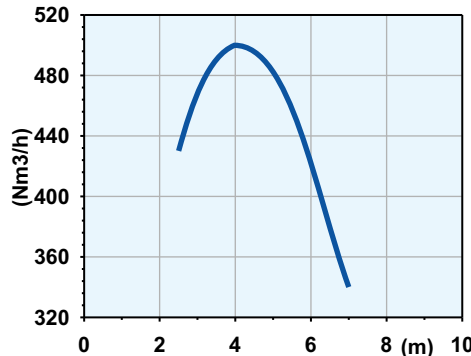

Code	5009661
Type	AJ400G420R440SA
Suction (mm)	DN150
Free passage (mm)	40x50
Immersion depth (m)	2,5-7
Motor type	M420T-44-400/50YY-IE3
Power supply	3ph 400/690V-50Hz
MOTOR Rotation speed R.P.M.	1455
Rated power P2 (kW)	44
Rated current I (A)	78,1
Starting current Is (A)	461
Weight (Kg)	790
Cable	H07RN/F 2x4G10+4G2,5
SOTR OBTAINED FOLLOWING STANDARD UNI EN 12255-15:2004	

Dimensioni - Dimensions - Dimensions - Abmessungen - Dimensiones - Габариты (mm)

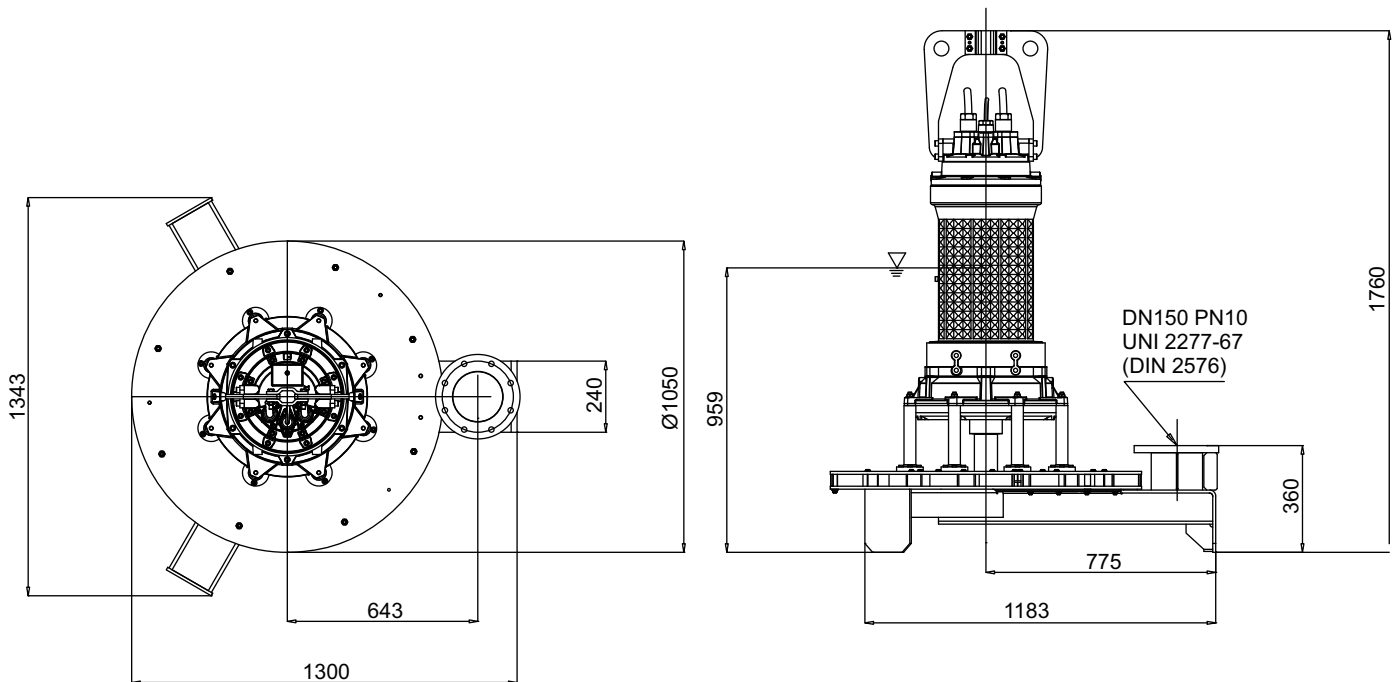

LIVELLO MINIMO DI SOMMERGIBILITÀ - MINIMUM SUBMERSIBLE LEVEL - NIVEAU MINIMUM D'IMMERSION
 MINDESTWASSERSTAND - NIVEL SUMERGIBLE MÍNIMO - МИНИМАЛЬНАЯ ГЛУБИНА ПОГРУЖЕНИЯ