

OPERATING LIMITS

Flow rates up to:	120 m ³ /h
Head up to:	43 m
Max. discharge pressure:	13 bar up to +140°C
	16 bar up to +120°C
Temperature range:	-20° à +140°C
Max. ambient temperature:	+40°C
Flanges ND:	40 à 80

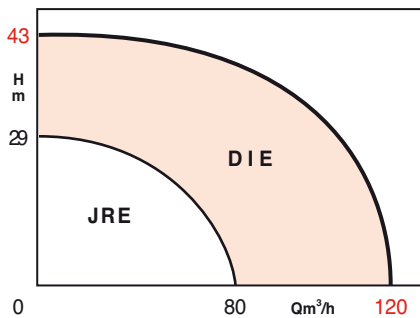

ADVANTAGES

- **ENERGY SAVINGS**
 - Pumps duty point optimization.
 - Up to 50% energy savings compare to standard pumps.
- **NOISE CONTROL**
 - Whistling and noise elimination at thermostatic valves.
 - Automatic speed adaptation for comfort needs.
- **RELIABILITY**
 - The fully automatic running requires neither sensor maintenance nor drain.
 - Electronic set equipped with non volatile memory for data storage, settings protection in case of electricity shortage.
 - Protection Index IP 54 for motor/set package in case of dust and humid surroundings. For twin pumps (DIE equipped with 2 IF modules), automatic permutation without external control.
- **SIMPLICITY**
 - Only one button controls function choice and settings adjustment.
 - Adjustments always viewable on LCD screen.

DIE

TWIN HEAD PUMPS IN-LINE ELECTRONIC CONTROL Heating - Air conditioning S.H.W. 50 Hz

APPLICATIONS

Capable of handling cold and hot water without abrasive particles for circulating, transfer and booster duties.

When used to handle additives such as water/glycol or similar thin non-corrosive fluids it will be necessary to check the suitability of the standard mechanical seal as well as to reassess duty point and system calculations (necessary for glycol contents above 10%)..

• Approved fluids:

- Heating water to VDI 2035
- Service water - chilled/condenser water
- Water/glycol-mixtures¹⁾
- Heat transfer fluids²⁾
- Other media on request³⁾

Performance

Speed range 1100-2900 rpm.
Infinitely-variable speed control.

1) Applies to 20 - 40 % vol. glycol content and up to 40° C fluid temperature

2) Special design at extra cost

3) Special design at extra cost

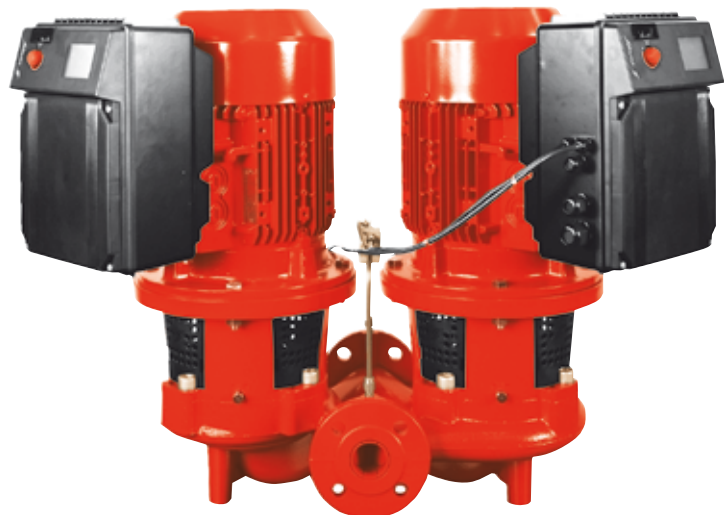

DIE

DESIGN

• Hydraulic part

- In-line single-stage low pressure centrifuge pump with suction and discharge flanges of the same nominal diameter, with an air-cooled standard IEC motor.
- NP 16 holed flanges compliant with EN 1092-2.
- G 1/8 pressure gauge couplings used for the built-in differential pressure sensor.
- The pump body has serial bosses designed for a maximum operating pressure of 16 bars.
- The motor shaft coupling is rigid.
- The body and the closed impeller are made from grey cast iron.
- The mechanical seal does not require maintenance and is independent of the rotation direction. It is suitable for pure water of a temperature up to 140°C and water/glycol mixtures of a volume up to 40% and a maximum temperature of 40°C¹⁾.
- Special seals and sealing materials are available for other uses.

• Motor

Integrated full overload protection by PTC thermal sensor in all stator windings.

- Three-phase squirrel cage electric motor power supply: 3~400 V, 50 Hz
3~380 V, 60 Hz

Protection index: IP 54
Insulating category: 155 (F)
Conformity CEM: EN 61800-3

Protection differential (FI)

Selective "all current" FI differential circuit breakers are permitted (> 300 mA trip rating).

Ident. mark FI 

STANDARD CONSTRUCTION

Main parts	Material
Pump casing	EN-GJL 250 ²⁾
Impeller	EN-GJL 200 ³⁾ G-CuSn 5 ⁴⁾
Lantern	EN-GJL 250
Shaft	1,4122/X39CrMo17-1
Mechanical seal	Graphite/Si carbide/EP

* Other mechanical seals⁵⁾ on demand.

- 1) Applies to 20 - 40 % vol. glycol content and up to 40° C fluid temperature
- 2) Previously Ft 25, anti-corrosive treaty
- 3) Previously Ft 20
- 4) Special design at extra cost
- 5) Applicable for water/glycol mixtures differing from those referred in 1)

IDENTIFICATION

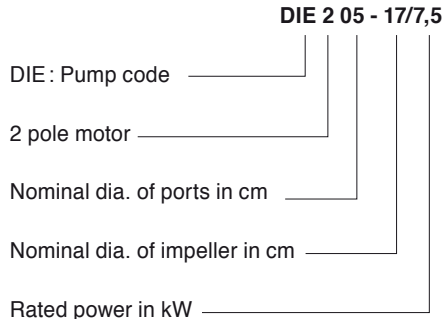

PUMP EQUIPMENT

- **Pump intergrated Δ P-c mode** for constant head control
- **Pump intergrated Δ P-v mode** for variable head control
- **Remote control facility (0 - 10V)** for wiring to an external control unit BMS
- Pump integrated setpoint adjustment
- Graphic Display
- Fault light
- Fault reset button
- Off-line centralised operating signal (closed-circuit contact)
- Centralised fault signal (open-circuit contact)
- External On/Off
- "Analogue 0... 10V**" input
- Space for IF module (interface for double pumps)

INSTALLATION

Series DIE pumps are designed for direct horizontal or vertical inline pipe mounting. The motor or module must not be mounted near the bottom. Leave a space to remove the motor, the lantern ring and the impeller. With motor powers upwards of 5,5kW the motor needs to be supported (mounting in vertical a duct) or a pedestal is required to support the pump body (mounting in a horizontal duct).

MOUNTING POSITIONS

- Pipe supported
 - Bracket or base mounted⁶⁾
- Pipe connections
Flanges PN 16/EN 1092-2

6) Special design at extra cost

FEATURES

• Packaging

The pump, the packaging and the assembly and instruction manual are included as standard.

• Accessories

- Support bracket mounting
- IF module LON⁷⁾

7) See functions charge

DESCRIPTION VIEW

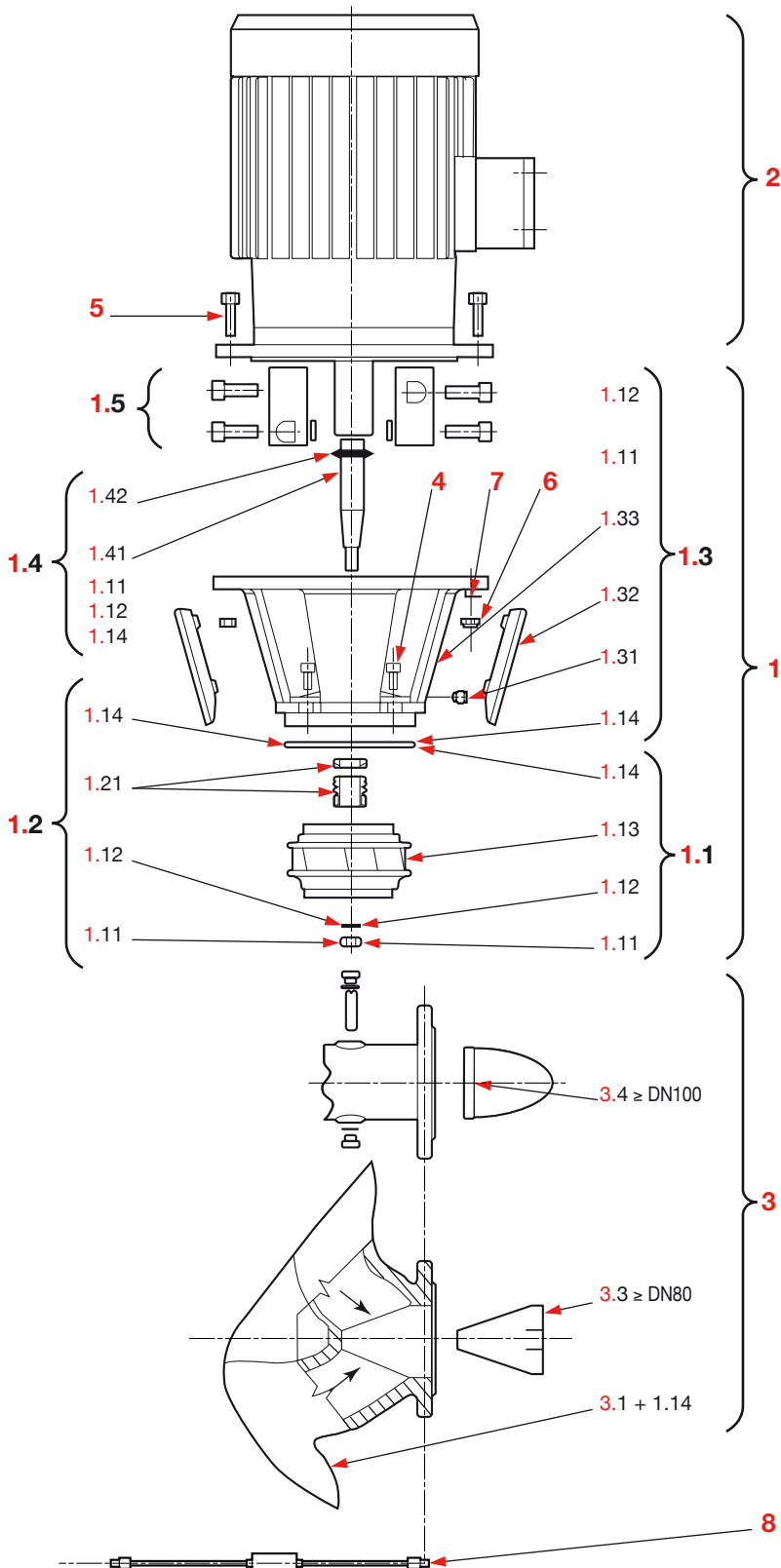

1. Complete exchange batch
 - 1.1 Hydraulic kit with
 - 1.11 Nut
 - 1.12 Washer
 - 1.13 Impeller
 - 1.14 O-ring
 - 1.2 Kit mechanical seal with
 - 1.21 Complete mechanical seal
 - 1.3 Lantern kit parts with
 - 1.31 Bleed screw
 - 1.32 Coupling protector
 - 1.33 Lantern
 - 1.4 Kit shaft with
 - 1.41 Shaft
 - 1.42 Spring stop cellar
 - 1.5 Complete coupling
2. Motor
3. Complete pump casing kit with
 - 3.1 Pump
 - 3.2 Stopper for pressure ports
4. Mounting screw for lantern/pump
5. Mounting screw for motor/lantern
6. Nut for motor/lantern mounting
7. Washer for motor/lantern mounting
8. Differential pressure sensor with pipe.

DIE

IF MODULE

Refit plug-in module for series DIE electronically controlled pumps for the following additional functions:

- Serial digital interface (only on IF module LON) for the connection to Building Management (GTC);
- DP interface for twin pump management with the functions:
 - Main/standby operation with automatic 24 h pump duty cycling,
 - Cascade mode with switching on/off of a 2nd pump at peak loads for optimised energy consumption.



WIRING DIAGRAM

Three-phase 3~400V, 50Hz/380V, 60 Hz

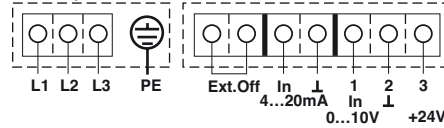

Option : IF module



Switch rating of volt-free contacts for collective Run and Fault signals :

- min. 12 V DC/ 10 mA
- max. 250 V AC/1 A

L1,L2,L3,PE : Power supply 3~400V - 50 Hz – 3~380V - 60 Hz

SSM : Volt-free common Fault signal

SBM : Volt-free common Run signal

3 : Analog input 24 V DC for external sensor

2 : Ground (⊥) sensor

1 : Analog input (0 - 10 V) for integrated or external sensor (GTC)

4...20 mA : Analog input (4-20 mA) for remote control impulse (GTC)

Ext. Off : Remote On/Off

DP : Twin pump management (2 pumps)

LON : Serial digital BMS interface (LONWORKS)

FUNCTIONS CHART DIE

Function	Single head pumps DIE
Mains power	
3~400V, 50 Hz	•
3~380V, 60 Hz	•
Manual function	
Pump On/Off	•
Mode selection (Δ p-c, Δ p-v, remote control)	•
Adjusting of the differential pressure setpoint	•
Speed selection (manual remote control)	•
Automatic function	
Infinitely variable speed control Δ p-c	•
Infinitely variable speed control Δ p-v	•
Full motor protection with trip function	•
Remotely controlled function	
Remote On/Off	•
Command input "0...10 V" or "4-20 mA" (remote speed adjustment)	•
Signal and display function	
Collective Run signal (volt-free contacts)	•
Collective Fault signal (volt-free contacts)	•
Fault light	•
Fault code	•
LCD-screen with pump data display	•
Data exchange	
Serial digital interface (LON) for link-up to home system	• ²⁾
Double pump management (2 x single pumps)	
Normal/back up mode (automatic switching in the case of a fault/changing of pump according to time)	• ³⁾
Cascade mode (switching on/off at peak loads for optimised energy consumption)	• ³⁾

²⁾ with 1 of IF-Module (Accessories)

³⁾ with 2 of IF-Modules (Accessories)

GENERAL PRESELECTION CHARTS - 2 POLE - 50HZ

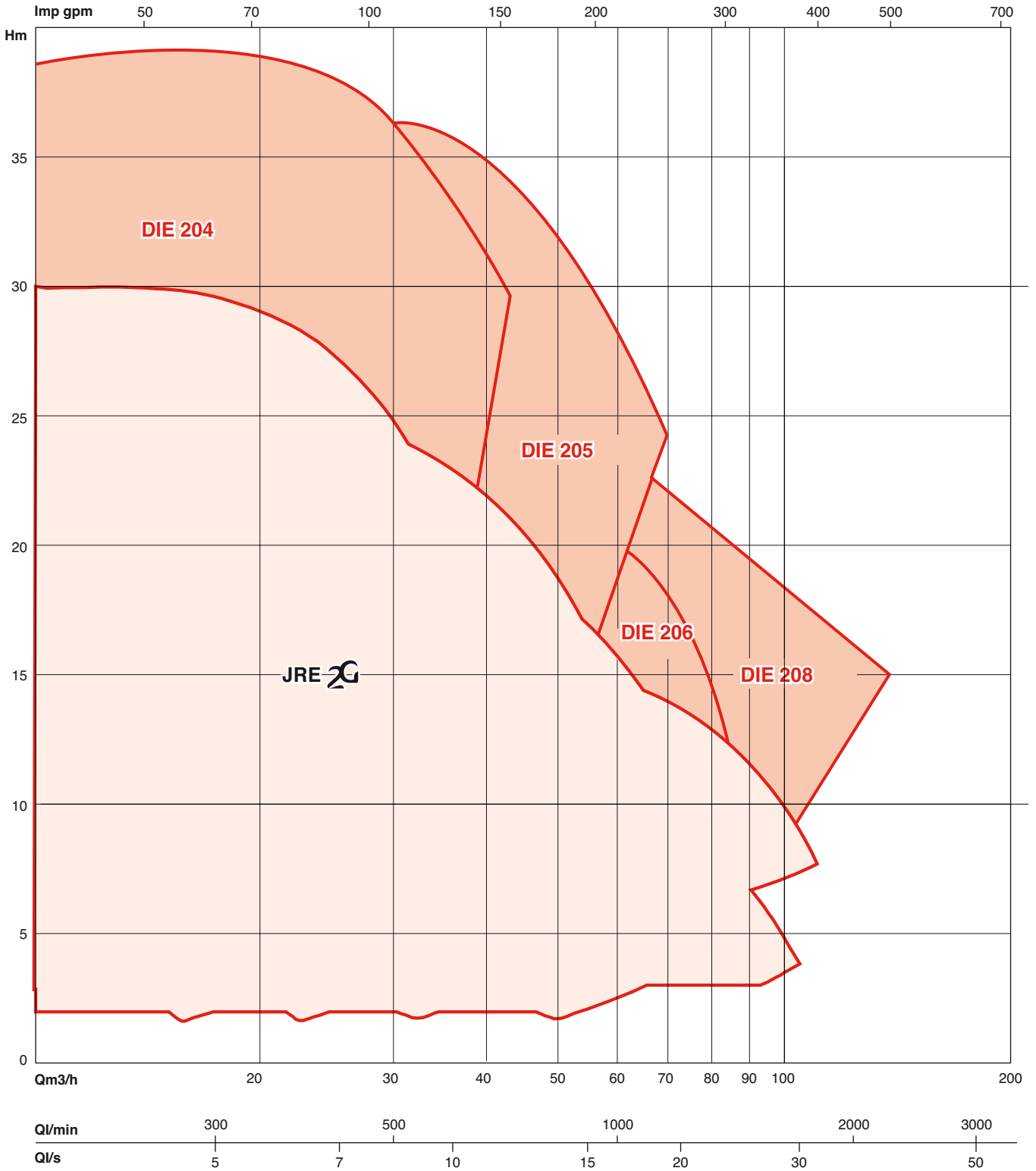

HYDRAULIC PERFORMANCE - NORMAL / BACK UP MODE

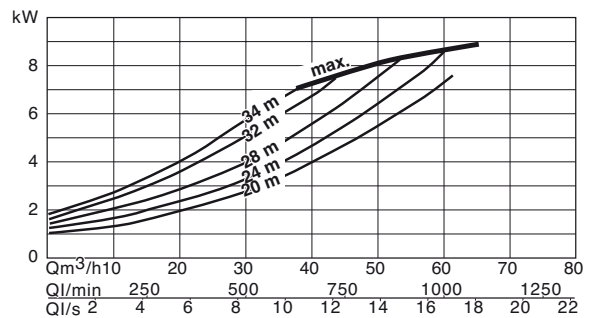
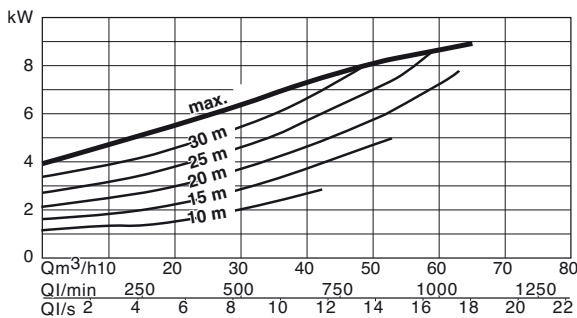
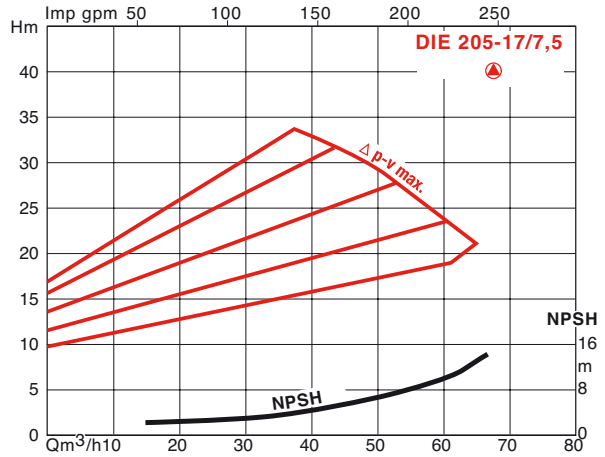
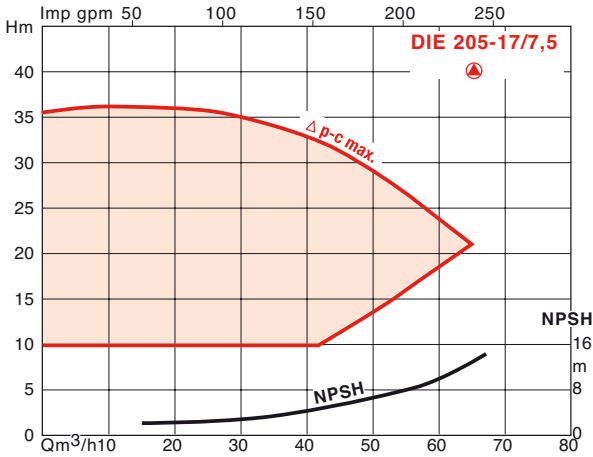
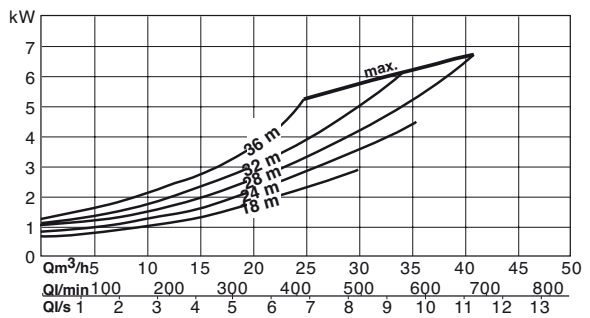
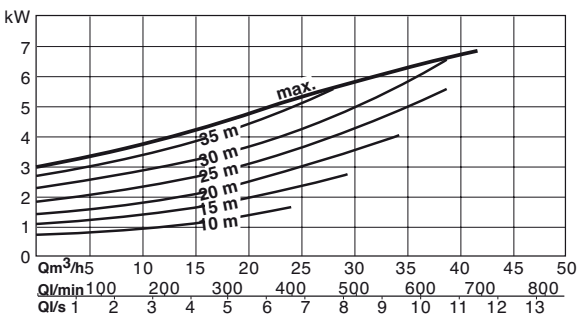
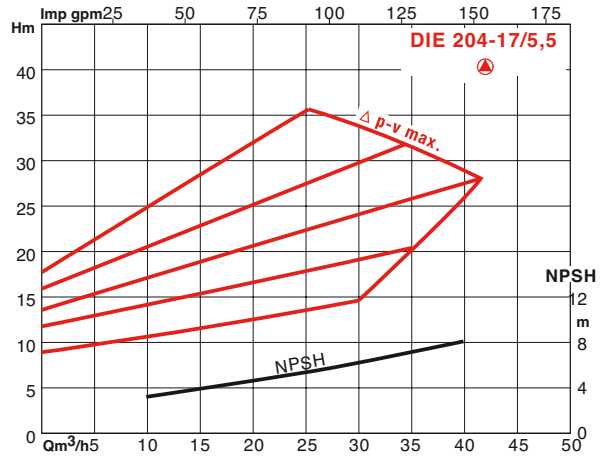
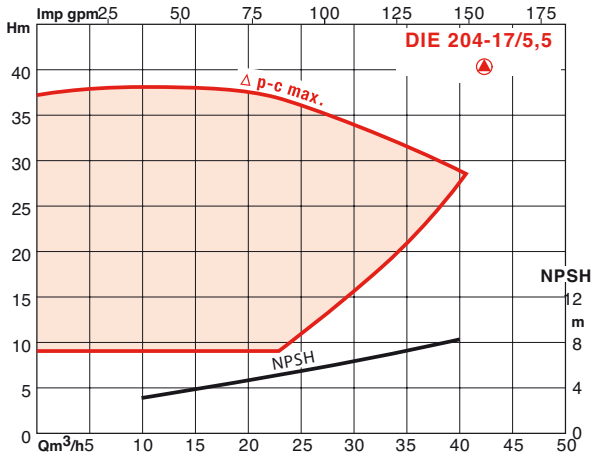

HYDRAULIC PERFORMANCE - NORMAL / BACK UP MODE

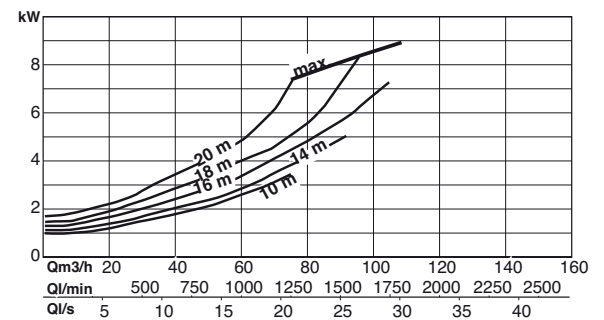
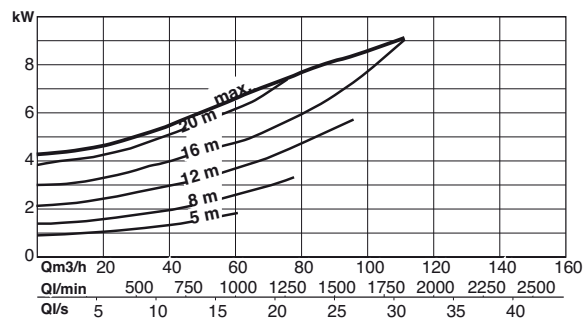
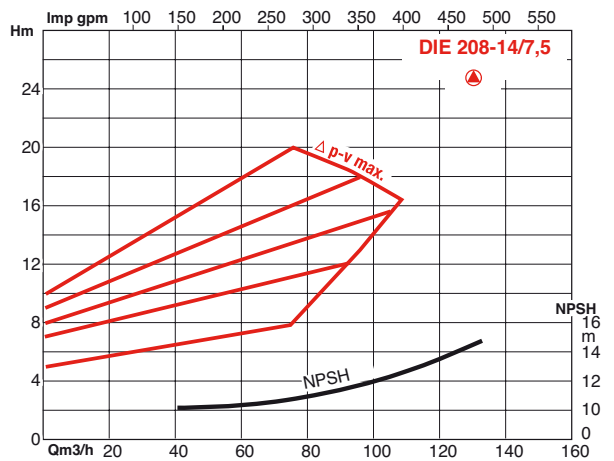
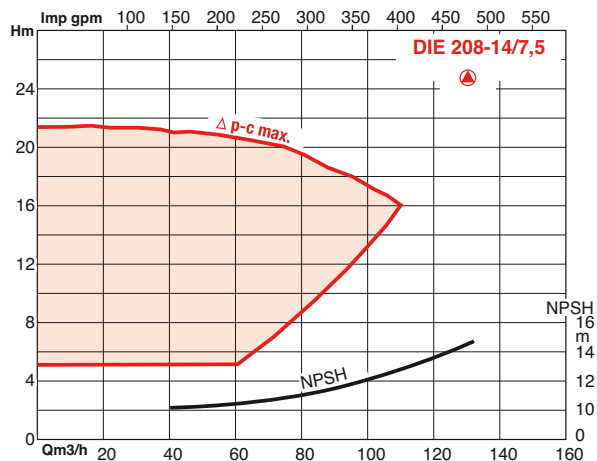
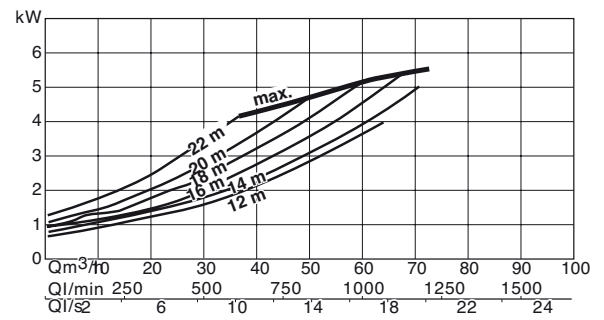
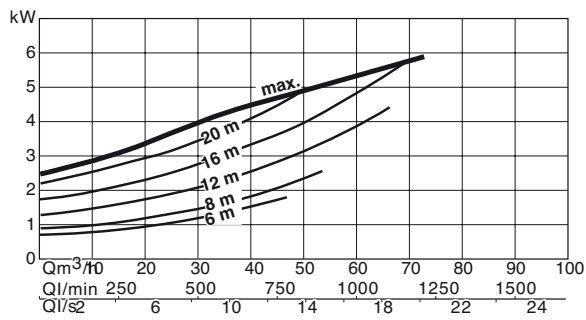
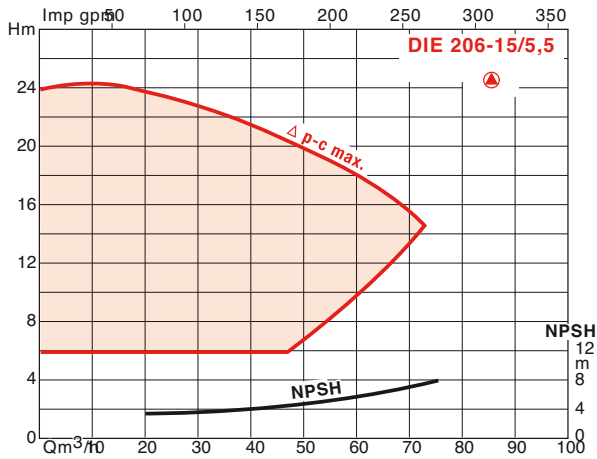

HYDRAULIC PERFORMANCE - 2 PUMPS IN PARALLEL

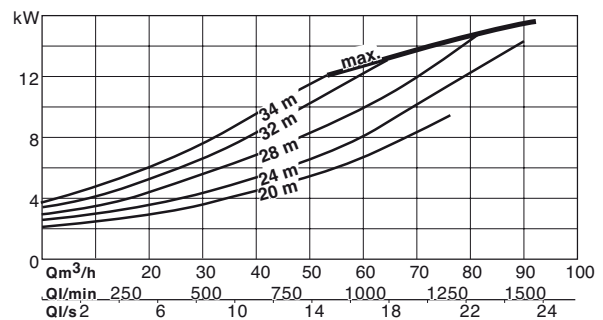
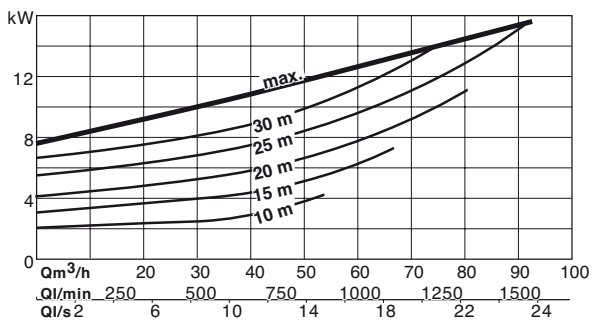
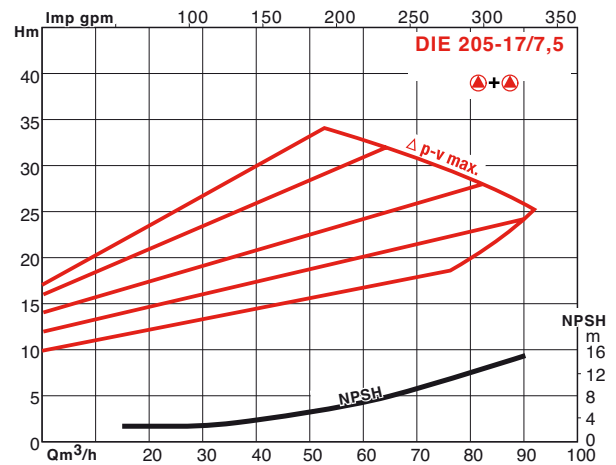
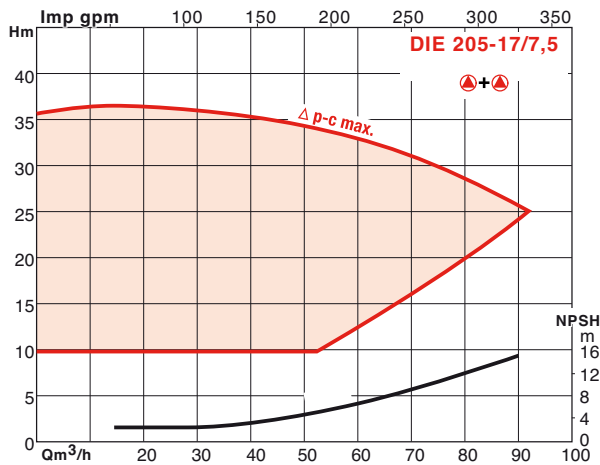
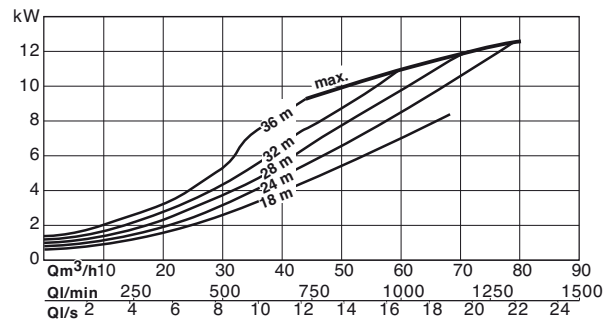
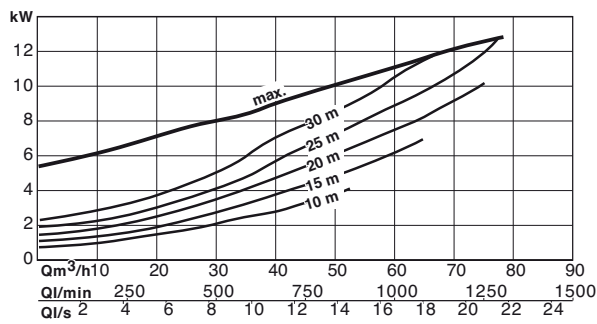
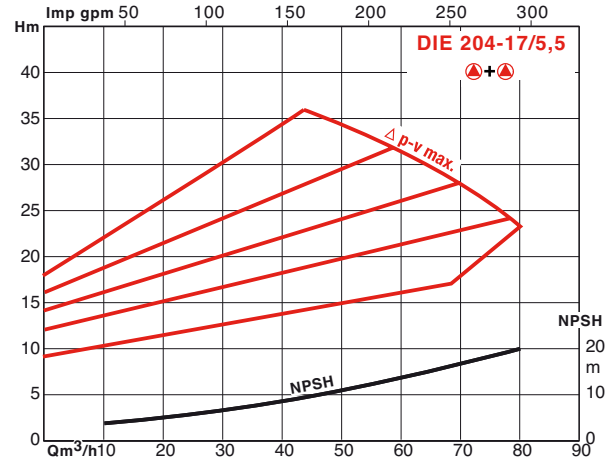
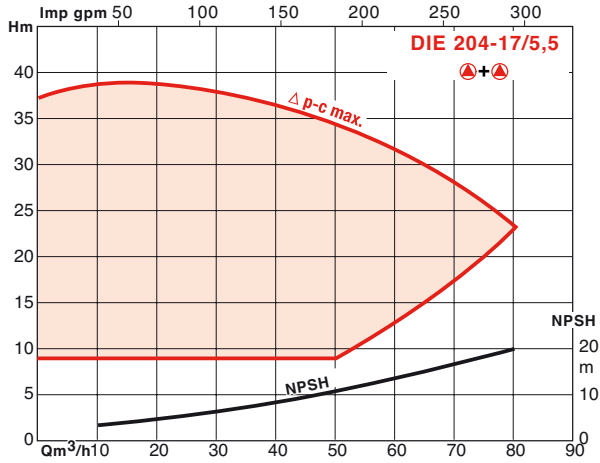

HYDRAULIC PERFORMANCE - 2 PUMPS IN PARALLEL

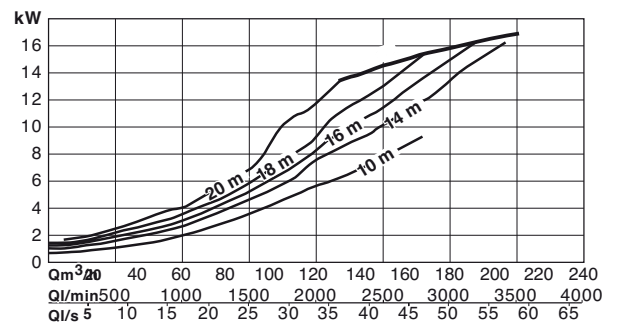
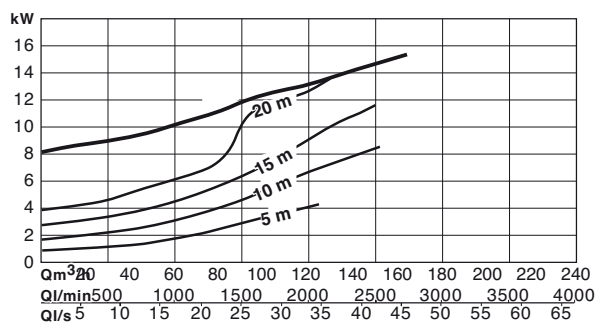
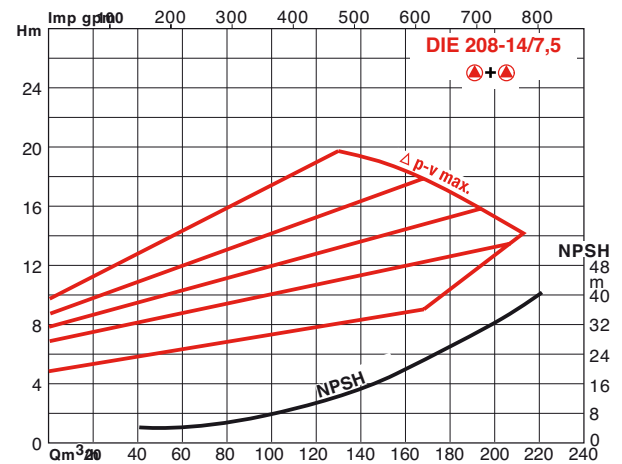
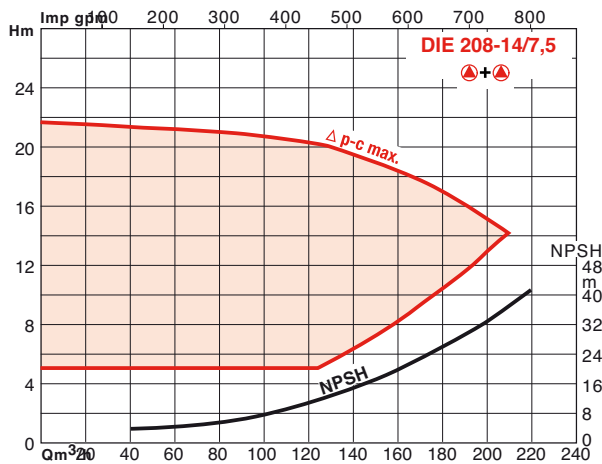
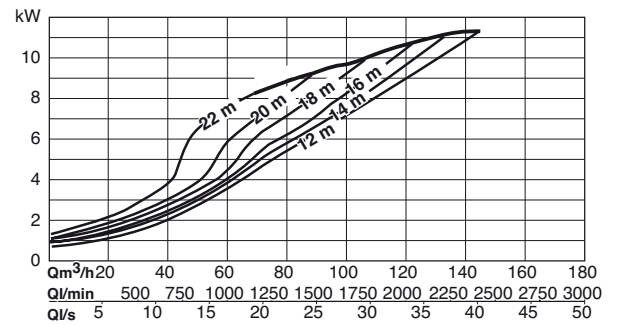
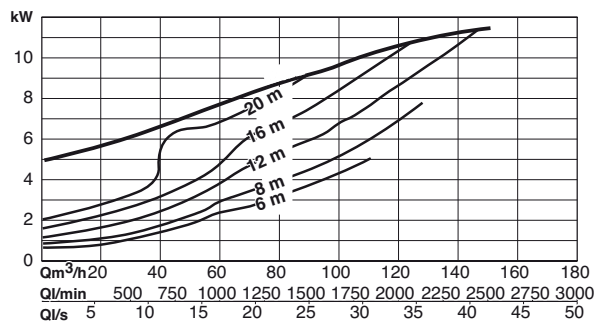
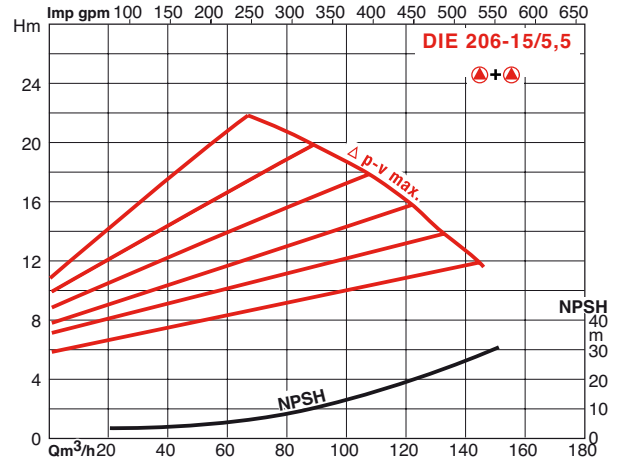
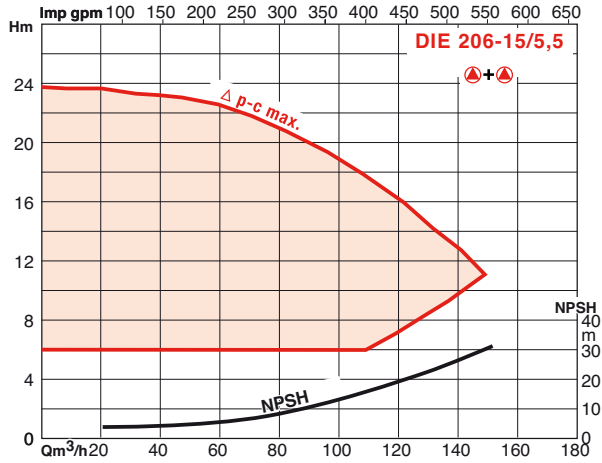

ELECTRIC AND DIMENSIONAL CHARACTERISTICS

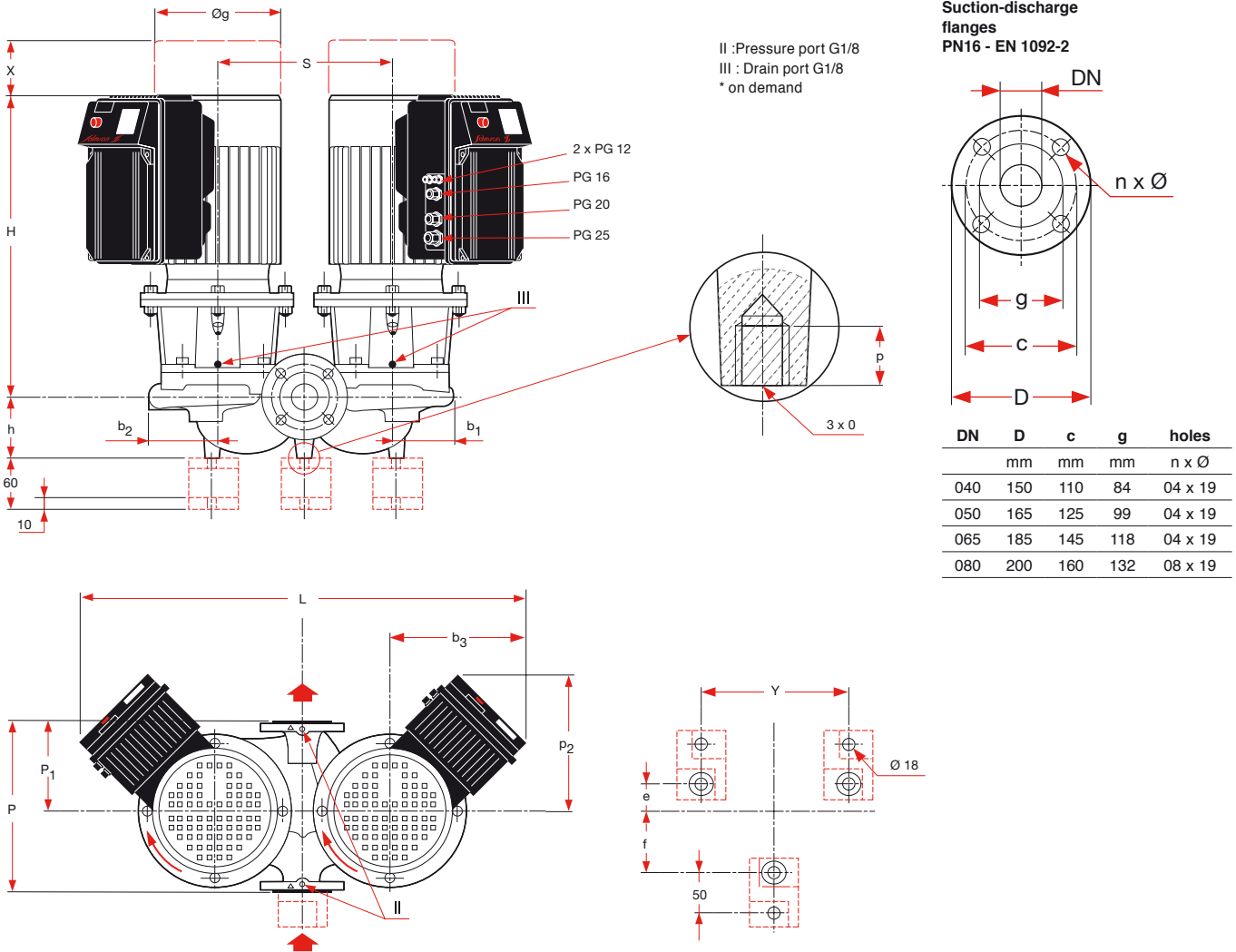

ORDER REFERENCE

MOTOR

PUMP

	P2	Speed	Power input	Nominal	ND	P	h	b1	b2	b3	Y	e	f	Øg	H	P1	O	p	P2	S	X	mass
	kW	tr/mn	P1 max. kW	current in A	ports	mm	mm	mm	mm	mm	mm	mm	mm	mm	mm	mm	mm	mm	mm	mm	mm	kg
DIE 204-17/5,5	5,5	1100-2900	7,2	11,5	40	340	100	120	127	288	400	52	145	266	570	170	M10	20	288	340	95	173
DIE 205-17/7,5	7,5	1100-2900	9,3	14,5	50	340	120	126	136	288	360	50	130	266	567	180	M10	20	288	340	100	203
DIE 206-15/5,5	5,5	1100-2900	7,2	11,5	65	430	154	134	144	288	440	55	185	266	586	215	M12	20	288	400	120	202
DIE 208-14/7,5	7,5	1100-2900	9,3	14,5	80	400	135	134	146	288	400	62	178	266	591	200	M12	20	288	350	120	210