

Elettropompe con motore flangiato per liquidi carichi in camera asciutta
Dry installed sewage electric pumps with flanged motor
 Electropompes pour eaux chargées en fosse sèche

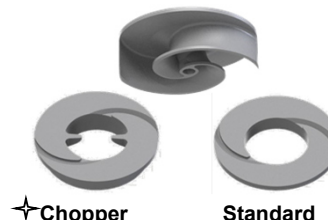

CURVA - Curve - Courbe		POMPA Pump Pompe		DN	GIRI /Min - RPM. - Tours/min.	POTENZA MOTORE Motor rating Puissance moteur	PESO Weight Poids
N°						kW	*Kg
1	KBM 150/6-245 A4 L3	150	960	4	170		

Girante bicanale aperta e diffusore autopulente
Two channel open impeller and self-cleaning diffuser
 Roue à 2 canaux ouvert et anneau autonettoyant



* Peso indicativo

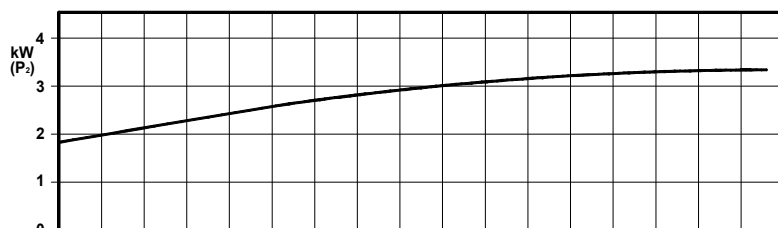
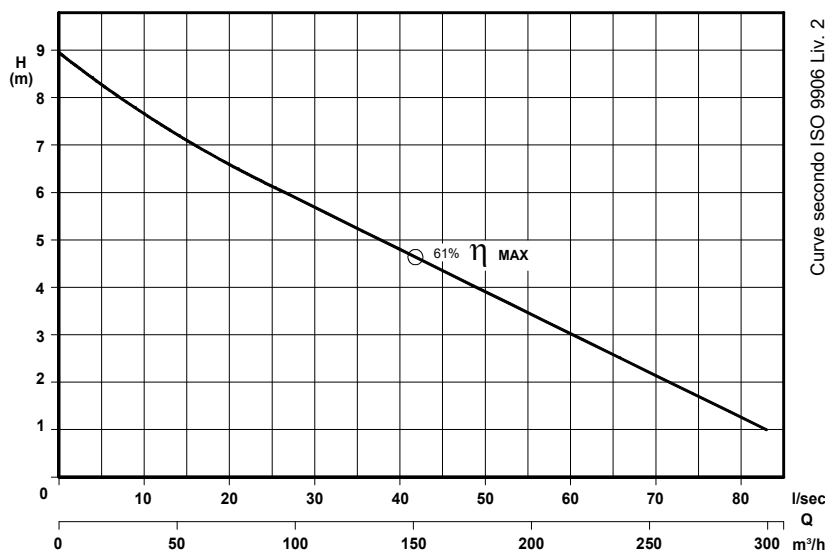

P₂ - Potenza resa - Shaft power - Puissance sur arbre

COSTRUZIONE - Materials - Matériaux

Fusioni principali - Principal parts - Parts principal	Ghisa - Cast iron - Fonte - GG 25
Girante - Impeller - Roue	Ghisa - Cast iron - Fonte - GS 500
Albero - Shaft - Arbre	AISI 420
Viteria - Screws - Vis	AISI 304

Mechanical seals - Garniture mécanique

Doppia tenuta meccanica in bagno d'olio - Double mechanical seals in oil bath - Double garniture mécanique en chambre d'huile
 Tenuta lato motore / tenuta lato liquido : carburo di silicio
 Motor side / liquid side mechanical seal : silicon carbide
 Garniture mécanique côté du moteur / côté liquide : carbure de silicium

CARATTERISTICHE TECNICHE - Technical Features - Caractéristiques Techniques

Motore - Motor - Moteur : B5 IP55 Classe isolamento - Insulating class - Isolement classe : F
 Max. temperatura liquido - Max liquid temp. - Max Temperature du liquide: 60°C
 pH Liquido da sollevare - pH raised fluid - pH du liquide à relever: 6 - 10

INSTALLAZIONE ORIZZONTALE - Horizontal installation - Installation Horizontale

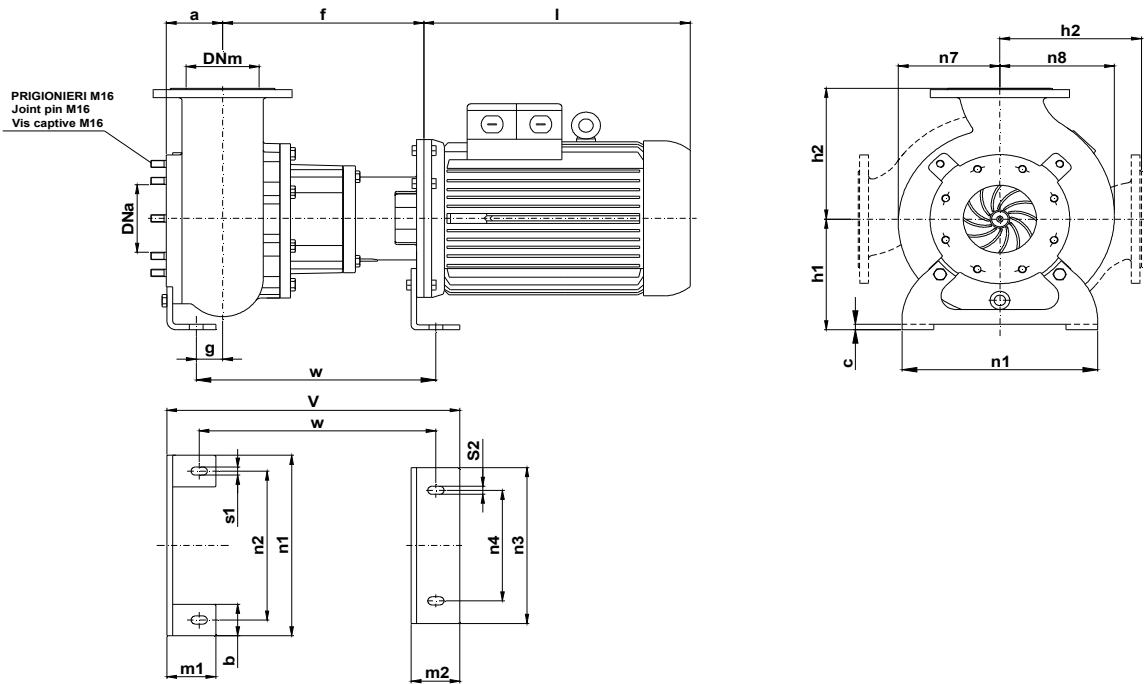

POMPA Pumps Pompe	DNa DNm	Gr. Motore Motor size Taille du moteur	a	b	c	f	g	h1	h2	l	m1	m2	n1	n2	n3	n4	n7	n8	s1	s2	v	w
KBM 150 -	150	132	115	70	12	348	46	245	290	435	100	100	400	330	300	200	210	240	18	18	544	431

Dimensioni - Size - Dimensions in mm.

INSTALLAZIONE VERTICALE - Vertical installation - Installation verticale

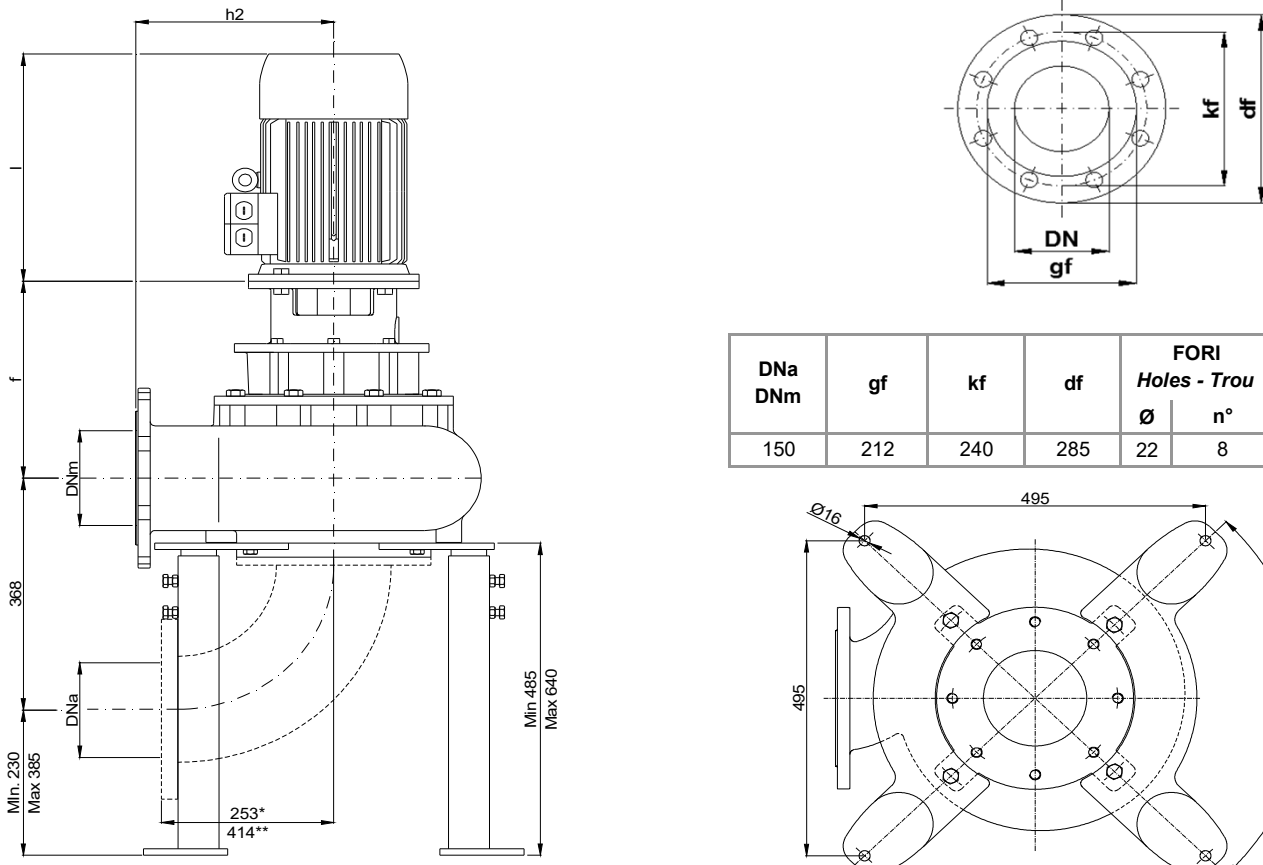

DNa DNm	gf	kf	df	FORI Holes - Trou	
				Ø	n°
150	212	240	285	22	8

* Curva dima - Curve standard : 3

** Curva dima - Curve standard: 5

KBM 150/6-280-1-17X.0

Con riserva di variazioni tecniche e costruttive senza preavviso.

With reserve of technical and constructive variations without warning. - Avec réserve de variations techniques et constructives sans préavis.

POMPE ROTOMECH srl - 20063 CERNUSCO SUL NAVIGLIO (MI) - ITALY - Via Ponchielli, 1

Tel.02 9211.0205 - 02 9233.0399 Fax 02 9211.0630 Sito Internet: www.pomperotomec.it E-mail: sales@pomperotomec.it



POMPE ROTOMECC

KBM 150/6-280.2

DN 150

960 rpm

Elettropompe con motore flangiato per liquidi carichi in camera asciutta
 Dry installed sewage electric pumps with flanged motor
 Electropompes pour eaux chargees en fosse sèche



CURVA - Curve - Courbe		POMPA Pump Pompe	DN	GIRI /Min - RPM. - Tours/min.	POTENZA MOTORE Motor rating Puissance moteur	PESO Weight Poids
N°						
1	KBM 150/6-265 A4 L3	150	960	5,5	180	
2	KBM 150/6-275 A4 L3					

* Peso indicativo

Girante bicanale aperta e diffusore autopulente
 Two channel open impeller and self-cleaning diffuser
 Roue à 2 canaux ouvert et anneau autonettoyant

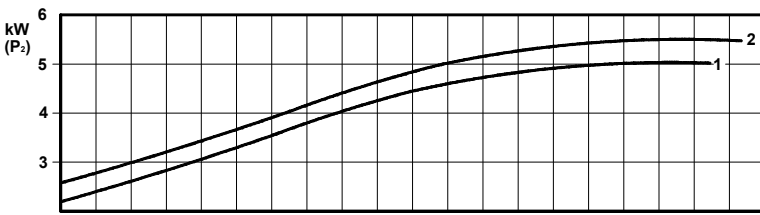
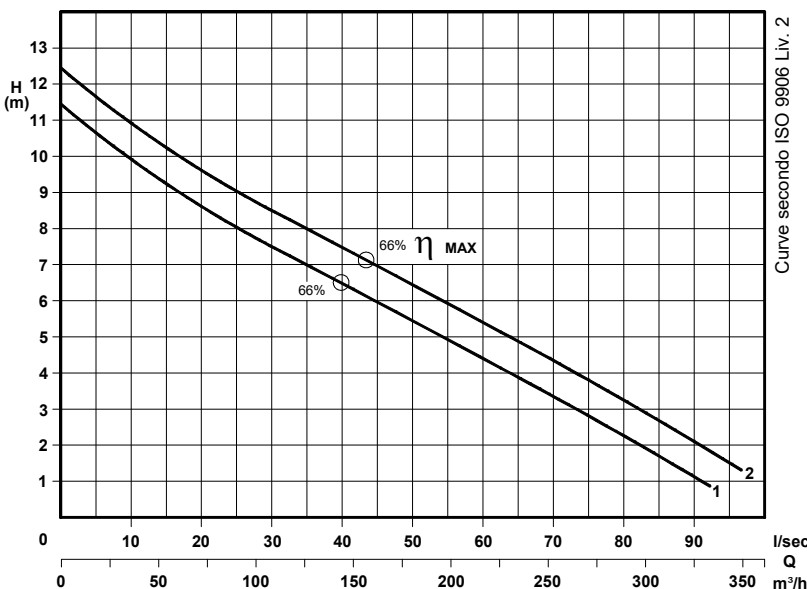
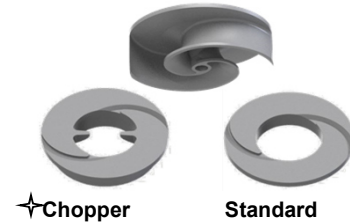

P2 - Potenza resa - Shaft power - Puissance sur arbre

✦ Versione chopper con diffusore a taglienti e girante induriti
 Chopper version with cutting diffuser and impeller hardened
 Version chopper avec anneau tranchant et roue durci

COSTRUZIONE - Materials - Matériaux

Fusioni principali - Principal parts - Parts principal	Ghisa - Cast iron - Fonte - GG 25
Girante - Impeller - Roue	Ghisa - Cast iron - Fonte - GS 500
Albero - Shaft - Arbre	AISI 420
Viteria - Screws - Vis	AISI 304

mechanical seals - Garniture mécanique

Doppia tenuta meccanica in bagno d'olio - Double mechanical seals in oil bath - Double garniture mécanique en chambre d'huile

Tenuta lato motore / tenuta lato liquido : carburo di silicio

Motor side / liquid side mechanical seal : silicon carbide

Garniture mécanique côté du moteur / côté liquide : carbure de silicium

CARATTERISTICHE TECNICHE - Technical Features - Caractéristiques Techniques

Motore - Motor - Moteur : B5 IP55

Classe isolamento - Insulating class - Isolement classe : F

Max. temperatura liquido - Max liquid temp. - Max Temperature du liquide: 60°C

pH Liquido da sollevare - pH raised fluid - pH du liquide à relever: 6 - 10

INSTALLAZIONE ORIZZONTALE - Horizontal installation - Installation Horizontale

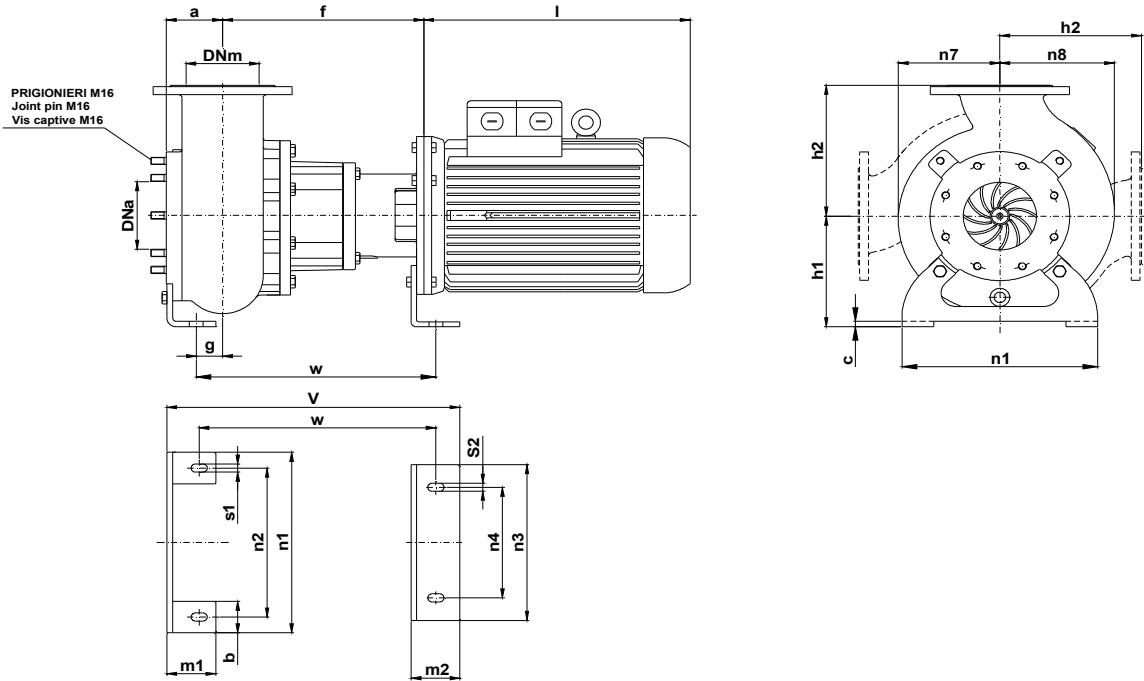

POMPA Pumps Pompe	DNa DNm	Gr. Motore Motor size Taille du moteur	a	b	c	f	g	h1	h2	l	m1	m2	n1	n2	n3	n4	n7	n8	s1	s2	v	w
KBM 150 -	150	132	115	70	12	348	46	245	290	435	100	100	400	330	300	200	210	240	18	18	544	431

Dimensioni - Size - Dimensions in mm.

INSTALLAZIONE VERTICALE - Vertical installation - Installation verticale

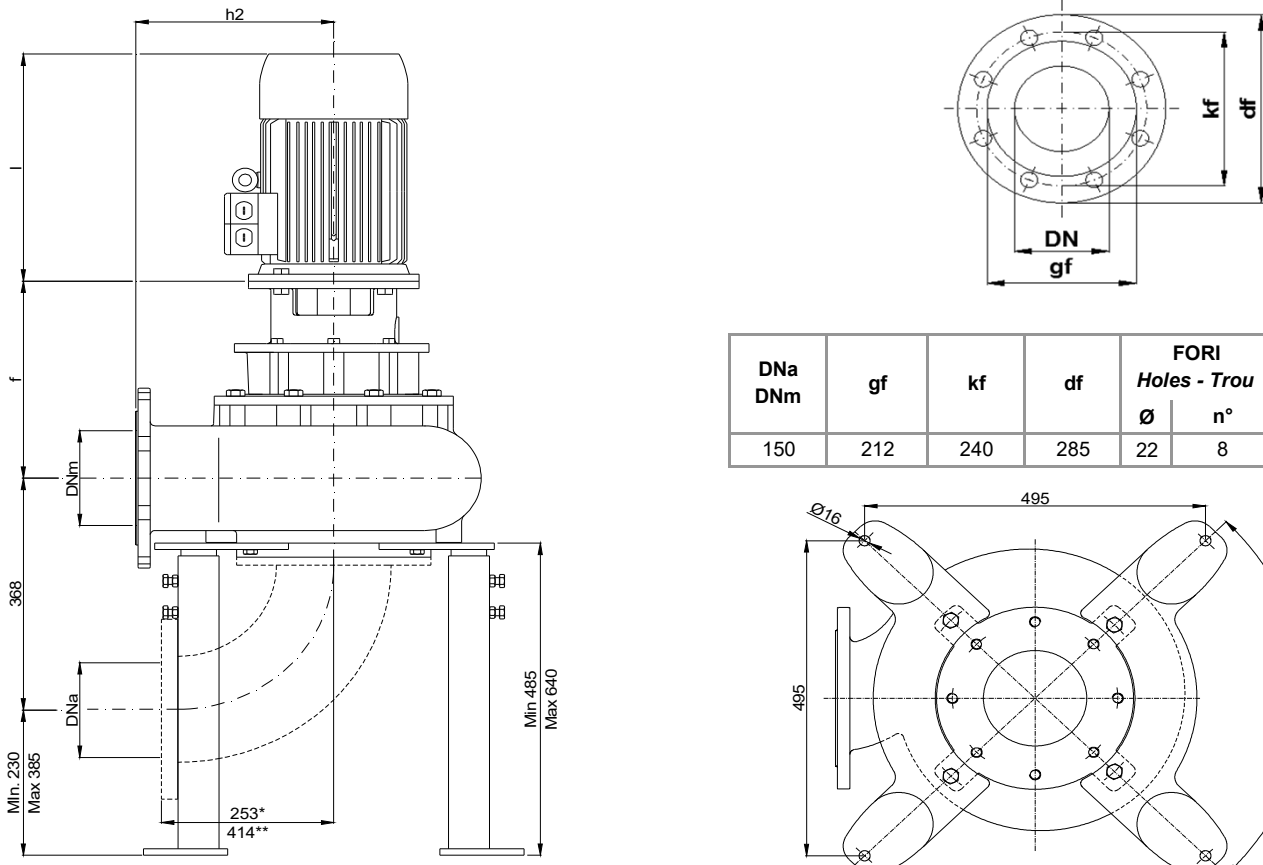

DNa DNm	gf	kf	df	FORI Holes - Trou	
				Ø	n°
150	212	240	285	22	8

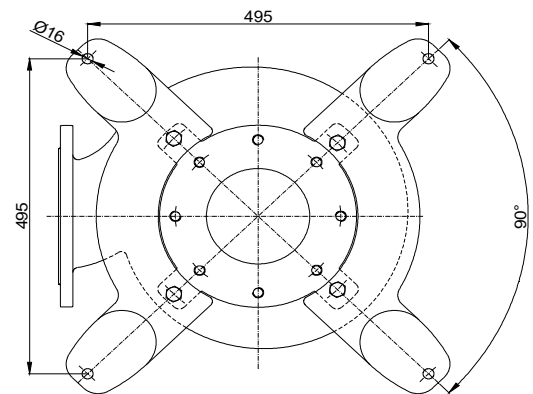

* Curva dima - Curve standard : 3

** Curva dima - Curve standard: 5

KBM 150/6-280-2-17X.0

Con riserva di variazioni tecniche e costruttive senza preavviso.

With reserve of technical and constructive variations without warning. - Avec réserve de variations techniques et constructives sans préavis.

POMPE ROTOMECH srl - 20063 CERNUSCO SUL NAVIGLIO (MI) - ITALY - Via Ponchielli, 1

Tel.02 9211.0205 - 02 9233.0399 Fax 02 9211.0630 Sito Internet: www.pomperotomec.it E-mail: sales@pomperotomec.it

Elettropompe con motore flangiato per liquidi carichi in camera asciutta
Dry installed sewage electric pumps with flanged motor
Electropompes pour eaux chargées en fosse sèche

CURVA - Curve - Courbe		POMPA Pump Pompe		DN	GIRI /Min - RPM - Tours/min.	POTENZA MOTORE Motor rating Puissance moteur	PESO Weight Poids
N°						kW	Kg
1	KBM 150-205 A5 L3	150	1450	5,5	187		

Girante bicanale aperta e diffusore autopulente
Two channel open impeller and self-cleaning diffuser
Roue à 2 canaux ouvert et anneau autonettoyant

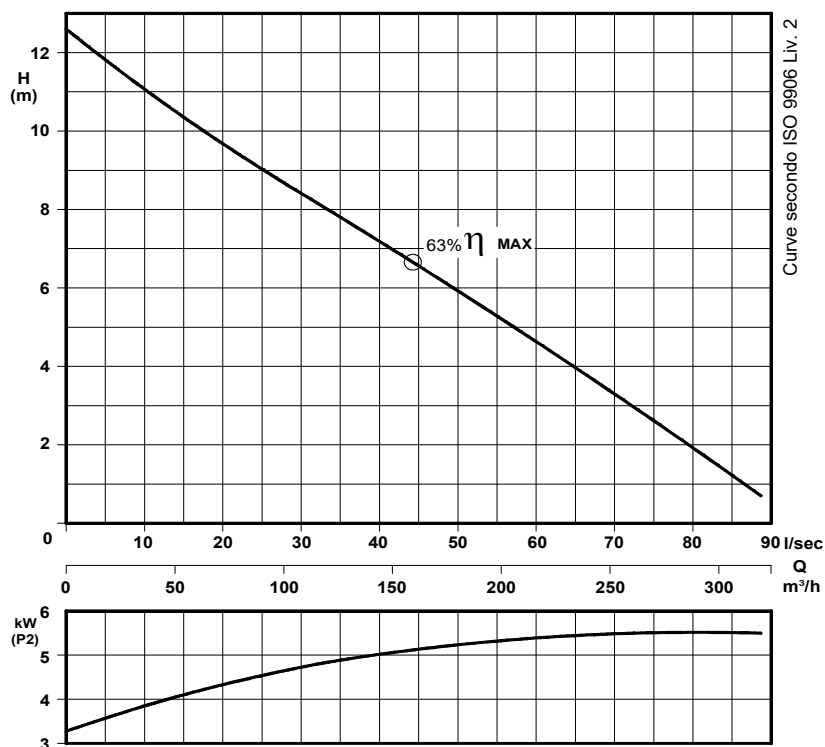
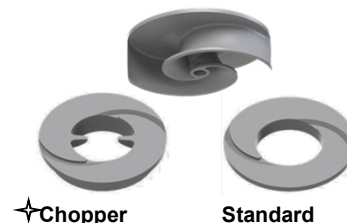

P₂ - Potenza resa - Shaft power - Puissance sur arbre

✦ Versione chopper con diffusore a taglienti e girante induriti
 Chopper version with cutting diffuser and impeller hardened
 Version chopper avec anneau tranchant et roue durci

COSTRUZIONE - Materials - Matériaux

Fusioni principali - Principal parts - Parts principal	Ghisa - Cast iron - Fonte - GG 25
Girante - Impeller - Roue	Ghisa - Cast iron - Fonte - GS 500
Albero - Shaft - Arbre	AISI 420
Viteria - Screws - Vis	AISI 304

TENUTE MECCANICHE - Mechanical seals - Garniture mécanique

Doppia tenuta meccanica in bagno d'olio - Double mechanical seals in oil bath - Double garniture mécanique en chambre d'huile
 Tenuta lato motore / tenuta lato liquido : carburo di silicio
 Motor side / liquid side mechanical seal : silicon carbide
 Garniture mécanique côté du moteur / côté liquide : carbure de silicium

CARATTERISTICHE TECNICHE - Technical Features - Caractéristiques Techniques

Motore - Motor - Moteur : B5 IP55	Classe isolamento - Insulating class - Isolement classe : F
Max. temperatura liquido - Max liquid temp. - Max Temperature du liquide: 60°C	
pH Liquido pompato - pH pumped liquid - pH du liquide pompé: 6 - 10	

INSTALLAZIONE ORIZZONTALE - *Horizontal installation - Installation Orizontale*

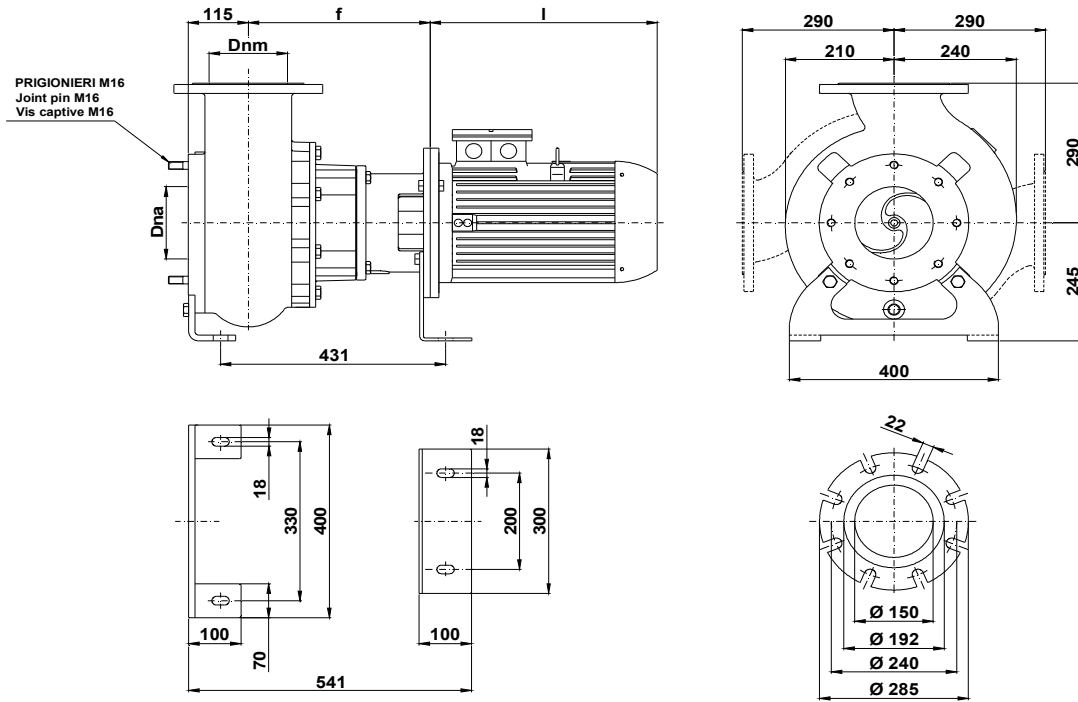

POMPA Pumps Pompe	Dna Dnm	Gr. Motore Motor size Taille du moteur	a	b	c	f	g	h1	h2	l	m1	m2	n1	n2	n3	n4	n7	n8	s1	s2	v	w
KBM 150 -	150	132	115	70	12	348	46	245	290	435	100	100	400	330	300	200	210	240	18	18	544	431

Dimensioni - Size - Dimensions in mm.

INSTALLAZIONE VERTICALE - *Vertical installation - Installation verticale*

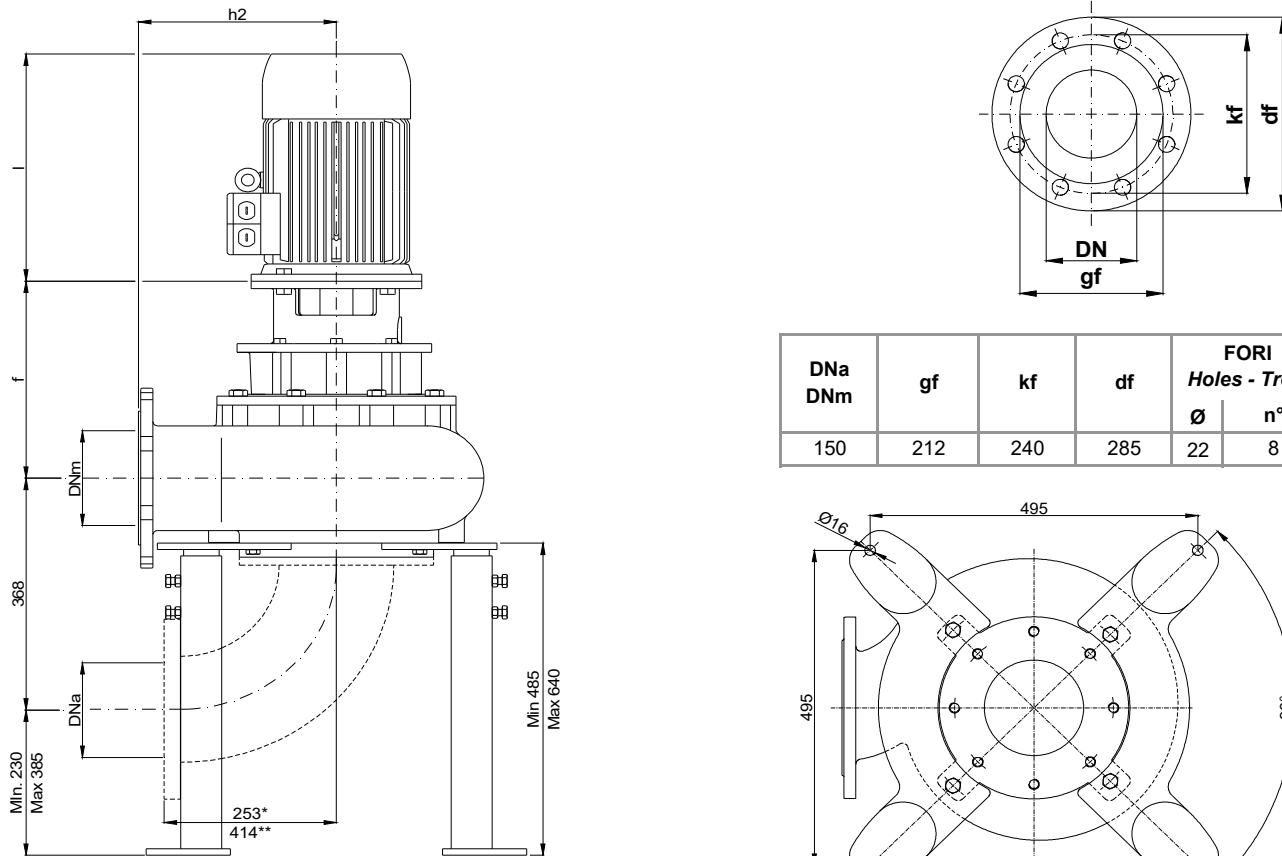

DNa DNm	gf	kf	df	FORI Holes - Trou	
				Ø	n°
150	212	240	285	22	8

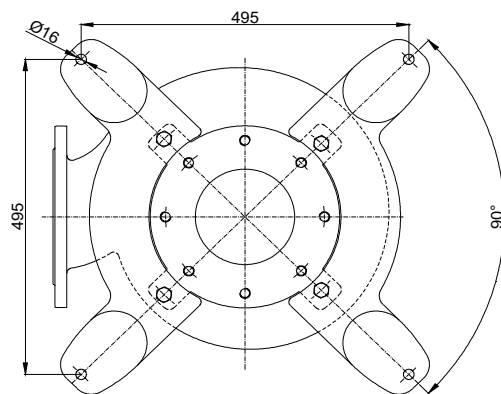

* Curva dima - Curve standard : 3

** Curva dima - Curve standard: 5

KBM 150/4-280-1-17X

Con riserva di variazioni tecniche e costruttive senza preavviso.

With reserve of technical and constructive variations without warning. - Avec réserve de variations techniques et constructives sans préavis.

POMPE ROTOMECH srl - 20063 CERNUSCO SUL NAVIGLIO (MI) - ITALY - Via Ponchielli, 1

Tel.02 9211.0205 - 02 9233.0399 Fax 02 9211.0630 Sito Internet: www.pomperotomec.it E-mail: sales@pomperotomec.it

Elettropompe con motore flangiato per liquidi carichi in camera asciutta
Dry installed sewage electric pumps with flanged motor
Electropompes pour eaux chargées en fosse sèche



N°	CURVA - Curve - Courbe POMPA Pump Pompe	DN	GIRI /Min - RPM - Tours/min.	POTENZA MOTORE Motor rating Puissance moteur	PESO Weight Poids
1	KBM 150-222 A4 L3	150	1450	7,5	195
2	KBM 150-227 A4 L3				

Girante bicanale aperta e diffusore autopulente
Two channel open impeller and self-cleaning diffuser
Roue à 2 canaux ouvert et anneau autonettoyant

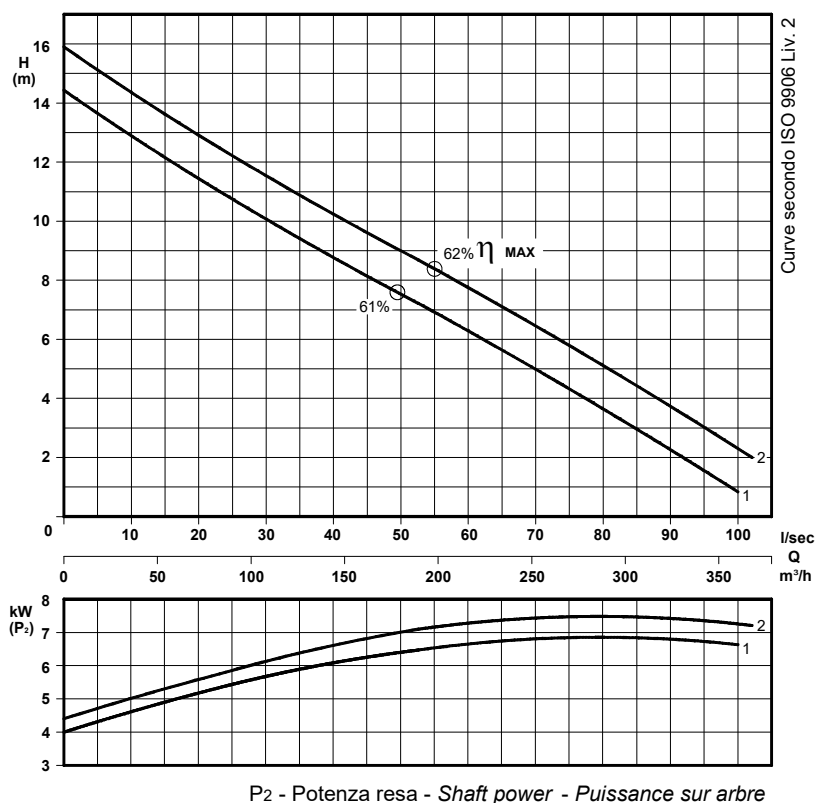
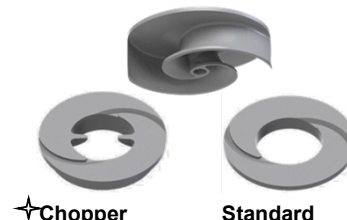

✦ Versione chopper con diffusore a taglienti e girante induriti
Chopper version with cutting diffuser and impeller hardened
Version chopper avec anneau tranchant et roue durci

COSTRUZIONE - Materials - Matériaux	
Fusioni principali - Principal parts - Parts principal	Ghisa - Cast iron - Fonte - GG 25
Girante - Impeller - Roue	Ghisa - Cast iron - Fonte - GS 500
Albero - Shaft - Arbre	AISI 420
Viteria - Screws - Vis	AISI 304

TENUTE MECCANICHE - Mechanical seals - Garniture mécanique
Doppia tenuta meccanica in bagno d'olio - Double mechanical seals in oil bath - Double garniture mécanique en chambre d'huile
Tenuta lato motore / tenuta lato liquido : carburo di silicio
Motor side / liquid side mechanical seal : silicon carbide
Garniture mécanique côté du moteur / côté liquide : carbure de silicium

CARATTERISTICHE TECNICHE - Technical Features - Caractéristiques Techniques	
Motore - Motor - Moteur : B5 IP55	Classe isolamento - Insulating class - Isolement classe : F
Max. temperatura liquido - Max liquid temp. - Max Temperature du liquide: 60°C	
pH Liquido pompato - pH pumped liquid - pH du liquide pompé: 6 - 10	

INSTALLAZIONE ORIZZONTALE - Horizontal installation - Installation Horizontale

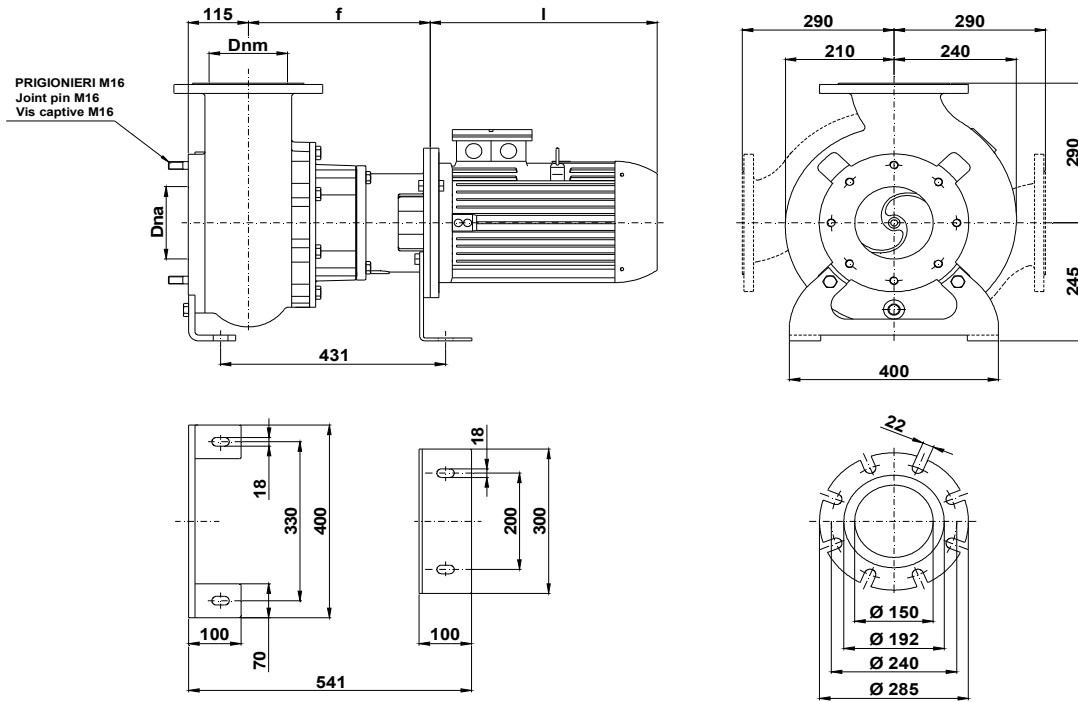

POMPA Pumps Pompe	Dna Dnm	Gr. Motore Motor size Taille du moteur	a	b	c	f	g	h1	h2	l	m1	m2	n1	n2	n3	n4	n7	n8	s1	s2	v	w
KBM 150 -	150	132	115	70	12	348	46	245	290	435	100	100	400	330	300	200	210	240	18	18	544	431

Dimensioni - Size - Dimensions in mm.

INSTALLAZIONE VERTICALE - Vertical installation - Installation verticale

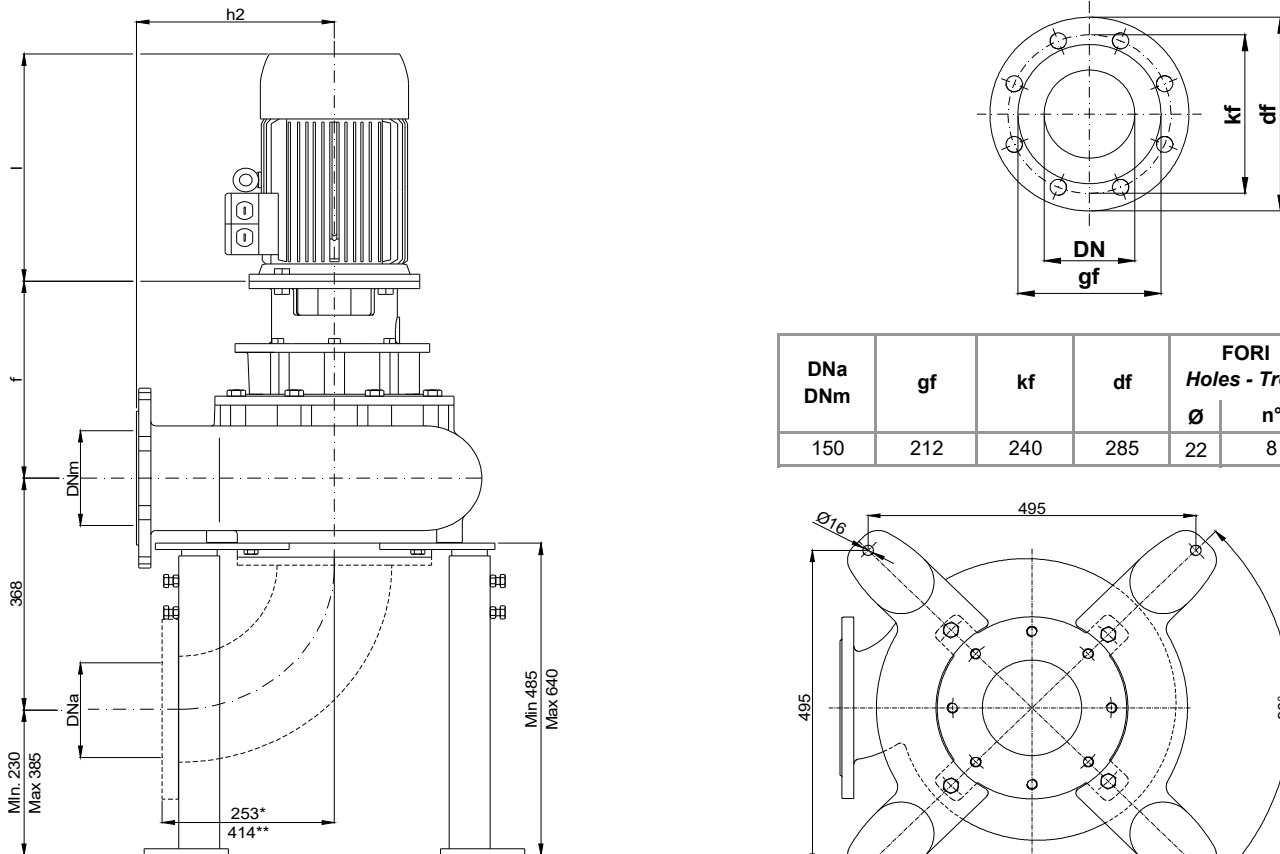

DNa DNm	gf	kf	df	FORI Holes - Trou	
				Ø	n°
150	212	240	285	22	8

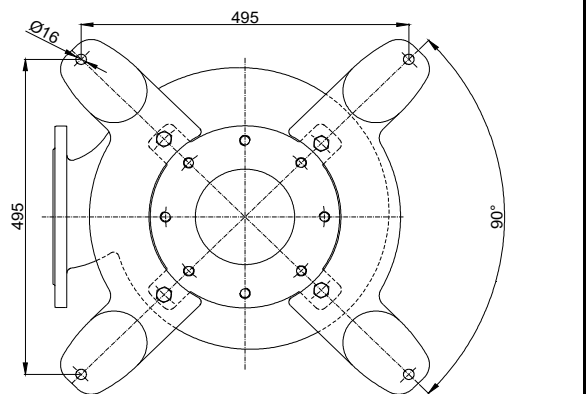

* Curva dima - Curve standard : 3

** Curva dima - Curve standard: 5

KBM 150/4-280-2-17X

Con riserva di variazioni tecniche e costruttive senza preavviso.

With reserve of technical and constructive variations without warning. - Avec réserve de variations techniques et constructives sans préavis.

POMPE ROTOMECH srl - 20063 CERNUSCO SUL NAVIGLIO (MI) - ITALY - Via Ponchielli, 1

Tel.02 9211.0205 - 02 9233.0399 Fax 02 9211.0630 Sito Internet: www.pomperotomec.it E-mail: sales@pomperotomec.it

Elettropompe con motore flangiato per liquidi carichi in camera asciutta
Dry installed sewage electric pumps with flanged motor
Electropompes pour eaux chargées en fosse sèche



CURVA - Curve - Courbe		POMPA Pump Pompe	DN	GIRI /Min - RPM. - Tours/min.	POTENZA MOTORE Motor rating Puissance moteur	PESO Weight Poids
N°					kW	*Kg
1	KBM 150-230 A6 L4	150	1450	11	198	
2	KBM 150-238 A6 L4					

Girante bicanale aperta e diffusore autopulente
Two channel open impeller and self-cleaning diffuser
Roue à 2 canaux ouvert et anneau autonettoyant

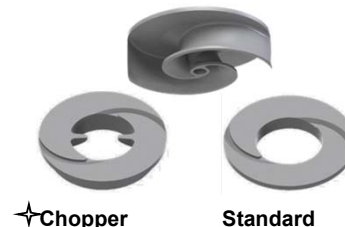

* Peso indicativo

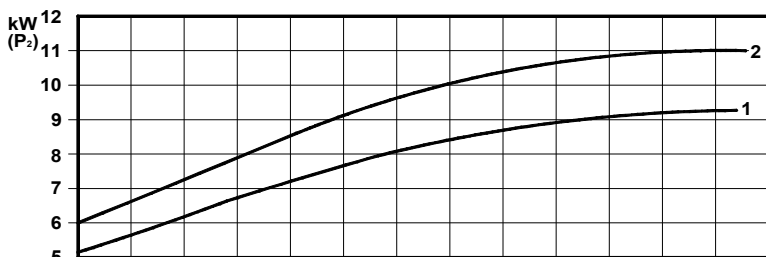
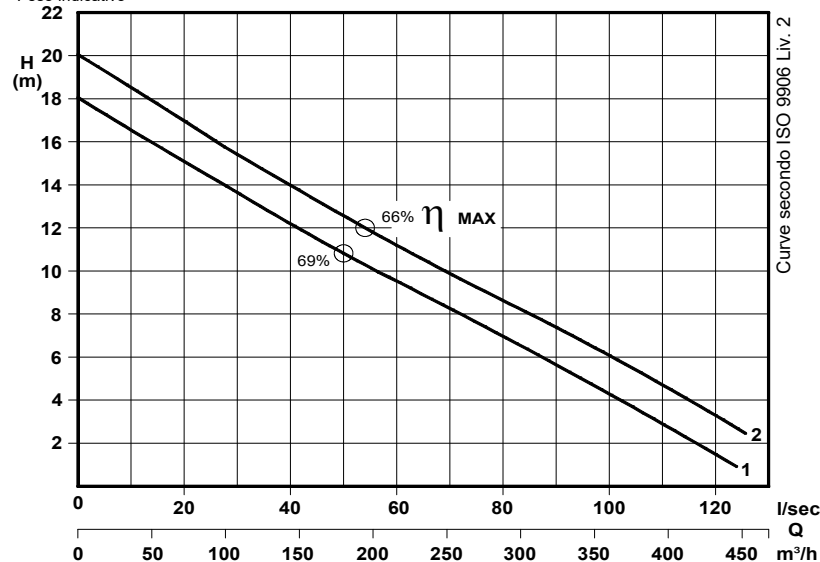

P2 - Potenza resa - Shaft power - Puissance sur arbre

✦ Versione chopper con diffusore a taglienti e girante induriti
 Chopper version with cutting diffuser and impeller hardened
 Version chopper avec anneau tranchant et roue durci

COSTRUZIONE - Materials - Matériaux	
Fusioni principali - Principal parts - Parts principal	Ghisa - Cast iron - Fonte - GG 25
Girante - Impeller - Roue	Ghisa - Cast iron - Fonte - GS 500
Albero - Shaft - Arbre	AISI 420
Viteria - Screws - Vis	AISI 304

TENUTE MECCANICHE - Mechanical seals - Garniture mécanique
Doppia tenuta meccanica in bagno d'olio - Double mechanical seals in oil bath - Double garniture mécanique en chambre d'huile
Tenuta lato motore / tenuta lato liquido : carburo di silicio
Motor side / liquid side mechanical seal : silicon carbide
Garniture mécanique côté du moteur / côté liquide : carbure de silicium

CARATTERISTICHE TECNICHE - Technical Features - Caractéristiques Techniques	
Motore - Motor - Moteur : B5 IP55	Classe isolamento - Insulating class - Isolement classe : F
Max. temperatura liquido - Max liquid temp. - Max Temperature du liquide: 60°C	
pH Liquido pompato - pH pumped liquid - pH du liquide pompé: 6 - 10	

INSTALLAZIONE ORIZZONTALE - *Horizontal installation - Installation Horizontale*

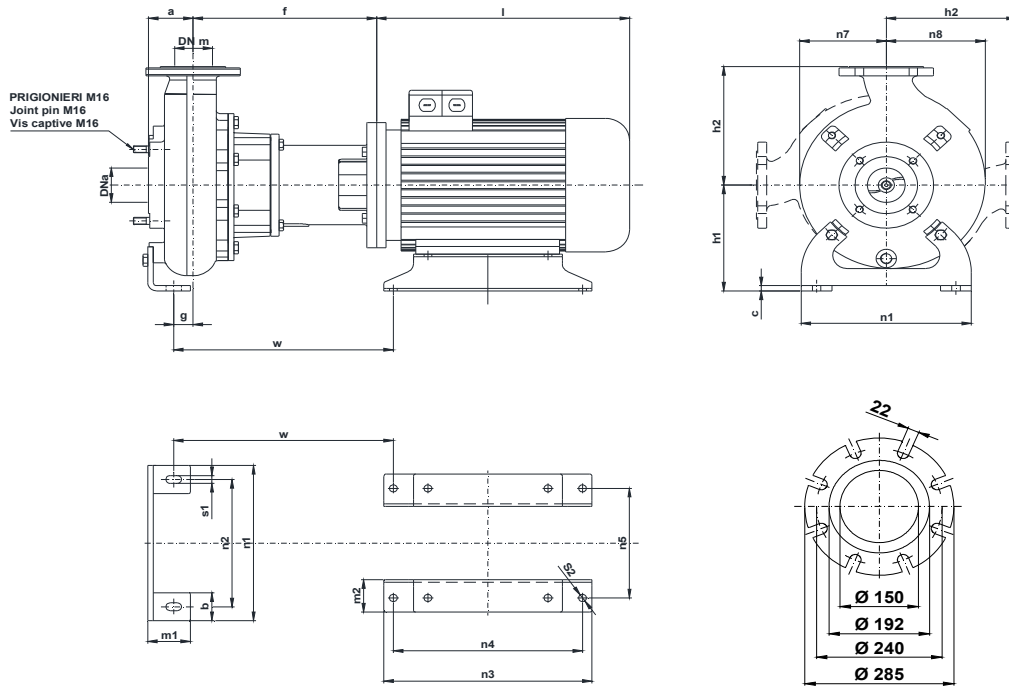

POMPA Pumps Pompe	DNa DNm	Gr. Motore Motor size Taille du moteur	a	b	c	f	g	h1	h2	l	m1	m2	n1	n2	n3	n4	n5	n7	n8	s1	s2	w
KBM 150 -	150	160 M	115	70	12	432	46	245	290	545	100	100	400	330	440	210	254	240	240	18	16,5	490

Dimensioni - Size - Dimensions in mm.

INSTALLAZIONE VERTICALE - *Vertical installation - Installation verticale*

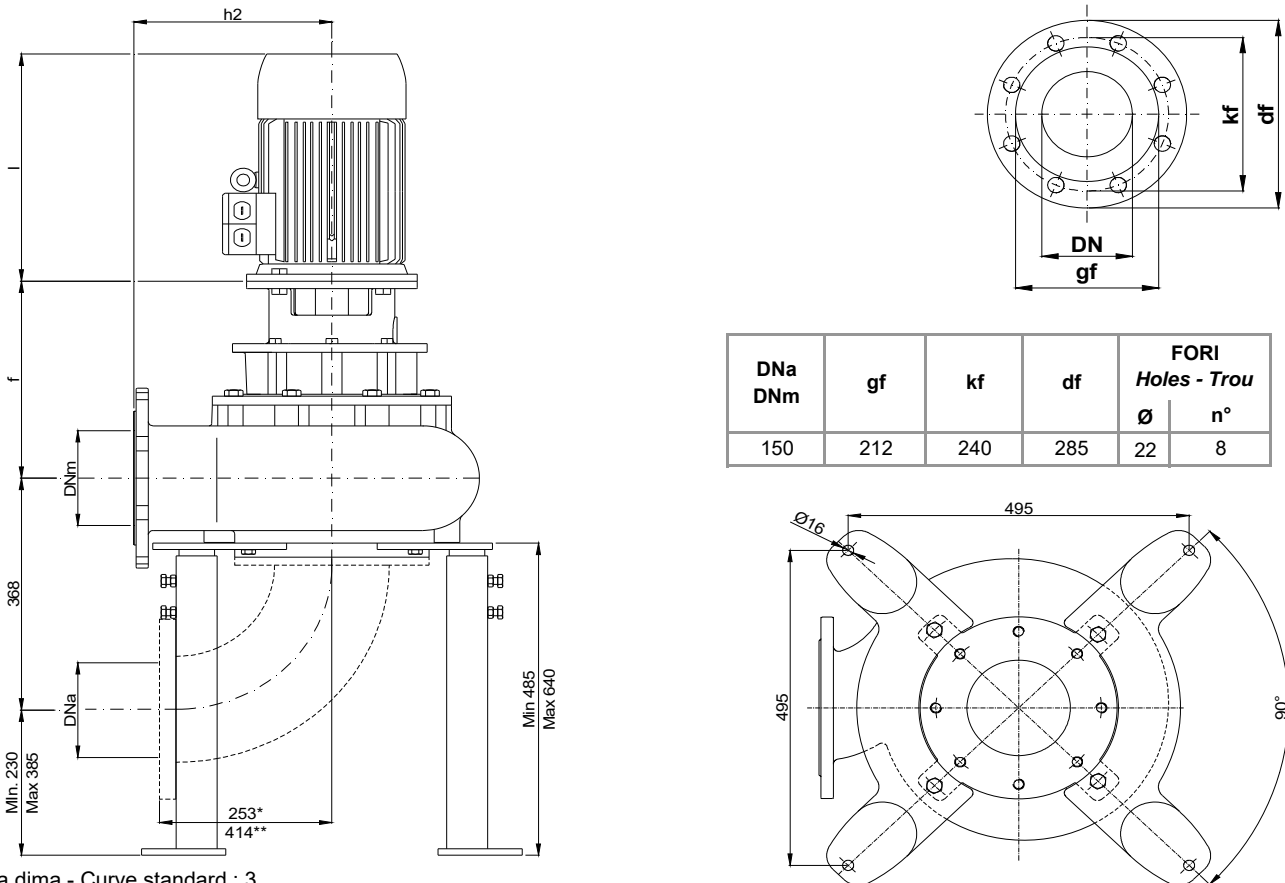

DNa DNm	gf	kf	df	FORI Holes - Trou	
				Ø	n°
150	212	240	285	22	8

* Curva dima - Curve standard : 3

** Curva dima - Curve standard: 5

KBM 150/4-280.3-17X.0

Con riserva di variazioni tecniche e costruttive senza preavviso.

With reserve of technical and constructive variations without warning. - Avec réserve de variations techniques et constructives sans préavis.

POMPE ROTOMECH srl - 20063 CERNUSCO SUL NAVIGLIO (MI) - ITALY - Via Ponchielli, 1

Tel.02 9211.0205 - 02 9233.0399 Fax 02 9211.0630 Sito Internet: www.pomperotomec.it E-mail: sales@pomperotomec.it

Elettropompe con motore flangiato per liquidi carichi in camera asciutta
Dry installed sewage electric pumps with flanged motor
Electropompes pour eaux chargées en fosse sèche



CURVA - Curve - Courbe		POMPA Pump Pompe		DN	GIRI /Min - RPM. - Tours/min.	POTENZA MOTORE Motor rating Puissance moteur	PESO Motore Escluso Weight Without Motor Poids Sans moteur
N°						kW	*Kg
1	KBM 150-250 A6 L4	150	1450	15	285		
2	KBM 150-256 A6 L4						

Girante bicanale aperta e diffusore autopulente
Two channel open impeller and self-cleaning diffuser
Roue à 2 canaux ouvert et anneau autonettoyant



✦ Chopper

Standard

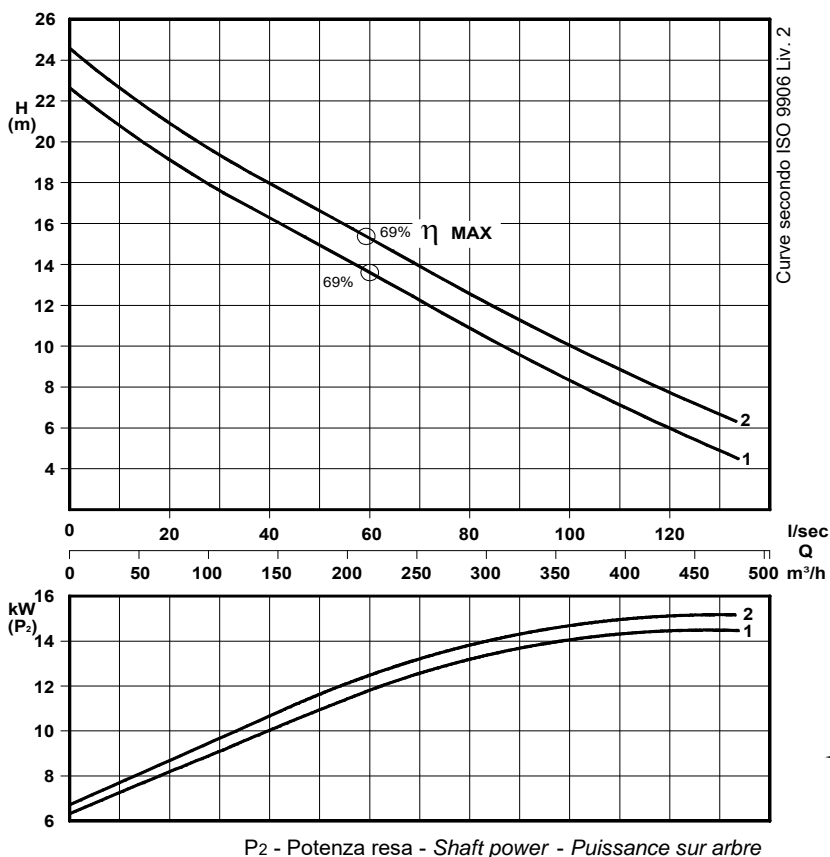

✦ Versione chopper con diffusore a taglienti e girante induriti
 Chopper version with cutting diffuser and impeller hardened
 Version chopper avec anneau tranchant et roue durci

COSTRUZIONE - Materials - Matériaux	
Fusioni principali - Principal parts - Parts principal	Ghisa - Cast iron - Fonte - GG 25
Girante - Impeller - Roue	Ghisa - Cast iron - Fonte - GS 500
Albero - Shaft - Arbre	AISI 420
Viteria - Screws - Vis	AISI 304

TENUTE MECCANICHE - Mechanical seals - Garniture mécanique
Doppia tenuta meccanica in bagno d'olio - Double mechanical seals in oil bath - Double garniture mécanique en chambre d'huile
Tenuta lato motore / tenuta lato liquido : carburo di silicio Motor side / liquid side mechanical seal : silicon carbide Garniture mécanique côté du moteur / côté liquide : carbure de silicium

CARATTERISTICHE TECNICHE - Technical Features - Caractéristiques Techniques	
Motore - Motor - Moteur : B5 IP55	Classe isolamento - Insulating class - Isolement classe : F
Max. temperatura liquido - Max liquid temp. - Max Temperature du liquide: 60°C	
pH Liquido pompato - pH pumped liquid - pH du liquide pompé: 6 - 10	

INSTALLAZIONE ORIZZONTALE - *Horizontal installation - Installation Horizontale*

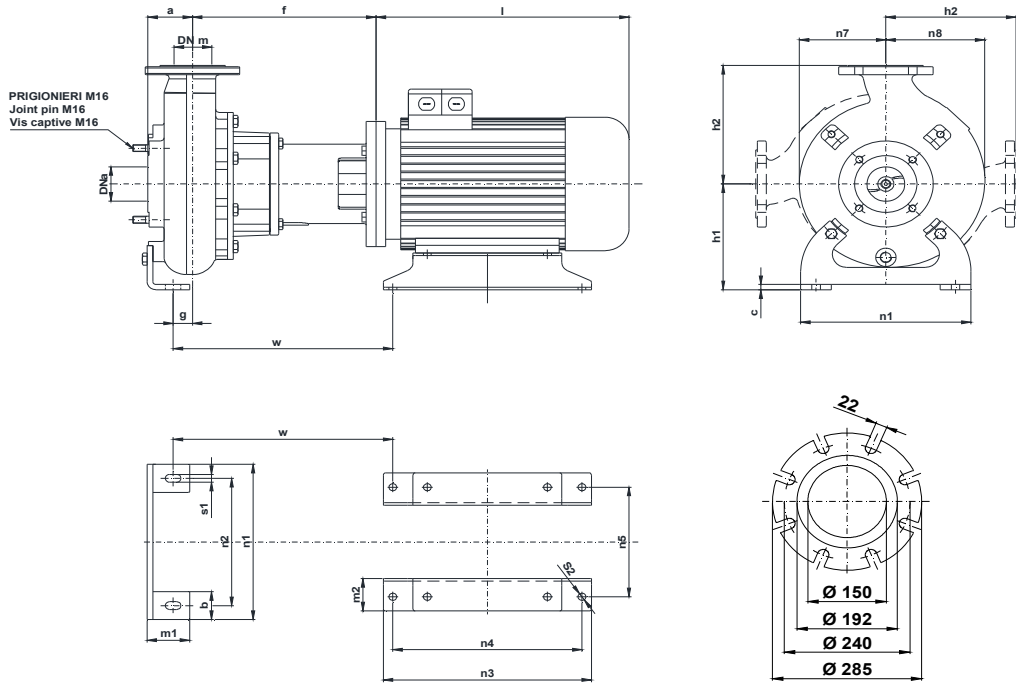

POMPA Pumps Pompe	DNa DNm	Gr. Motore Motor size Taille du moteur	a	b	c	f	g	h1	h2	l	m1	m2	n1	n2	n3	n4	n5	n7	n8	s1	s2	w
KBM 150 -	150	160 L	115	70	12	432	46	245	290	570	100	100	400	330	440	254	254	240	240	18	16,5	513

Dimensioni - Size - Dimensions in mm.

INSTALLAZIONE VERTICALE - *Vertical installation - Installation verticale*

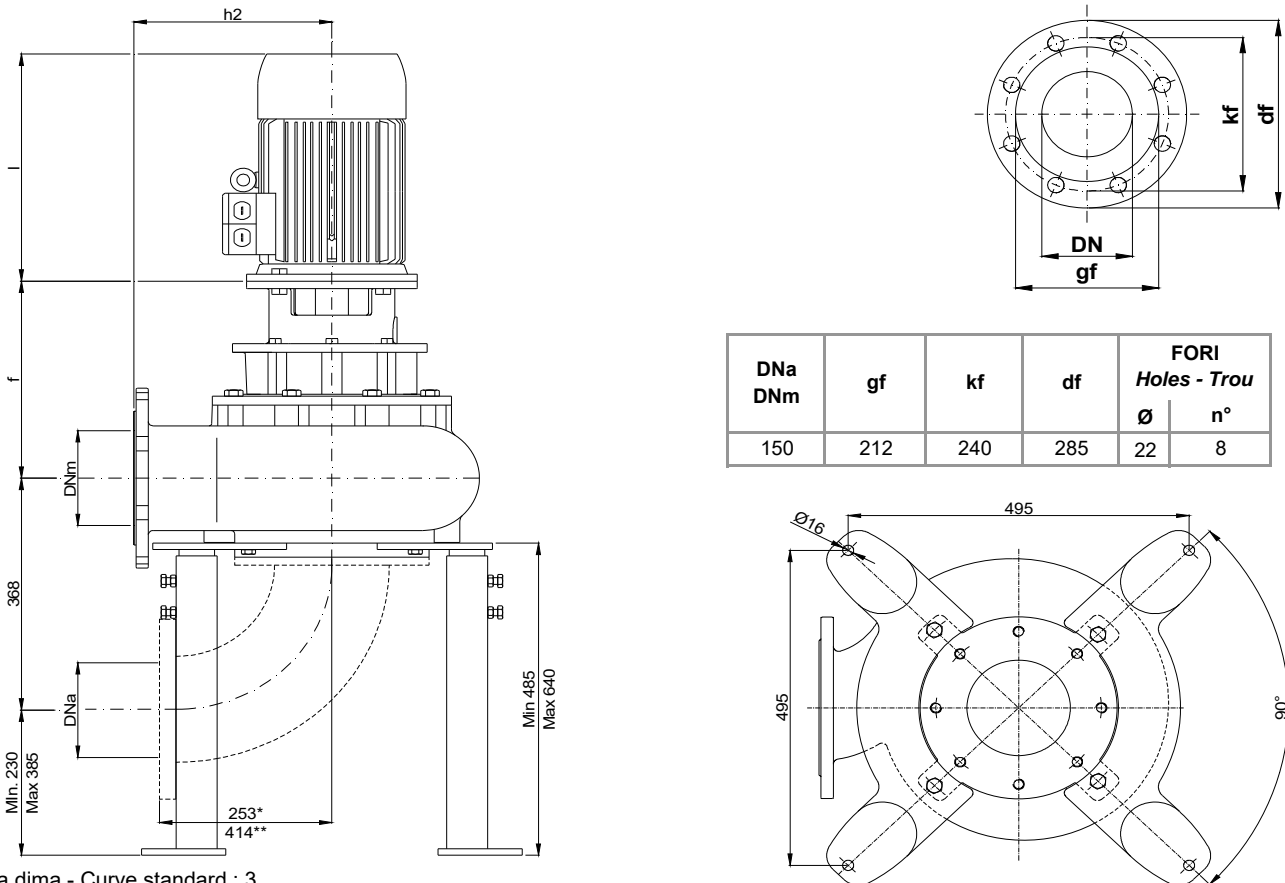

DNa DNm	gf	kf	df	FORI Holes - Trou	
				Ø	n°
150	212	240	285	22	8

* Curva dima - Curve standard : 3

** Curva dima - Curve standard: 5

KBM 150/4-280.4-17X.0

Con riserva di variazioni tecniche e costruttive senza preavviso.

With reserve of technical and constructive variations without warning. - Avec réserve de variations techniques et constructives sans préavis.

POMPE ROTOMECH srl - 20063 CERNUSCO SUL NAVIGLIO (MI) - ITALY - Via Ponchielli, 1

Tel.02 9211.0205 - 02 9233.0399 Fax 02 9211.0630 Sito Internet: www.pomperotomec.it E-mail: sales@pomperotomec.it

Elettropompe con motore flangiato per liquidi carichi in camera asciutta
Dry installed sewage electric pumps with flanged motor
Electropompes pour eaux chargées en fosse sèche



CURVA - Curve - Courbe		POMPA Pump Pompe		DN	GIRI /Min - RPM. - Tours/min.	POTENZA MOTORE Motor rating Puissance moteur	PESO Weight Poids
N°						kW	*Kg
1	KBM 150-265 A7 L4	150	1450	18,5	330		

Girante bicanale aperta e diffusore autopulente
Two channel open impeller and self-cleaning diffuser
Roue à 2 canaux ouvert et anneau autonettoyant

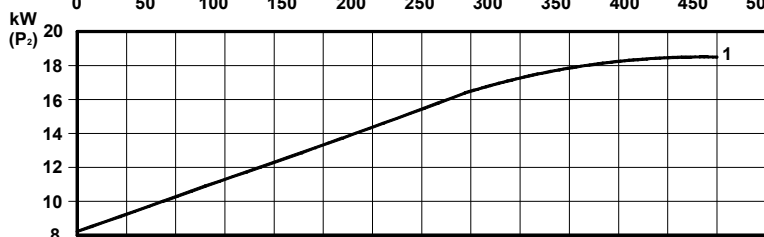
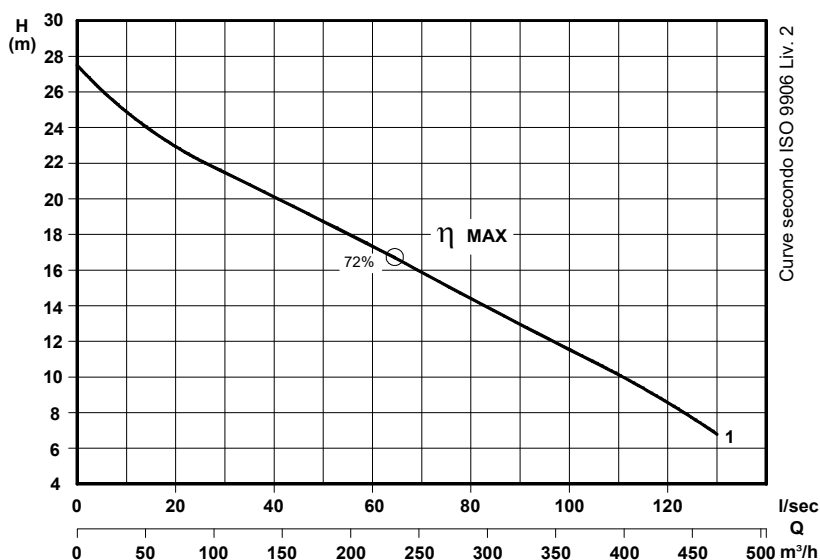
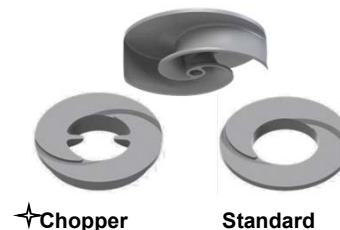

P2 - Potenza resa - Shaft power - Puissance sur arbre

✦ Versione chopper con diffusore a taglienti e girante induriti
Chopper version with cutting diffuser and impeller hardened
Version chopper avec anneau tranchant et roue durci

COSTRUZIONE - Materials - Matériaux

Fusioni principali - Principal parts - Parts principal	Ghisa - Cast iron - Fonte - GG 25
Girante - Impeller - Roue	Ghisa - Cast iron - Fonte - GS 500
Albero - Shaft - Arbre	AISI 420
Viteria - Screws - Vis	AISI 304

TENUTE MECCANICHE - Mechanical seals - Garniture mécanique

Doppia tenuta meccanica in bagno d'olio - Double mechanical seals in oil bath - Double garniture mécanique en chambre d'huile
 Tenuta lato motore / tenuta lato liquido : carburo di silicio
Motor side / liquid side mechanical seal : silicon carbide
Garniture mécanique côté du moteur / côté liquide : carbure de silicium

CARATTERISTICHE TECNICHE - Technical Features - Caractéristiques Techniques

Motore - Motor - Moteur : B5 IP55	Classe isolamento - Insulating class - Isolement classe : F
Max. temperatura liquido - Max liquid temp. - Max Temperature du liquide: 60°C	
pH Liquido pompato - pH pumped liquid - pH du liquide pompé: 6 - 10	

INSTALLAZIONE ORIZZONTALE - *Horizontal installation - Installation Horizontale*

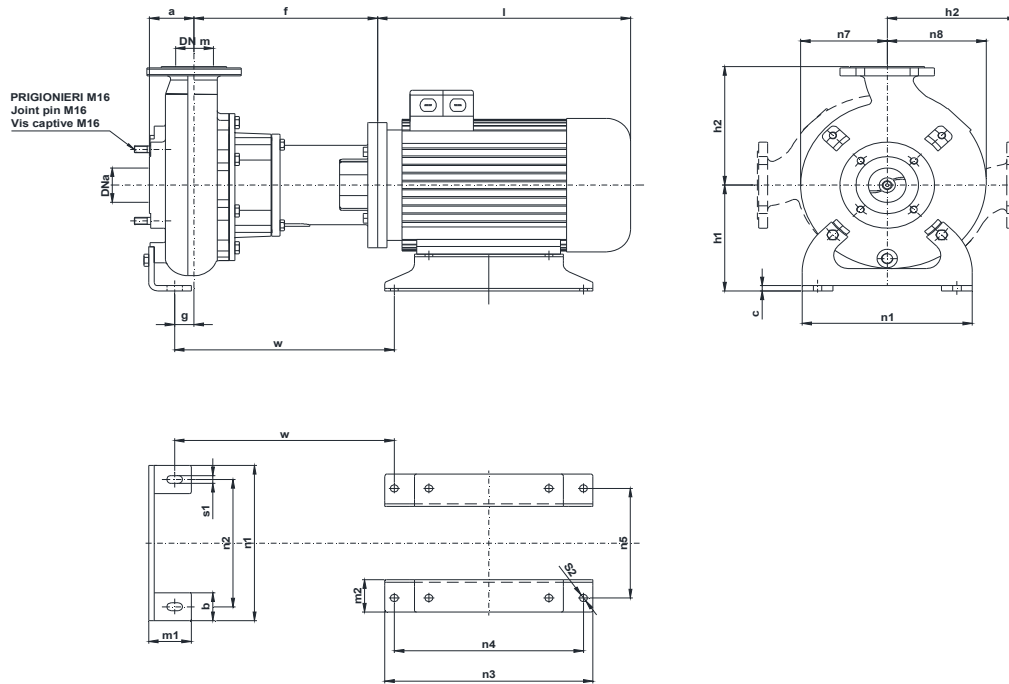

POMPA Pumps Pompe	DNa DNm	Gr. Motore Motor size Taille du moteur	a	b	c	f	g	h1	h2	l	m1	m2	n1	n2	n3	n4	n5	n7	n8	s1	s2	w
KBM 150 -	150	180 M	115	70	12	432	46	245	290	575	100	100	400	330	440	241	279	210	240	18	16,5	520

Dimensioni - Size - Dimensions in mm.

INSTALLAZIONE VERTICALE - *Vertical installation - Installation verticale*

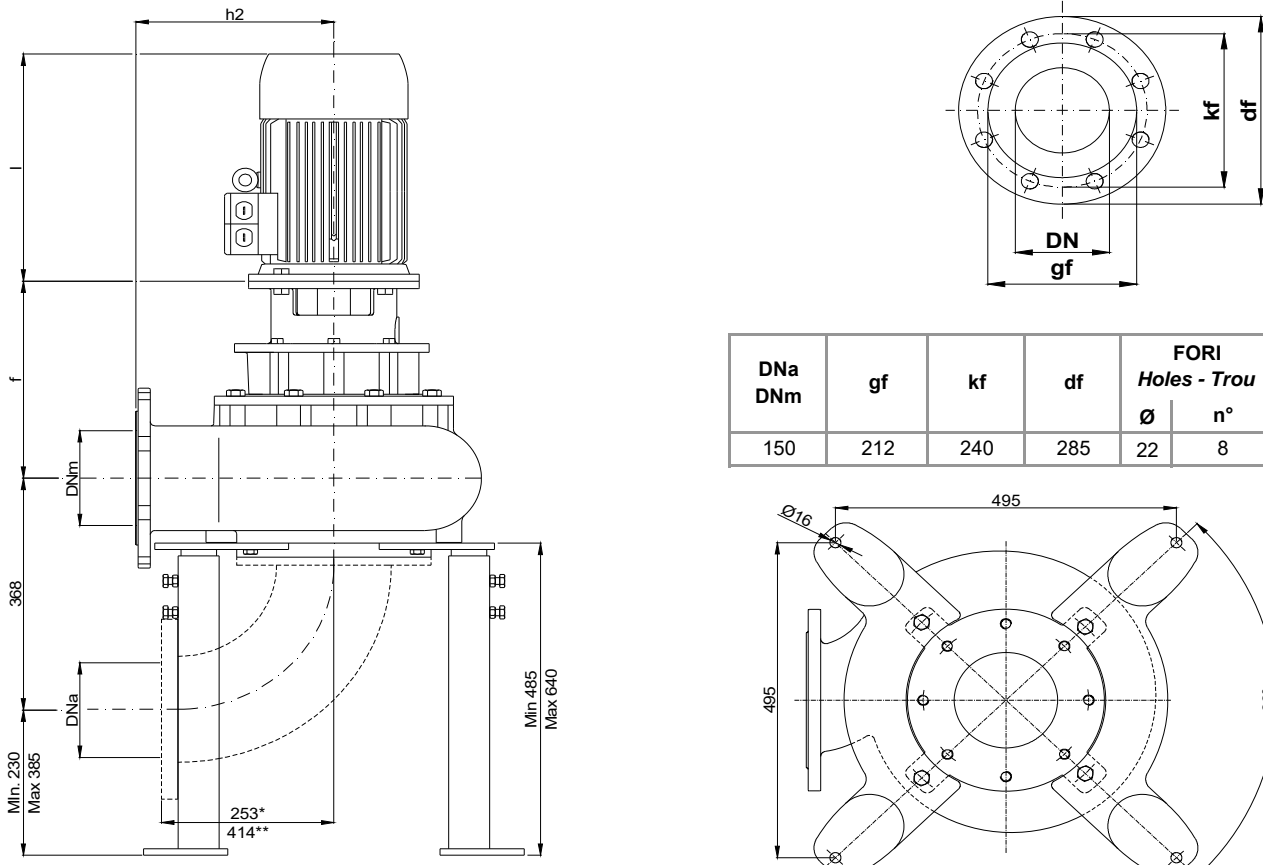

DNa DNm	gf	kf	df	FORI Holes - Trou	
				Ø	n°
150	212	240	285	22	8

* Curva dima - Curve standard : 3

** Curva dima - Curve standard: 5

KBM 150/4-280.5-17X.0

Con riserva di variazioni tecniche e costruttive senza preavviso.

With reserve of technical and constructive variations without warning. - Avec réserve de variations techniques et constructives sans préavis.

POMPE ROTOMECH srl - 20063 CERNUSCO SUL NAVIGLIO (MI) - ITALY - Via Ponchielli, 1

Tel.02 9211.0205 - 02 9233.0399 Fax 02 9211.0630 Sito Internet: www.pomperotomec.it E-mail: sales@pomperotomec.it