

AJ10G409T30KA

SOTR

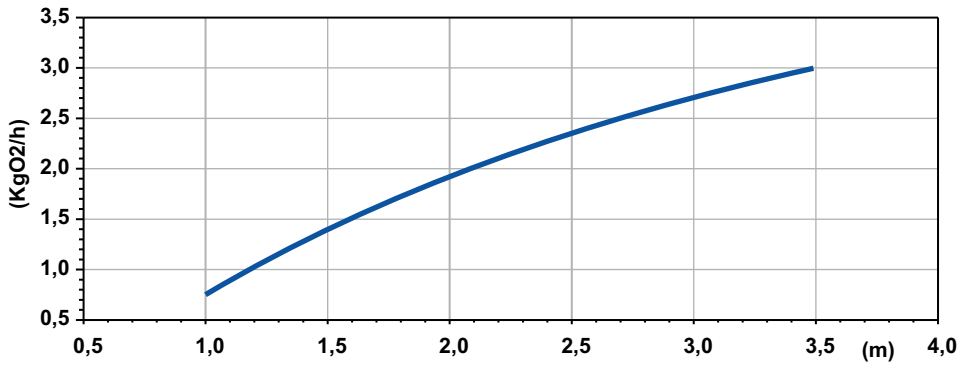

Potenza Assorbita - Absorbed Power P1
 Puissance Absorbée - Leistungsaufnahme P1
 Potencia Absorbida - Поглощенная мощность P1

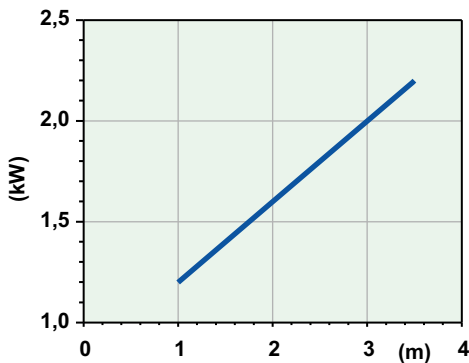

Aria Aspirata - Suction Air
 L'air D'aspiration - Saugluft
 Succión De Aire - Аспирированный воздух
 Nm^3 a 0 °C, RH 0 %, p = 101,3 kPa

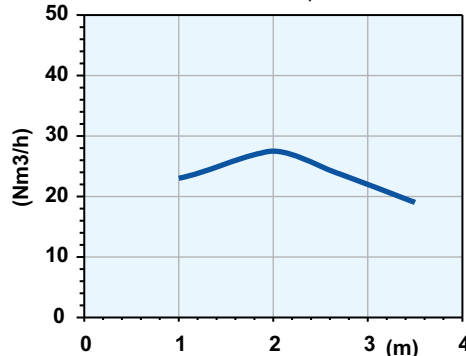

Battente idraulico - Hydraulic head - Charge hydraulique - Hydraulischen Belastung
 Cabezal hidráulico - Гидронапор

Code	5009650
Type	AJ10G409T30KA
Suction (mm)	1"1/4
Free passage (mm)	30x22
Immersion depth (m)	1-3,5
Motor type	M409T-2,3-400/50NN-IE3
Power supply	3ph 400V-50Hz
MOTOR Rotation speed R.P.M.	1382
Rated power P2 (kW)	2,3
Rated current I (A)	4,4
Starting current Is (A)	19,8
Weight (Kg)	62
Cable	H07RN/F 4G2,5
SOTR OBTAINED FOLLOWING STANDARD UNI EN 12255-15:2004	

Dimensioni - Dimensions - Dimensions - Abmessungen - Dimensiones - Габариты (mm)

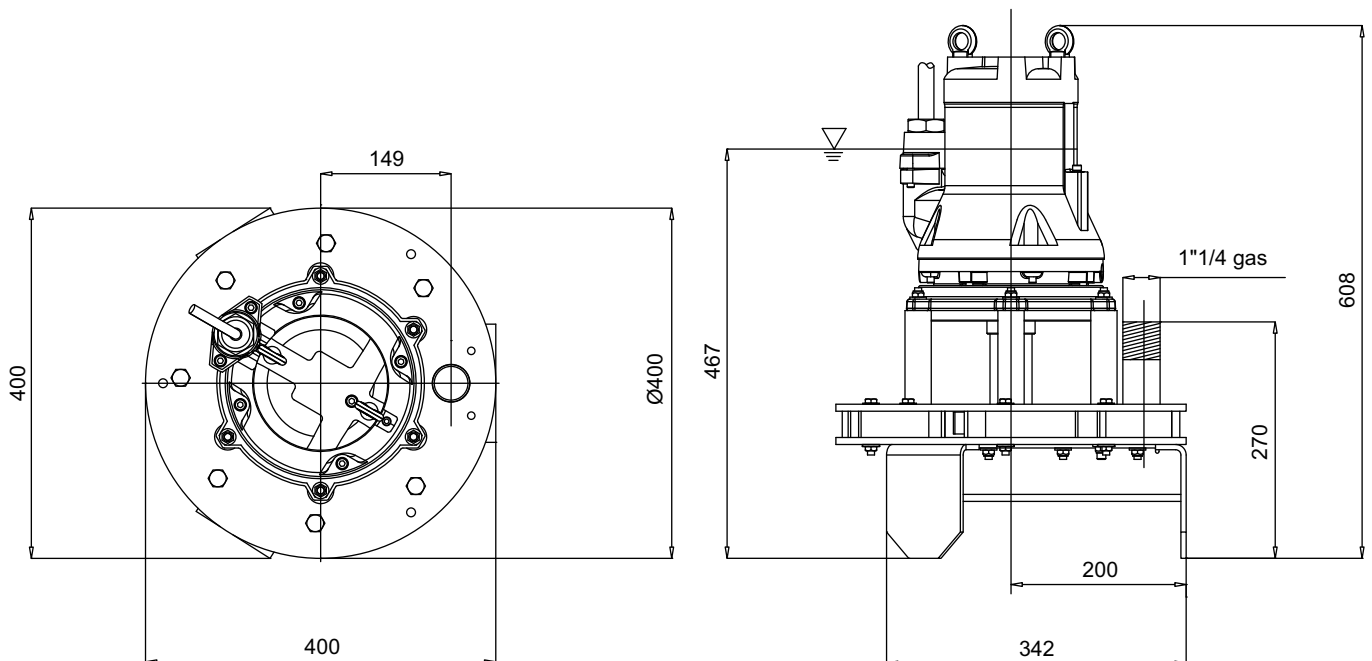

LIVELLO MINIMO DI SOMMERGIBILITÀ - MINIMUM SUBMERSIBLE LEVEL - NIVEAU MINIMUM D'IMMERSION
 MINDESTWASSERSTAND - NIVEL SUMERGIBLE MÍNIMO - МИНИМАЛЬНАЯ ГЛУБИНА ПОГРУЖЕНИЯ