

GNASHER

230V submersible grinder pumps for waste water and sewage

These heavy duty 230/1/50 grinder pumps have been designed for arduous waste water and sewage type applications. They feature G250 cast iron body/volute; G250+Ni impeller; stainless steel grinder mechanism (AISI 440), shaft and fixings; and H07RN/F neoprene cable. Models G1M to G5M have Nitrile O-rings and lip seal and silicon carbide/carbide mechanical seal arrangement. Supplied with either threaded horizontal flange (1½" or 2") or 2" BSPF elbow discharge. All 230V single phase models can be supplied for either manual or auto (float switch) operation. An IP55 control box houses On/Off illuminated switch, start and run capacitors, thermal overload and reset. Guiderail options on all models.

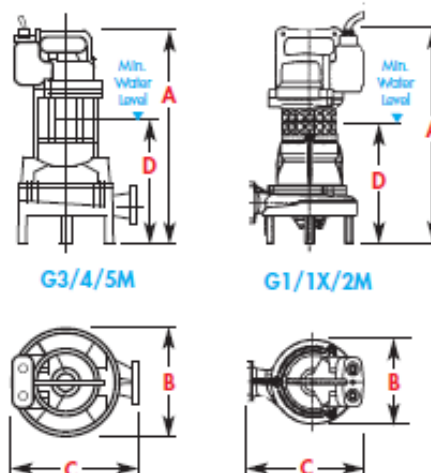
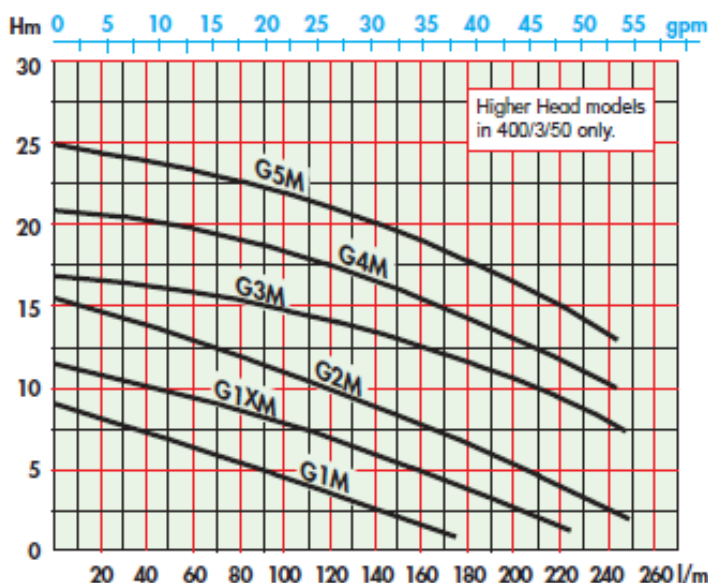

TECHNICAL DATA									
MODEL	NOM kW	NOM. AMP	DIMENSIONS mm				Flange/Elbow	SOLIDS mm dia	WEIGHT Kg
			A	B	C	D			
G1M (G272M3T3-J6AD1/AC1)	1.1	6.6	472	208	253	266	1½" or 2"F / 2"F	6	30
G1XM (G272M3T2-J6AD1/AC1)	1.1	6.6	472	208	253	266	1½" or 2"F / 2"F	6	30
G2M (G272M3T1-J6AD1/AC1)	1.1	6.6	472	208	253	266	1½" or 2"F / 2"F	6	30
G3M (G271M6T3-J6AD1/AC1)	1.1	6.6	460	224	268	246	1½" or 2"F / 2"F	6	40
G4M (G271M6T2-J6AD1/AC1)	1.5	9.0	460	224	268	246	1½" or 2"F / 2"F	6	40
G5M (G271M6T1-J6AD1/AC1)	1.9	11.4	460	224	268	246	1½" or 2"F / 2"F	6	40

POLYPUMP LIMITED

...pumping solutions