

Self-priming Pump

Etaprime B

Type Series Booklet



Legal information/Copyright

Type Series Booklet Etaprime B

All rights reserved. The contents provided herein must neither be distributed, copied, reproduced, edited or processed for any other purpose, nor otherwise transmitted, published or made available to a third party without the manufacturer's express written consent.

Subject to technical modification without prior notice.

© KSB Aktiengesellschaft, Frankenthal 17/10/2017

Contents

Self-priming Pump in Close-coupled Design..... 4

- Volute Casing Pumps 4
- Etaprime B 4
 - Main applications..... 4
 - Fluids handled 4
 - Operating data..... 4
 - Design details 4
 - Designation 5
 - Materials..... 6
 - Product benefits 6
 - Certifications 6
 - Overview of product features / selection tables 7
 - Selection Information 9
 - Pressure limits..... 10
 - Technical data 10
 - Selection charts 11
 - Dimensions and connections 15
 - Flange designs..... 19
 - Interchangeability of Etaprime B and Etaprime L pump components 20
 - Scope of supply 20
 - General assembly drawings with list of components 21

Self-priming Pump in Close-coupled Design

Volute Casing Pumps

Etaprime B

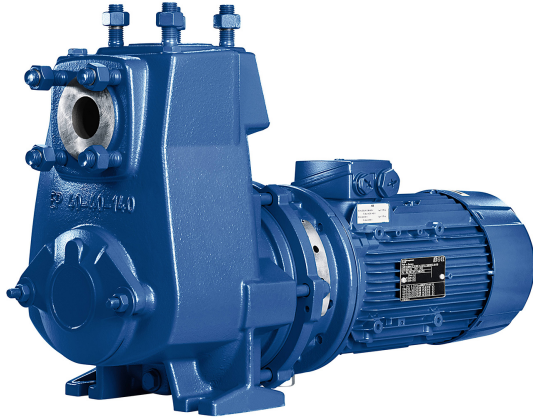

Main applications

- Spray irrigation systems
- Service water supply systems
- Drainage
- Drainage systems
- Fire-fighting systems
- Lowering groundwater levels
- Domestic water supply
- Air-conditioning systems
- Cooling circuits
- Swimming pools
- Water supply systems

Fluids handled

- Drinking water
- Swimming pool water¹⁾
- Fire-fighting water
- Seawater
- River water
- Lake water
- Groundwater
- Brackish water
- Condensate
- Brine
- Oil

- Service water
- Cleaning agents
- Cooling water

Operating data

Operating properties

Characteristic		Value	
		50 Hz	60 Hz
Flow rate	Q [m ³ /h]	≤ 130	≤ 150
	Q [l/s]	≤ 36	≤ 42
Head	H [m]	≤ 70	≤ 100
Fluid temperature	T [°C]	≥ -30	≥ -30
		≤ +90	≤ +90
Operating pressure	p [bar]	≤ 10	≤ 10
Static head	H _{Geo} [m]	≤ 9	≤ 9

Design details

Design

- Volute casing pump
- Back pull-out design (from size 40-40-140)
- Horizontal installation
- Self-priming
- Single-stage
- Single-entry
- Pump and motor connected by a stub shaft

Pump casing

- Radially split volute casing
- Volute casing with integrally cast pump feet (from pump size 40-40-140)

Drive

- KSB IEC frame standardised IE3 motor (from 0.75 kW)
- Type of construction B34 ≤ 1.1 kW
- Type of construction V1 1.1 to 4 kW
- Type of construction V15 > 4 kW
- 230/400 V up to 2.2 kW and 400/690 V from 3 kW
- Enclosure IP55
- Thermal class F
- 3 PTC thermistors

Shaft seal

- The shaft is fitted with a replaceable shaft sleeve in the shaft seal area (from pump size 40-40-140).
- Single mechanical seals and double mechanical seals to EN 12756

Impeller type

- Open multi-vane impeller

1) Swimming pool water (0.4 to 1.4 mg/l free chlorine, max. 0.6 mg/l combined chlorine, pH 6.9 to 7.7, water hardness 10 to 30 °dH, max. salt content 7 g/l)

Designation

Designation example

Position																																
1	2	3	4	5	6	7	8	9	10	11	12	13	14	15	16	17	18	19	20	21	22	23	24	25	26	27	28	29	30	31	32	
E	T	P	B	0	8	0	-	0	8	0	-	2	0	0		G	C	X	I	1	0	D	3	0	1	8	5	2				B
See name plate and data sheet																								See data sheet								

Designation key

Position	Code	Description
1-4	Pump type	
	ETPB	Etaprime bloc
5-16	Pump size, e.g.	
	080	Nominal suction nozzle diameter [mm]
	080	Nominal discharge nozzle diameter [mm]
	200	Nominal impeller diameter [mm]
17	Pump casing material	
	G	Cast iron EN-GJL-250 / A48CL35
	C	Stainless steel 1.4408 / A743CF8M
18	Impeller material	
	G	Cast iron EN-GJL-250
	C	Stainless steel 1.4408
19	Design	
	_2)	Standard
	X	Non-standard (BT3D, BT3)
20	Shaft seal type	
	I	Single mechanical seal, internal circulation (conical seal chamber only)
	D	Double mechanical seal in back-to-back arrangement
	T	Double mechanical seal in tandem arrangement with internal circulation
21-22	Seal code, single mechanical seal	
	01	Q1Q1VGG
	08	AQ1VGG ³⁾
	09	U3U3VGG
	10	Q1Q1X4GG
	11	BQ1EGG
	70	Q12Q1M1GG
23	Scope of supply	
	D	Pump with motor
24	Shaft unit	
	1	Shaft unit 17
	2	Shaft unit 25
	3	Shaft unit 35
25-28	Motor size	
29	Number of motor poles	
30-31	Explosion protection	
	ex	With explosion-proof motor
	_2)	Without explosion-proof motor
32	Product generation	
	B	Etaprime Global Pump

2) Blank

3) For shaft unit 17: BQVGG

Materials

A1 = default material variant
A2 = optional material variant

Part No.	Description	Material	Material variant		
			G	GC	C
102	Volute casing	Grey cast iron EN-GJL-250	A1	A1	-
		Stainless steel 1.4408	-	-	A1
161	Casing cover	Grey cast iron EN-GJL-250	A1	A1	-
		Stainless steel 1.4408	-	-	A1
210	Shaft for shaft units 25 and 35	Tempered steel C45+N	A1	A1	-
		Stainless steel 1.4571	A2	A2	A1
	Shaft for shaft unit 17	Stainless steel 1.4571	A1	A1	A1
230	Impeller	Grey cast iron EN-GJL-250	A1	-	-
		Stainless steel 1.4408	-	A1	A1
341	Drive lantern for shaft units 25 and 35	Grey cast iron EN-GJL-250	A1	A1	A1
	Drive lantern for shaft unit 17	Grey cast iron EN-GJL-250	A1	A1	-
		Stainless steel 1.4408	-	-	A1
412	O-ring	EPDM 80 peroxide ⁴⁾	A1	A1	A1
523	Shaft sleeve (not for shaft unit 17)	Stainless steel 1.4571	A1	A1	A1

Product benefits

- Maintenance-free mechanical seal ensures operating reliability
- Easy to dismantle due to back pull-out design; no need to remove the pump casing from the piping
- Good suction performance, self-priming up to 9 m suction lift, also suitable for applications with relatively poor inlet conditions (i.e. low or negative inlet pressure) and for handling fluids with entrained gas.
- Optimised hydraulic components for high efficiency help reduce energy consumption

Certifications

Overview

Label	Effective in:	Comment
	All countries	Certified quality management to ISO 9001

4) FKM 80 on request

Overview of product features / selection tables
Overview of fluids handled

Table of fluids handled and associated material combinations
X = recommended variant

Fluid handled	Temperature	Materials			Shaft seal						Comments	
		Casing/impeller			Mechanical seal							
		Grey cast iron/ grey cast iron	Grey cast iron/ Cr-Ni-Mo cast steel	CrNiMo cast steel/ CrNiMo cast steel	Q1Q1VGG	AQ1VGG ⁵⁾ BQVGG ⁶⁾	U3U3VGG	Q1Q1X4GG	BQ1EGG ⁵⁾	Q12Q1M1GG		
[°C]	G	GC	C	01	08	09	10	11	70			
Water												
Industrial waste water	-	-	-	-	-	-	-	-	-	-	-	Analysis of fluid handled required
Ammonia water (ammonia solution), percentage ≤ 10 %	≤ 40	X	-	-	-	-	-	-	X	-	-	Tandem seal Q1Q1EGG required. Quench liquid: use suitable water.
Brackish water	≤ 25	-	-	X	-	-	-	X	-	-	-	-
Fire-fighting water ⁷⁾	≤ 60	-	X	-	-	-	-	X	-	-	-	-
Condensate ⁵⁾	≤ 90	X	-	-	-	-	-	-	X	-	-	-
Condensate, not conditioned	≤ 90	-	-	X	-	-	-	-	X	-	-	-
Cooling water (without antifreeze) ⁷⁾	≤ 60	X	-	X ⁸⁾	-	-	-	X	-	-	-	-
Cooling water pH ≥ 7.5 (with antifreeze) ⁷⁾⁹⁾	≥ -30 to ≤ 90	X	-	X	-	-	-	-	X	-	-	-
Slightly contaminated water ⁷⁾	≤ 60	X	-	-	-	-	-	X	-	-	-	-
Seawater	≤ 25	-	-	X	-	-	-	X	-	-	-	-
Surface water ⁷⁾	≤ 40	X	-	-	-	X	-	-	-	-	-	Analysis of fluid handled required
Pure water ¹⁰⁾	≤ 60	X	-	-	-	-	-	-	X	-	-	-
Raw water ⁷⁾	≤ 60	X	-	-	-	-	-	X	-	-	-	-
Swimming pool water (fresh water) ⁷⁾	≤ 60	X	-	-	-	-	-	X	-	-	-	Also applies to requirements as per DIN 19643
Dam water ⁷⁾	≤ 60	X	-	-	-	-	-	X	-	-	-	If solids are contained, contact KSB.
Drinking water	≤ 60	-	-	X	-	-	-	-	-	-	-	-
Partly desalinated water ⁵⁾	≤ 90	X	-	-	-	-	-	-	X	-	-	-
Fully desalinated water	≤ 90	-	-	X	-	-	-	-	X	-	-	Requirements for ultra-pure water cannot be met.
Fully desalinated water as boiler feed water ⁵⁾	≤ 90	X	-	-	-	-	-	-	X	-	-	-
Refrigerants, cooling brines												
Cooling brine; inorganic, pH > 7.5, inhibited	≥ -30 to ≤ 25	X	-	-	-	-	-	-	X	-	-	-
Water with antifreeze, pH > 7.5 ⁷⁾⁹⁾	≥ -30 to ≤ 90	X	-	-	-	-	-	-	X	-	-	-
Oils/emulsions												
Drilling/grinding emulsion	≤ 60	X	-	-	-	-	X	-	-	-	-	-
Oil/water emulsion	≤ 60	X	-	-	-	-	X	-	-	-	-	-
Cleaning agent												

5) Treatment to VdTÜV 1466; additional requirement: O₂ ≤ 0.02 mg/l

6) Only applies to shaft unit 17.

7) General criteria for results of water analysis: pH ≥ 7; chloride content (Cl) ≤ 250 mg/kg. Chlorine (Cl₂) ≤ 0.6 mg/kg.

8) For open circuit

9) Antifreeze on ethylene glycol basis with inhibitors. Content: 20 % to 50 % (e.g. Antifrogen N), p ≤ 10 bar

10) No ultra-pure water! Conductivity at 25 °C: ≤ 800 µS/cm

Fluid handled	Temperature	Materials			Shaft seal						Comments
		Casing/impeller			Mechanical seal						
		Grey cast iron/ grey cast iron	Grey cast iron/ Cr-Ni-Mo cast steel	CrNiMo cast steel/ CrNiMo cast steel	Q1Q1VGG	AQ1VGG ⁵⁾ BQVGG ⁶⁾	U3U3VGG	Q1Q1X4GG	BQ1EGG ⁵⁾	Q12Q1M1GG	
[°C]	G	GC	C	01	08	09	10	11	70		
Lyes for bottle rinsers ¹¹⁾	≤ 90	X	-	-	-	-	-	X	-	-	EPDM only if oil-free
Acids											
Acetic acid, percentage ≤ 10 %	≤ 60	-	-	X	-	-	-	-	X	-	-
Alum, potassium aluminium sulphate up to 3 %	≤ 80	-	-	X	X	-	-	-	-	-	-

Overview of type series

Available sizes and designs

Size	Shaft unit	Etaprime L		Etaprime B	
		G	GC, C	G	GC, C
032-032-100	17	I/T	-	I/T	-
032-032-120	17	I/T	I/T	I/T	I/T
040-040-110	17	I/T	I/T	I/T	I/T
040-040-140	25	I/D/T	I/D/T	I/D/T	I/D/T
050-050-130	25	I/D/T	I/D/T	I/D/T	I/D/T
050-050-160	25	I/D/T	I/D/T	I/D/T	I/D/T
065-065-150	25	I/D/T	I/D/T	I/D/T	I/D/T
065-065-180	35	I/D/T	I/D/T	I/D/T	I/D/T
080-080-170	35	I/D/T	I/D/T	I/D/T	I/D/T
080-080-190	35	I/D/T	-	I/D/T	-
080-080-200	35	I/D/T	I/D/T	I/D/T	I/D/T
100-100-240.1	35	I/D/T	-	I/D/T	-
100-100-240	35	I/D/T	-	-	-
125-125-260	35	I/D/T	-	-	-

- I: Single mechanical seal (standard design)
- D: Available with double mechanical seal in back-to-back arrangement
- T: Available with double mechanical seal in tandem arrangement

11) With 2 % sodium hydroxide

Selection Information

Priming time

For a 1-metre horizontal length of the suction line and DN suction line = DN pump, the priming times are as follows.

When handling gaseous fluids, fluids which tend to froth or water with a temperature $T > 60\text{ }^{\circ}\text{C}$, the pump will not be self-priming. In such cases, a check valve must be installed in the suction line.

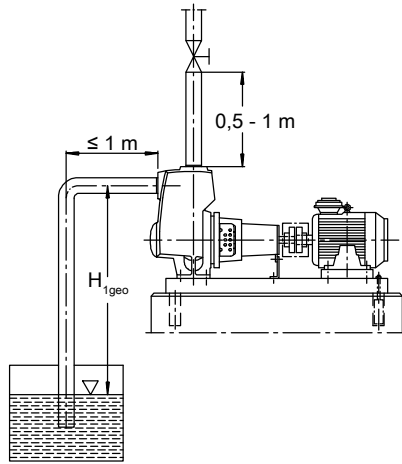

Fig. 1: Distances of suction line and discharge line

Priming time in [seconds] at a static suction lift H_{1geo} of ... m, depending on the speed, 50 Hz

Size	Shaft unit	n = 2900 rpm						n = 1450 rpm							
		2 m	4 m	5 m	6 m	7 m	8 m	1 m	2 m	3 m	4 m	5 m	6 m	7 m	8 m
025-025-100	17	40	145	415	-	-	-	130	-	-	-	-	-	-	-
032-032-120	17	30	90	135	190	255	360	100	210	-	-	-	-	-	-
040-040-110	17	60	100	215	420	-	-	120	-	-	-	-	-	-	-
040-040-140	25	30	70	125	220	355	600	130	-	-	-	-	-	-	-
050-050-130	25	50	120	195	260	345	440	210	410	-	-	-	-	-	-
050-050-160	25	30	70	105	170	265	430	210	430	-	-	-	-	-	-
065-065-150	25	60	120	165	260	375	570	190	350	540	-	-	-	-	-
065-065-180	35	30	50	75	100	145	200	90	140	220	370	-	-	-	-
080-080-170	35	50	100	135	180	225	310	110	180	280	480	-	-	-	-
080-080-190	35	40	70	105	160	185	240	100	110	200	310	-	-	-	-
080-080-200	35	30	50	75	105	155	200	70	110	190	270	320	420	-	-
100-100-240.1	35	30	70	95	120	150	190	130	150	220	300	440	-	-	-
100-100-240	35	35	70	85	110	160	-	110	160	270	480	-	-	-	-
125-125-260	35	35	80	105	130	160	190	60	70	110	160	200	330	430	610

Priming time in [seconds] at a static suction lift H_{1geo} of ... m, depending on the speed, 60 Hz

Size	Shaft unit	n = 3500 rpm						n = 1750 rpm							
		2 m	4 m	5 m	6 m	7 m	8 m	1 m	2 m	3 m	4 m	5 m	6 m	7 m	8 m
025-025-100	17	30	85	135	-	-	-	70	170	-	-	-	-	-	-
032-032-120	17	20	60	105	140	175	250	80	150	260	-	-	-	-	-
040-040-110	17	30	85	125	200	265	470	90	180	-	-	-	-	-	-
040-040-140	25	25	50	85	120	145	230	80	150	200	-	-	-	-	-
050-050-130	25	30	90	140	190	245	300	130	240	380	-	-	-	-	-
050-050-160	25	25	55	75	150	215	280	130	260	480	-	-	-	-	-
065-065-150	25	40	80	125	170	225	370	140	260	350	430	-	-	-	-
065-065-180	35	20	40	65	90	105	150	80	110	170	220	330	-	-	-
080-080-170	35	30	80	105	130	165	220	90	130	200	320	480	-	-	-
080-080-190	35	30	55	75	100	125	160	80	100	130	160	210	390	-	-
080-080-200	35	25	40	55	80	125	160	60	100	160	230	280	350	-	-
100-100-240.1	35	25	60	85	115	145	180	90	110	140	210	260	400	-	-
100-100-240	35	25	70	85	100	155	360	80	100	140	200	300	-	-	-
125-125-260	35	-	-	-	-	-	-	50	60	80	115	170	220	300	400

Pressure limits

Size	Max. discharge-side operating pressure ¹²⁾	Test pressure ¹³⁾
	[bar]	[bar]
All	10,0	15,0

Technical data

Motors

Motor size	Number of motor poles	IEC frame size	50 Hz		60 Hz	
			P	I	P	I
			[kW]	[A] ¹⁴⁾	[kW]	[A]
0005	4	80	0,6	1,4	0,6	1,4
0011	2	80	1,1	2,6	1,3	2,6
0015	4	90L	1,5	3,4	1,7	3,4
0022	2	90L	2,2	4,6	2,5	4,6
0022	4	100L	2,2	4,9	2,5	4,9
0030	4	100L	3,0	6,3	3,4	6,3
0030	2	100L	3,0	6,3	3,4	6,3
0040	4	112M	4,0	8,3	4,6	8,3
0040	2	112M	4,0	8,3	4,6	8,3
0055	2	132S	5,5	11,0	6,3	11,0
0075	2	132S	7,5	14,6	8,6	14,6
0110	2	160M	11,0	20,7	12,6	20,7
0150	2	160M	15,0	28,0	17,3	28,0
0185	2	160L	18,5	33,0	21,3	33,0
0220	2	180M	22,0	40,0	24,5	40,0
0300	2	200L	30,0	54,0	34,5	54,0

12) The sum of inlet pressure and shut-off head must not exceed the values indicated.

13) The casing components are checked for leakage by means of internal pressure tests with water.

14) The currents indicated are for orientation only. For the exact currents refer to the motor name plate.

Selection charts

Etaprime L / Etaprime B, n = 2900 rpm (* also available in stainless steel material variant)

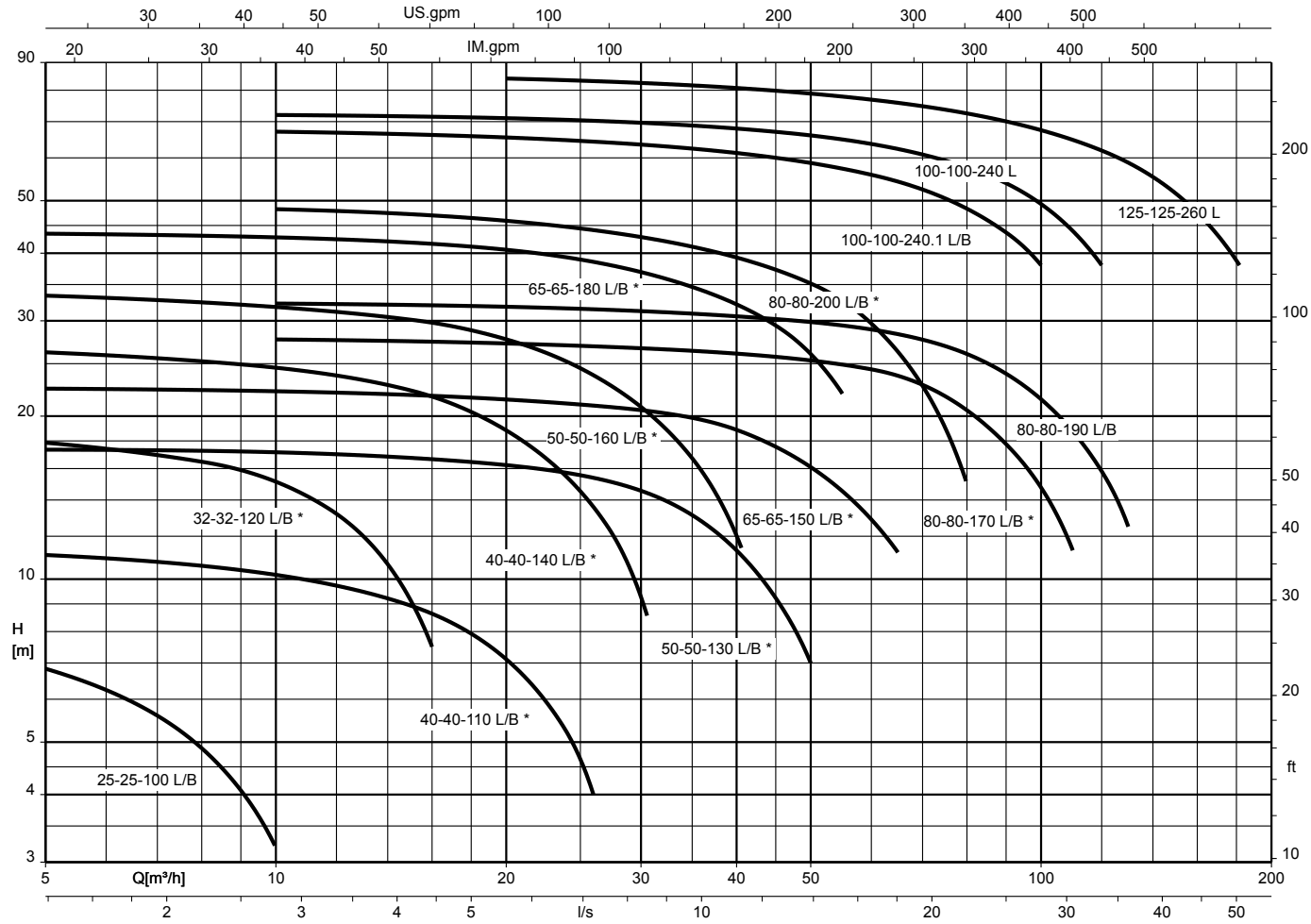

Etaprime L / Etaprime B, n = 1450 rpm (* also available in stainless steel material variant)

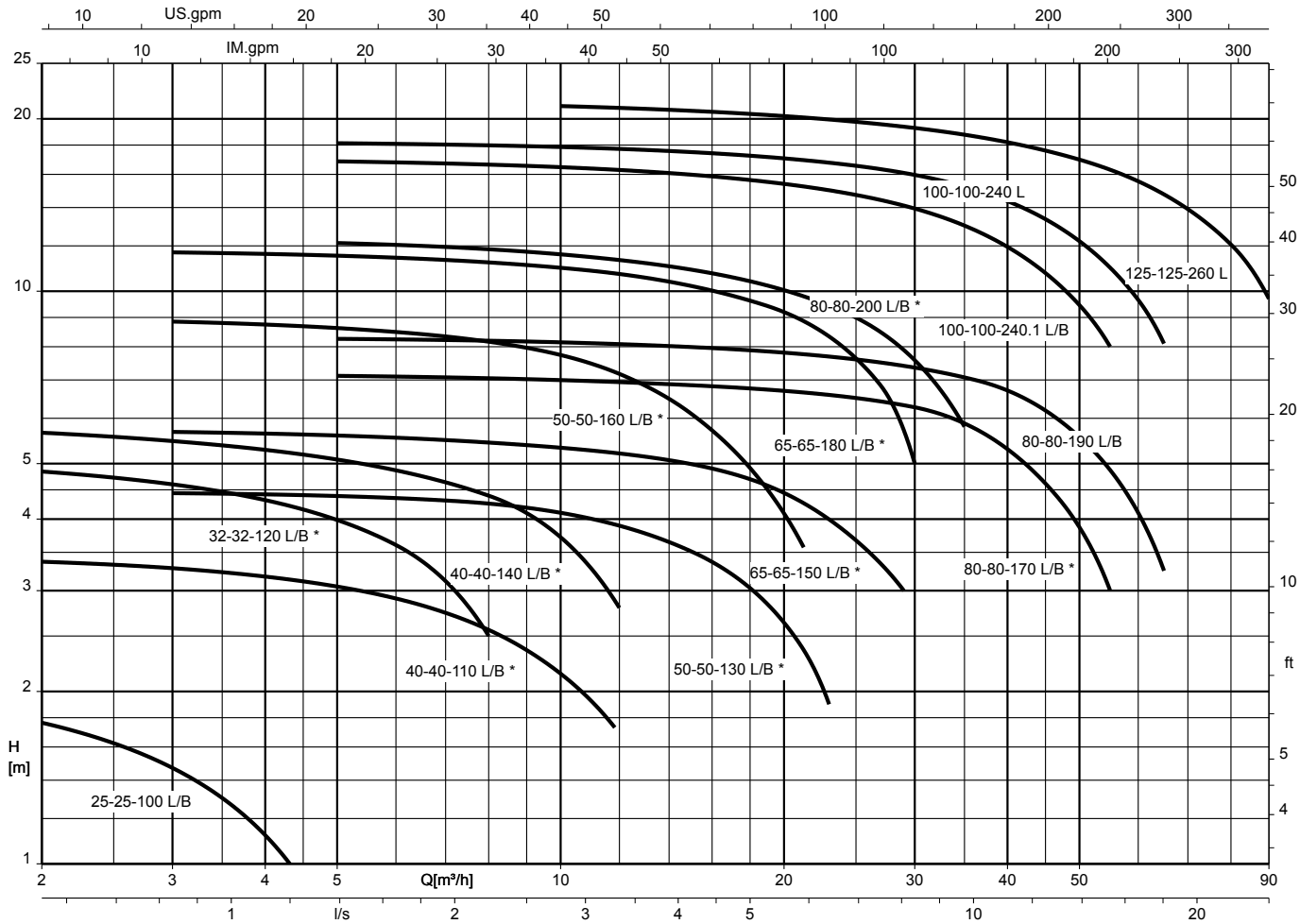

Etaprime L / Etaprime B, n = 3500 rpm (* also available in stainless steel material variant)

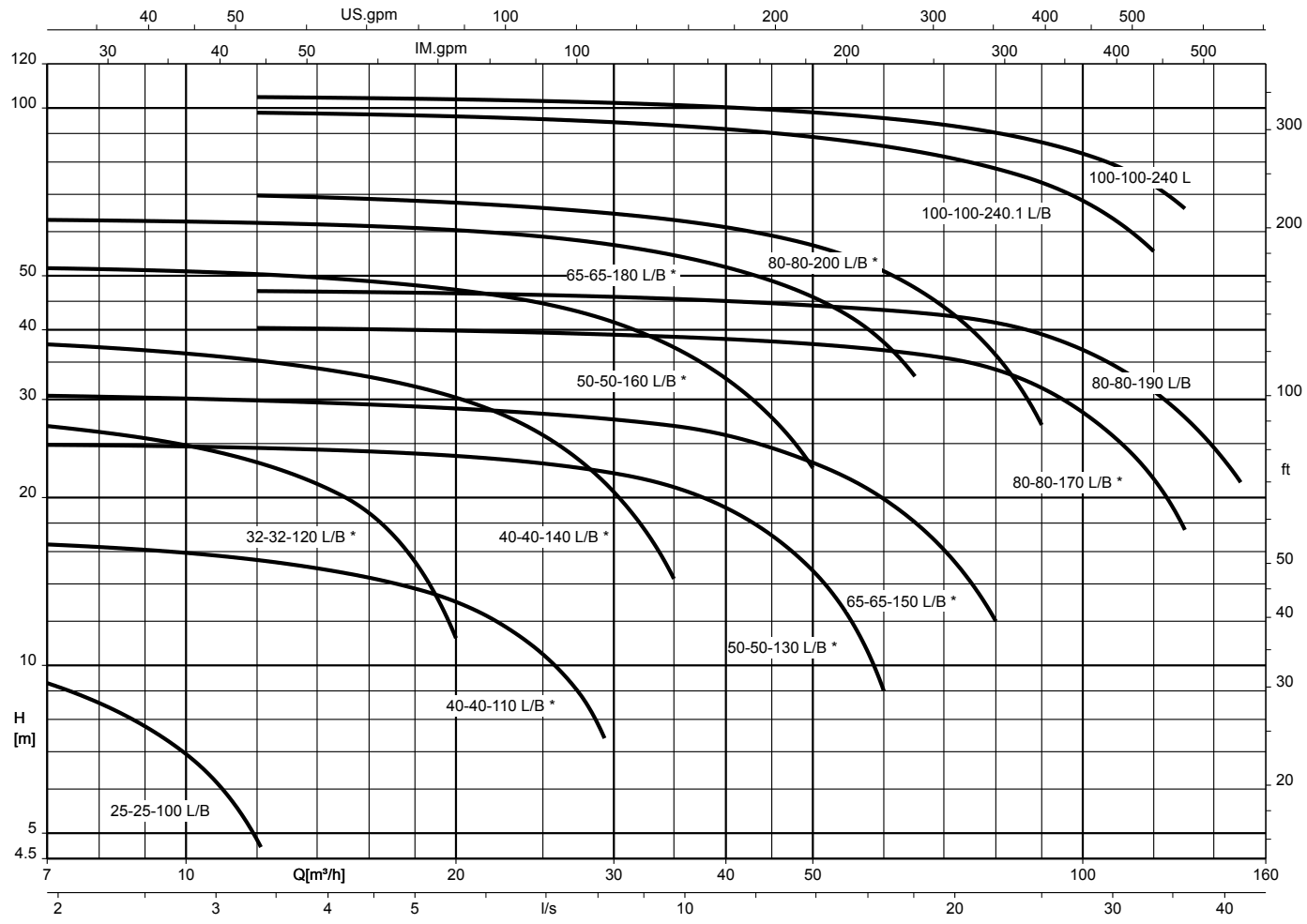

Etaprime L / Etaprime B, n = 1750 rpm (* also available in stainless steel material variant)

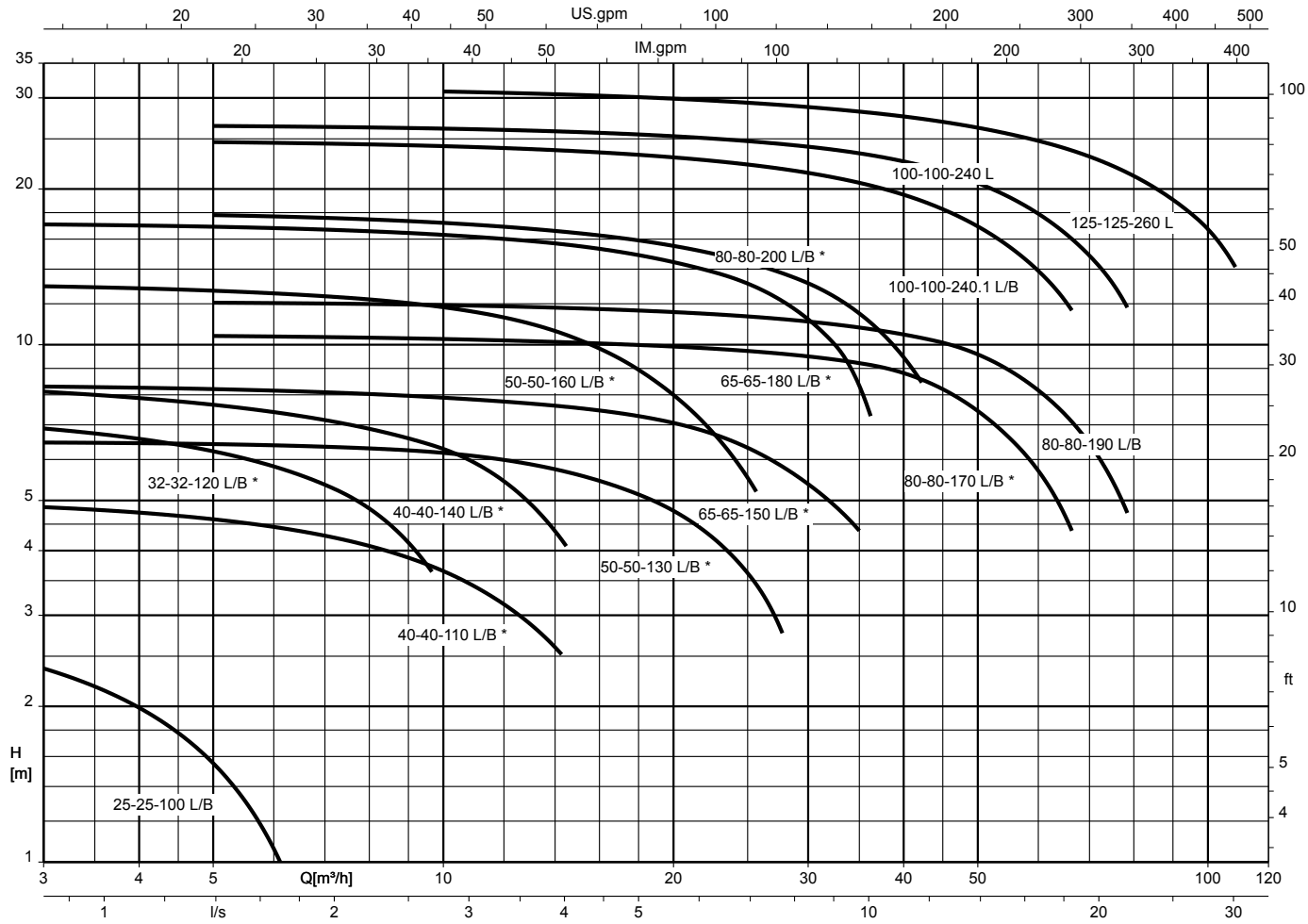

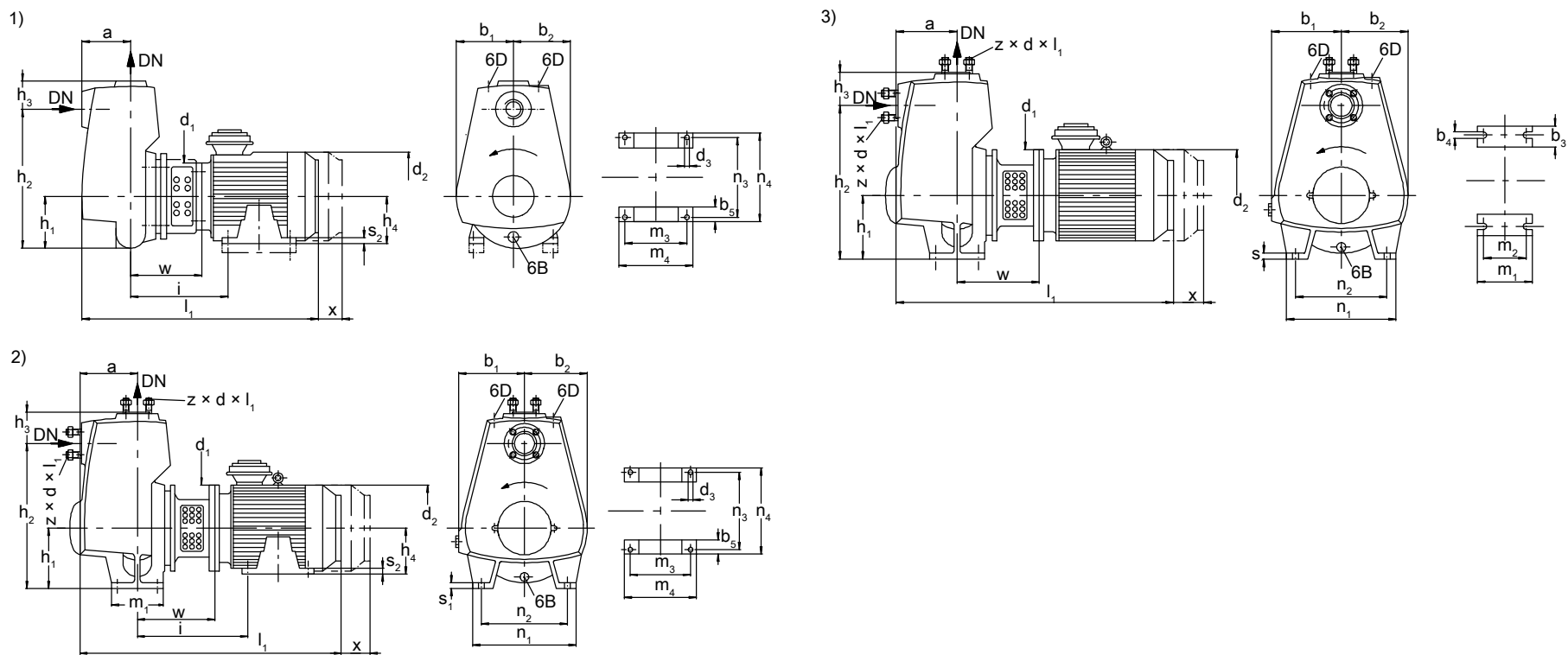
Dimensions and connections
Etaprime B 025-025-100 to 100-100-240.1

Fig. 2: Dimensions of Etaprime B

1)	Pump set with motor foot and motor ≤ 4.0 kW	3)	Pump set with pump foot and motor ≤ 4.0 kW
2)	Pump set with motor foot and motor ≥ 5.5 kW		
6B	Fluid drain	6D	Fluid priming and venting
10A	Barrier fluid outlet (\Rightarrow Page 21)	10E	Barrier fluid inlet (\Rightarrow Page 21)
24A	Quench liquid outlet (\Rightarrow Page 21)	24E	Quench liquid inlet (\Rightarrow Page 21)

Connections

Etaprime B	6B ¹⁵⁾	6D ¹⁵⁾
025-025-100	G 1/8	G 3/8
032-032-120	G 1/8	G 3/8
040-040-110	G 1/8	G 3/8
040-040-140	G 3/8	G 3/8
050-050-130	G 3/8	G 3/8
050-050-160	G 3/8	G 3/8
065-065-150	G 3/8	G 3/8
065-065-180	G 3/8	G 3/8
080-080-170	G 1/2	G 1/2
080-080-190	G 1/2	G 1/2
080-080-200	G 1/2	G 1/2
100-100-240.1	G 1/2	G 1/2

Flange dimensions, shaft unit 17

Etaprime B	Connection	
	Standard	Optional
	DN ¹⁶⁾	DN ¹⁷⁾
025-025-100	Rp 1	NPT 1
032-032-120	Rp 1 1/4	NPT 1 1/4
040-040-110	Rp 1 1/2	NPT 1 1/2

Flange dimensions, shaft units 25, 35

Flanged connection	DN	Bolt circle diameter	z	d	l ₁
Standard:	40	110	4	M16	40
▪ Drilled to EN 1092-1 (material variant C)	50	125	4	M16	40
▪ Drilled to EN 1092-2 (material variant G / GC)	65	145	4	M16	40
	80	160	8	M16	45
	100	180	8	M16	45
Optional:	NPS 1 1/2	98,6	4	UNC 1/2-13	40
▪ Drilled to ASME B16.1 (material variant G / GC)	NPS 2	120,7	4	UNC 5/8-11	40
▪ Drilled to ASME B16.5 (material variant C)	NPS 2 1/2	139,7	4	UNC 5/8-11	40
	NPS 3	152,4	4	UNC 5/8-11	40
	NPS 4	190,5	8	UNC 5/8-11	45

15) Threaded connection to ISO 228/1

16) Standard connection to ISO 7/1

17) Optional connection to ASME B1.20.1

Dimensions [mm]

Etaprime B	n				P _N [kW]	DN	Pump																										
	1450	1750	2900	3500			a	b ₁	b ₂	b ₃	b ₄	b ₅	d ₁	d ₂	d ₃	h ₁	h ₂	h ₃	h ₄	i ₁₈₎	l ₁₈₎	m ₁	m ₂	m ₃	m ₄	n ₁	n ₂	n ₃	n ₄	s ₁	s ₂	w ₁₈₎	x
	[rpm]																																
025-025-100 ¹⁹⁾	X	X	-	-	0,55	25	70	104	95	-	-	33	120	160	9	87	227	38	80	152	441	-	-	100	125	-	-	125	153	-	10	102	60
025-025-100 ¹⁹⁾	-	-	X	X	1,10	25	70	104	95	-	-	33	120	160	9	87	227	38	80	152	473	-	-	100	125	-	-	125	153	-	10	102	60
032-032-120 ¹⁹⁾	X	X	-	-	0,55	32	95	118	95	-	-	33	120	160	9	90	239	46	80	149	463	-	-	100	125	-	-	125	153	-	10	99	60
032-032-120 ¹⁹⁾	-	-	X	-	1,10	32	95	118	95	-	-	33	120	160	9	90	239	46	80	149	495	-	-	100	125	-	-	125	153	-	10	99	60
040-040-110 ¹⁹⁾	X	X	-	-	0,55	40	105	118	110	-	-	33	120	160	9	101	256	55	80	154	478	-	-	100	125	-	-	125	153	-	10	104	60
040-040-110 ¹⁹⁾	-	-	X	X	1,10	40	105	118	110	-	-	33	120	160	9	101	256	55	80	154	510	-	-	100	125	-	-	125	153	-	10	104	60
040-040-140	X	-	-	-	0,55	40	115	128	115	57	16	-	200	162	-	112	284	73	-	-	550	100	70	-	-	220	160	-	-	13	-	166	100
040-040-140	-	X	-	-	1,50	40	115	128	115	57	16	-	200	190	-	112	284	73	-	-	635	100	70	-	-	220	160	-	-	13	-	166	100
040-040-140	-	-	X	-	2,20	40	115	128	115	57	16	-	200	190	-	112	284	73	-	-	635	100	70	-	-	220	160	-	-	13	-	166	100
040-040-140	-	-	X	-	3,00	40	115	128	115	57	16	-	250	213	-	112	284	73	-	-	685	100	70	-	-	220	160	-	-	13	-	180	100
040-040-140	-	-	-	X	4,00	40	115	128	115	57	16	-	250	235	-	112	284	73	-	-	667	100	70	-	-	220	160	-	-	13	-	180	100
040-040-140 ²⁰⁾²¹⁾	-	-	-	X	5,50	40	115	128	115	57	16	55	300	274	12	112	284	73	132	292	731	100	70	140	220	220	160	216	270	13	12	203	100
050-050-130	X	-	-	-	0,55	50	130	138	128	55	16	-	200	162	-	132	317	78	-	-	565	100	70	-	-	250	190	-	-	17	-	166	100
050-050-130	-	X	-	-	1,50	50	130	138	128	55	16	-	200	190	-	132	317	78	-	-	650	100	70	-	-	250	190	-	-	17	-	166	100
050-050-130	-	-	X	-	2,20	50	130	138	128	55	16	-	200	190	-	132	317	78	-	-	650	100	70	-	-	250	190	-	-	17	-	166	100
050-050-130	-	-	X	-	3,00	50	130	138	128	55	16	-	250	213	-	132	317	78	-	-	700	100	70	-	-	250	190	-	-	17	-	180	100
050-050-130	-	-	-	X	4,00	50	130	138	128	55	16	-	250	235	-	132	317	78	-	-	682	100	70	-	-	250	190	-	-	17	-	180	100
050-050-130	-	-	-	X	5,50	50	130	138	128	55	16	55	300	274	12	132	317	78	132	292	746	100	70	140	220	250	190	216	270	17	12	203	100
050-050-160	X	-	-	-	0,55	50	130	145	126	55	16	-	200	162	-	132	327	75	-	-	565	100	70	-	-	250	190	-	-	17	-	166	100
050-050-160	-	X	-	-	1,50	50	130	145	126	55	16	-	200	190	-	132	327	75	-	-	650	100	70	-	-	250	190	-	-	17	-	166	100
050-050-160	-	-	X	-	4,00	50	130	145	126	55	16	-	250	235	-	132	327	75	-	-	682	100	70	-	-	250	190	-	-	17	-	180	100
050-050-160	-	-	X	X	5,50	50	130	145	126	55	16	55	300	274	12	132	327	75	132	292	746	100	70	140	220	250	190	216	270	17	12	203	100
050-050-160	-	-	-	X	7,50	50	130	145	126	55	16	55	300	274	12	132	327	75	132	292	790	100	70	140	220	250	190	216	270	17	12	203	100
065-065-150	X	-	-	-	0,55	65	140	155	149	55	16	-	200	162	-	160	370	85	-	-	575	125	95	-	-	270	212	-	-	20	-	166	100
065-065-150	-	X	-	-	1,50	65	140	155	149	55	16	-	200	190	-	160	370	85	-	-	660	125	95	-	-	270	212	-	-	20	-	166	100
065-065-150	-	-	X	-	4,00	65	140	155	149	55	16	-	250	235	-	160	370	85	-	-	692	125	95	-	-	270	212	-	-	20	-	180	100
065-065-150 ²⁰⁾²¹⁾	-	-	X	X	5,50	65	140	155	149	55	16	55	300	274	12	160	370	85	132	292	756	125	95	140	220	270	212	216	270	20	12	203	100
065-065-150 ²⁰⁾²¹⁾	-	-	-	X	7,50	65	140	155	149	55	16	55	300	274	12	160	370	85	132	292	800	125	95	140	220	270	212	216	270	20	12	203	100
065-065-180	X	X	-	-	2,20	65	140	158	138	55	16	-	250	213	-	160	376	89	-	-	740	125	95	-	-	270	212	-	-	18	-	210	140
065-065-180 ²⁰⁾²¹⁾	-	-	X	-	5,50	65	140	158	138	55	16	55	300	274	12	160	376	89	132	322	786	125	95	140	220	270	212	216	270	18	12	233	140

- 18) Dimensions for variants with a single mechanical seal
 19) Shim the motor feet by 30 mm.
 20) If h₁ > h₄: shim the motor meet.
 21) If h₁ < h₄: shim the pump feet.

Etaprime B	n				P _N [kW]	DN	Pump																										
	1450	1750	2900	3500			a	b ₁	b ₂	b ₃	b ₄	b ₅	d ₁	d ₂	d ₃	h ₁	h ₂	h ₃	h ₄	i ₁₈₎	l ₁₈₎ (approx.)	m ₁	m ₂	m ₃	m ₄	n ₁	n ₂	n ₃	n ₄	s ₁	s ₂	w ₁₈₎	x
	[rpm]																																
065-065-180 ²⁰⁾²¹⁾	-	-	X	-	7,50	65	140	158	138	55	16	55	300	274	12	160	376	89	132	322	830	125	95	140	220	270	212	216	270	18	12	233	140
065-065-180	-	-	-	X	11,00	65	140	158	138	55	16	70	350	325	15	160	376	89	160	374	952	125	95	210	310	270	212	254	323	18	15	266	140
080-080-170	X	X	-	-	2,20	80	156	173	168	65	18	-	250	213	-	160	380	104	-	-	756	140	106	-	-	310	240	-	-	18	-	210	140
080-080-170 ²⁰⁾²¹⁾	-	-	X	-	7,50	80	156	173	168	65	18	55	300	274	12	160	380	104	132	322	846	140	106	140	220	310	240	216	270	18	12	233	140
080-080-170	-	-	-	X	15,00	80	156	173	168	65	18	70	350	325	15	160	380	104	160	374	968	140	106	210	310	310	240	254	323	18	15	266	140
080-080-190	X	X	-	-	2,20	80	170	188	181	65	20	-	250	213	-	180	420	107	-	-	770	160	120	-	-	345	280	-	-	22	-	210	140
080-080-190 ²⁰⁾²¹⁾	-	-	-	X	11,00	80	170	188	181	65	20	70	350	325	15	180	420	107	160	374	982	160	120	210	310	345	280	254	323	22	15	266	140
080-080-190 ²⁰⁾²¹⁾	-	-	-	X	18,50	80	170	188	181	65	20	70	350	325	15	180	420	107	160	374	1018	160	120	254	314	345	280	254	323	22	15	266	140
080-080-200	X	X	-	-	2,20	80	154	172	152	65	20	-	250	213	-	160	378	107	-	-	754	140	100	-	-	285	220	-	-	22	-	210	140
080-080-200	-	-	X	-	11,00	80	154	172	152	65	20	70	350	325	15	160	378	107	160	374	966	140	100	210	310	285	220	254	323	22	15	266	140
080-080-200	-	-	-	X	15,00	80	154	172	152	65	20	70	350	325	15	160	378	107	160	374	966	140	100	210	310	285	220	254	323	22	15	266	140
100-100-240.1	X	-	-	-	2,20	100	182	203	178	68	20	-	250	213	-	200	457	127	-	-	771	140	100	-	-	330	260	-	-	18	-	199	140
100-100-240.1	X	X	-	-	3,00	100	182	203	178	68	20	-	250	213	-	200	457	127	-	-	771	140	100	-	-	330	260	-	-	18	-	199	140
100-100-240.1	-	X	-	-	4,00	100	182	203	178	68	20	-	250	235	-	200	457	127	-	-	753	140	100	-	-	330	260	-	-	18	-	199	140
100-100-240.1 ²⁰⁾²¹⁾	-	-	X	-	18,50	100	182	203	178	68	20	70	350	325	15	200	457	127	160	363	1019	140	100	254	314	330	260	254	323	18	15	255	140
100-100-240.1	-	-	-	X	30,00	100	182	203	178	68	20	85	400	422	19	200	457	127	200	388	1106	140	100	305	388	330	260	318	404	18	19	255	140

Flange designs

Symbols key

Symbol	Description
X	Standard
o	Option

Threaded connections, shaft unit 17

Size	Shaft unit	Material variant			
		G/GC/C			
		Connection pipe thread to			
		ISO 7-1 PN10		ASME B1.20.1 PN10	
025-025-100	17	Rp 1	X	NPT 1	o
032-032-120	17	Rp 1 1/4	X	NPT 1 1/4	o
040-040-110	17	Rp 1 1/2	X	NPT 1 1/2	o

Flanged connections²²⁾ shaft units 25, 35

Size	Shaft unit	Nominal size to		Material variant			
				G/GC		C	
				Flange dimensions to			
		EN 1092-2		EN 1092-1			
		Drilled to				EN 1092-2 PN16	ASME B16.1 CL125
040-040-110	25	DN 40	NPS 1 1/2	X	o	X	o
050-050-130		DN 50	NPS 2	X	o	X	o
050-050-160		DN 50	NPS 2	X	o	X	o
065-065-150		DN 65	NPS 2 1/2	X	o	X	o
065-065-180	35	DN 65	NPS 2 1/2	X	o	X	o
080-080-170		DN 80	NPS 3	X	o	X	o
080-080-190		DN 80	NPS 3	X	o	-	-
080-080-200		DN 80	NPS 3	X	o	X	o
100-100-240.1		DN 100	NPS 4	X	o	-	-

22) Type RF (Raised Face)

Interchangeability of Etaprime B and Etaprime L pump components

Components featuring the same number in a column are interchangeable.

Symbols key

Symbol	Description
*	Component interchangeable with Etaprime L
○	Components differ
✕	Component not fitted

Interchangeability of Etaprime B and Etaprime L pump components and interchangeability of components among each other

Size	Shaft unit	Description					
		Volute casing	Casing cover	Shaft	Impeller	Mechanical seal	Shaft sleeve
		Part No.					
		102	161	210	230	433	523
025-025-100	17	○*	✕	1	○*	1*	✕
032-032-120	17	○*	✕	1	○*	1*	✕
040-040-110	17	○*	✕	1	○*	1*	✕
040-040-140	25	○*	○*	2	○*	2*	1*
050-050-130	25	○*	○*	2	○*	2*	1*
050-050-160	25	○*	1*	2	○*	2*	1*
065-065-150	25	○*	1*	2	○*	2*	1*
065-065-180	35	○*	○*	3	○*	3*	2*
080-080-170	35	○*	○*	3	○*	3*	2*
080-080-190	35	○*	○*	3	○*	3*	2*
080-080-200	35	○*	○*	3	○*	3*	2*
100-100-240.1	35	○*	○*	3	○*	3*	2*

Scope of supply

Depending on the model, the following items are included in the scope of supply:

- Pump
- Surface-cooled IEC three-phase current squirrel-cage motor
- Cover plates at drive lantern to EN 294

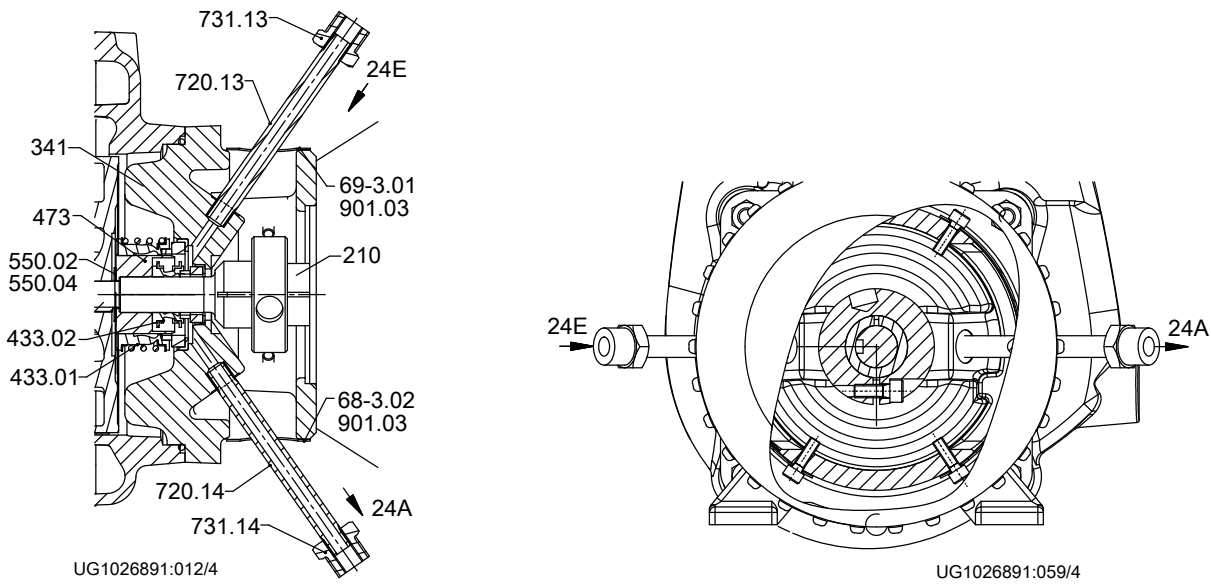

Fig. 4: Variant with double mechanical seal in tandem arrangement

List of components

Part No.	Description	Part No.	Description
210	Shaft	550.02/.04	Disc
341	Drive lantern	68-3.01/.02	Cover plate
433.01	Mechanical seal (inboard)	720.13/.14	Fitting
433.02	Mechanical seal (outboard)	731.13/.14	Reducing nipple
473	Primary ring carrier	901.03	Hexagon head bolt

Connections

Part No.	Description	Part No.	Description
24A	Quench liquid outlet	24E	Quench liquid inlet

Etaprime G and C with flanged connection (SU 25 and SU 35)

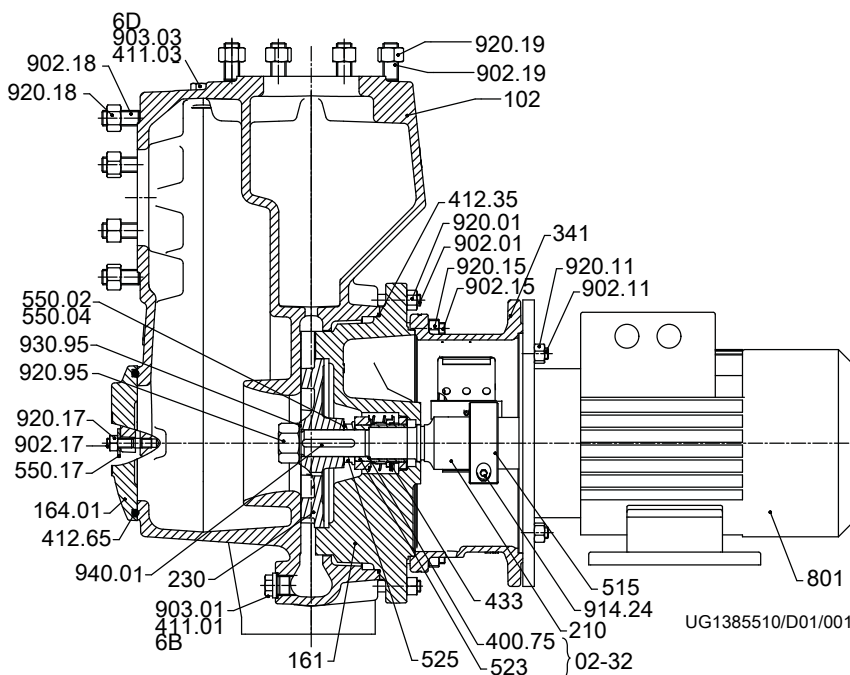

Fig. 5: Variant with a single mechanical seal

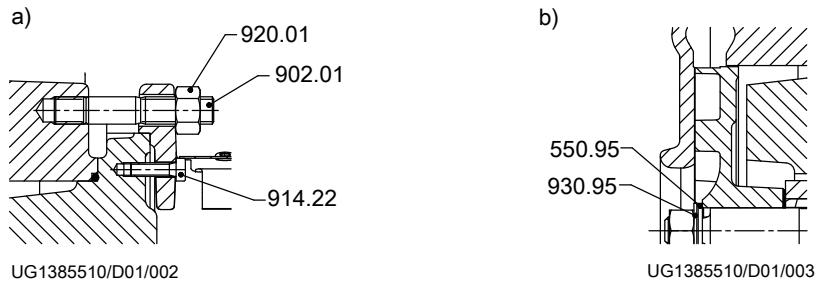

Fig. 6: a) Clamped casing cover, b) impeller fastening elements for shaft unit 25
[Supplied in packaging units only

List of components

Part No.	Description	Part No.	Description
102	Volute casing	525 ²³⁾	Spacer sleeve
161	Casing cover	550.02/.04/.17	Disc
164.01	Inspection cover	550.95 ²⁴⁾	Disc
210	Shaft	68-3.01/.02	Cover plate
230	Impeller	801	Flanged motor
341	Drive lantern	902.01/.11/.15/.17/.18/.19	Stud
400.75	Gasket	903.01/.03	Screw plug
411.01/.03	Joint ring	914.22/.24	Hexagon socket head cap screw
412.35/.65	O-ring	920.01/.05/.11/.15/.17/.18/.19/.95	Nut
433	Mechanical seal	930.95	Safety device
515	Locking ring	940.01	Key
523	Shaft sleeve		

Connections

Part No.	Description	Part No.	Description
6B	Fluid drain	6D	Fluid priming and venting

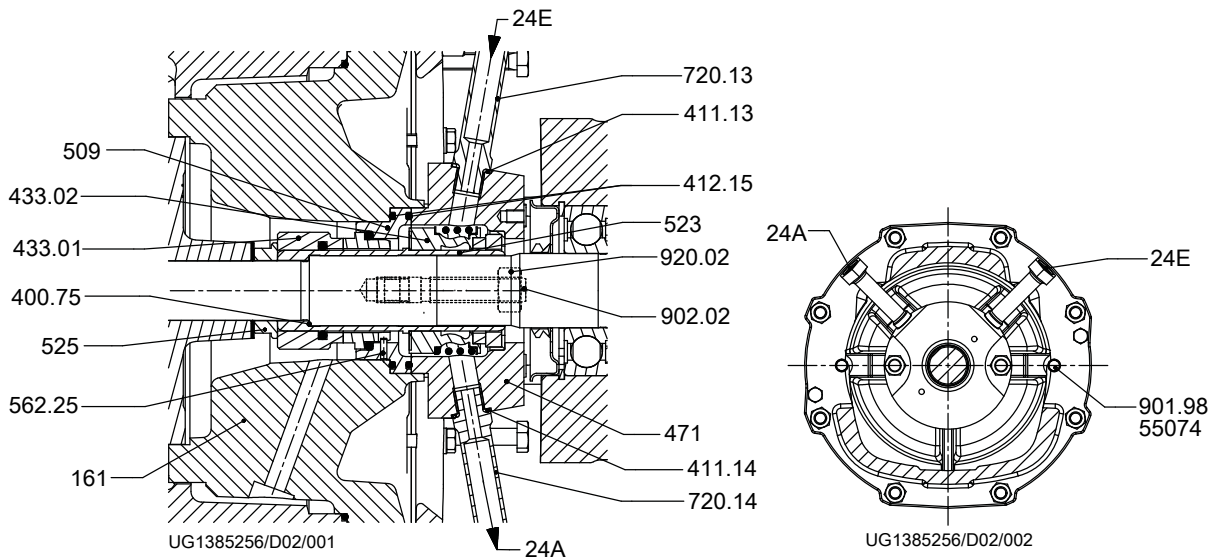

Fig. 7: Variant with double mechanical seal in tandem arrangement

List of components

Part No.	Description	Part No.	Description
161	Casing cover	509	Intermediate ring
400.75	Gasket	523	Shaft sleeve
411.13/.14	Joint ring	525 ²⁵⁾	Spacer sleeve

23) For shaft unit 35 only; shaft unit see data sheet.

24) For shaft unit 25 only; shaft unit see data sheet.

25) For shaft unit 35 only; shaft unit see data sheet.

Part No.	Description	Part No.	Description
412.15	O-ring	562.25	Parallel pin
433.01	Mechanical seal (inboard)	720.13/.14	Fitting
433.02	Mechanical seal (outboard)	902.02	Stud
471	Seal cover	920.02	Nut

Connections

Part No.	Description	Part No.	Description
24A	Quench liquid outlet	24E	Quench liquid inlet

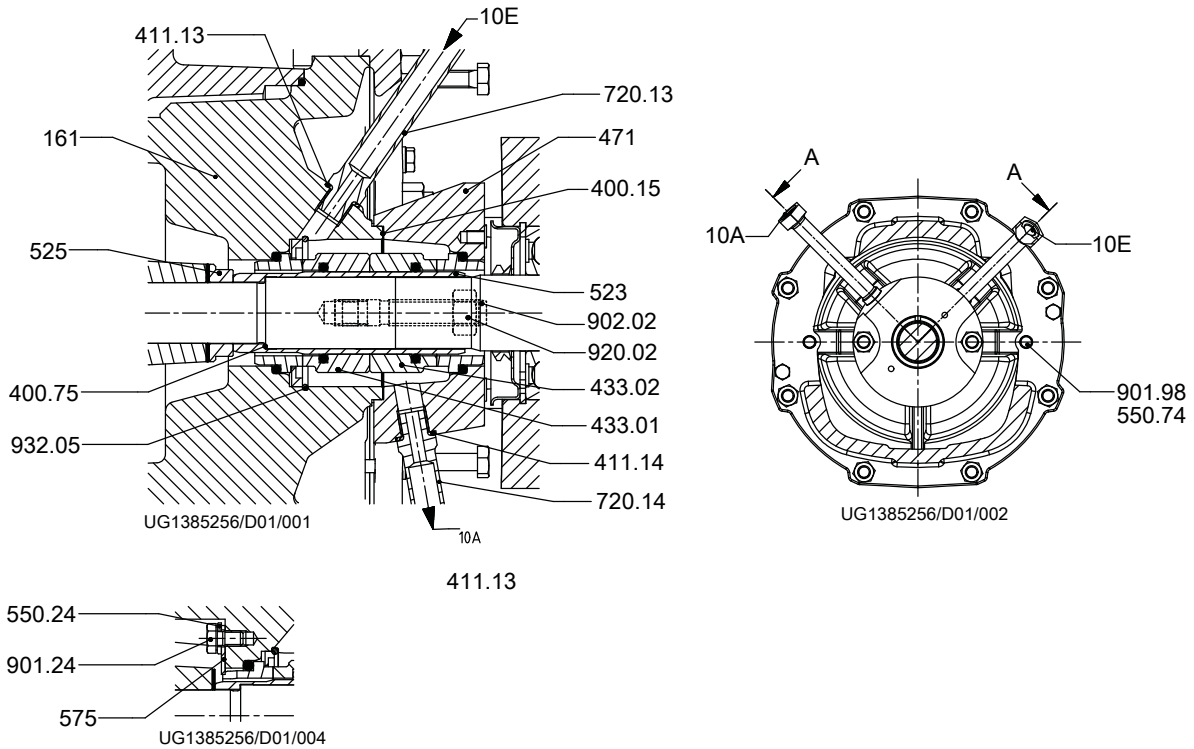

Fig. 8: Variant with double mechanical seal in back-to-back arrangement

List of components

Part No.	Description	Part No.	Description
161	Casing cover	550.24	Disc
400.15 ²⁶⁾ /.75	Gasket	575	Lug
411.13/.14	Joint ring	720.13/.14	Fitting
433.01	Mechanical seal (inboard)	901.24	Hexagon head bolt
433.02	Mechanical seal (outboard)	902.02	Stud
471	Seal cover	920.02	Nut
523	Shaft sleeve	932.05	Circlip
525 ²⁷⁾	Spacer sleeve		

Connections

Part No.	Description	Part No.	Description
10A	Barrier fluid outlet	10E	Barrier fluid inlet

26) Only for shaft unit 25: joint ring 411.15
27) For shaft unit 35 only; shaft unit see data sheet.



KSB Aktiengesellschaft
Johann-Klein-Straße 9 • 67227 Frankenthal (Germany)
Tel. +49 6233 86-0
www.ksb.com