

## AJ30G411R55MA

### SOTR

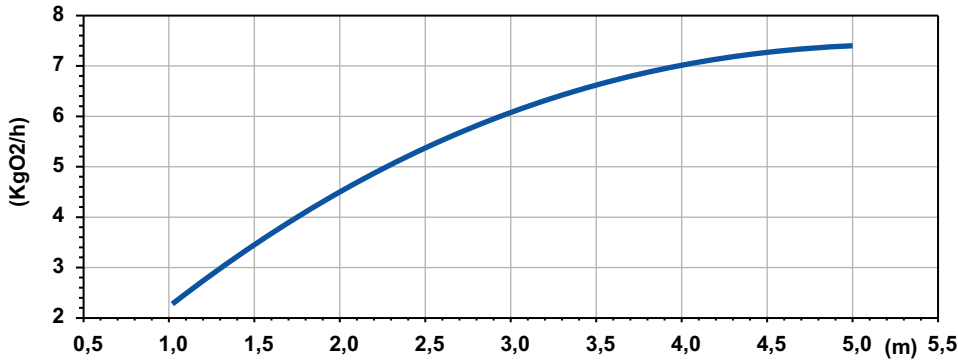

Potenza Assorbita - Absorbed Power P1  
 Puissance Absorbée - Leistungsaufnahme P1  
 Potencia Absorbida - Поглощенная мощность P1

Aria Aspirata - Suction Air  
 L'air D'aspiration - Saugluft  
 Succión De Aire - Аспирированный воздух  
 Nm<sup>3</sup> a 0 °C, RH 0 %, p = 101,3 kPa

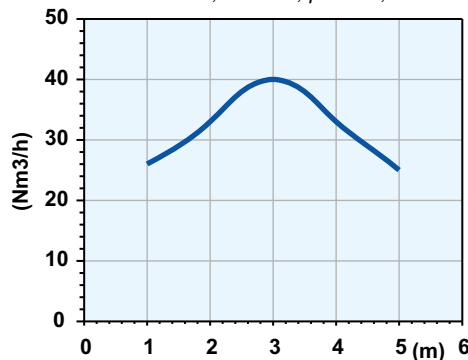
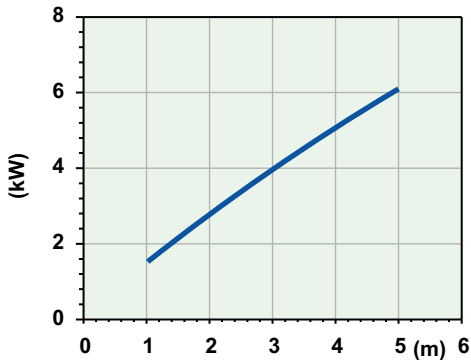

Battente idraulico - Hydraulic head - Charge hydraulique - Hydraulischen Belastung  
 Cabezal hidráulico - Гидронапор

Code	5009652
Type	<b>AJ30G411R55MA</b>
Suction (mm)	DN80
Free passage (mm)	30x32
Immersion depth (m)	1-5
Motor type	M411T-7,1-400/50YY-IE3
Power supply	3ph 400/690V-50Hz
MOTOR Rotation speed R.P.M.	1436
Rated power P2 (kW)	7,1
Rated current I (A)	13,5
Starting current Is (A)	79,6
Weight (Kg)	155
Cable	H07RN/F 12G2.5
SOTR OBTAINED FOLLOWING STANDARD UNI EN 12255-15:2004	

### Dimensioni - Dimensions - Dimensions - Abmessungen - Dimensiones - Габариты (mm)

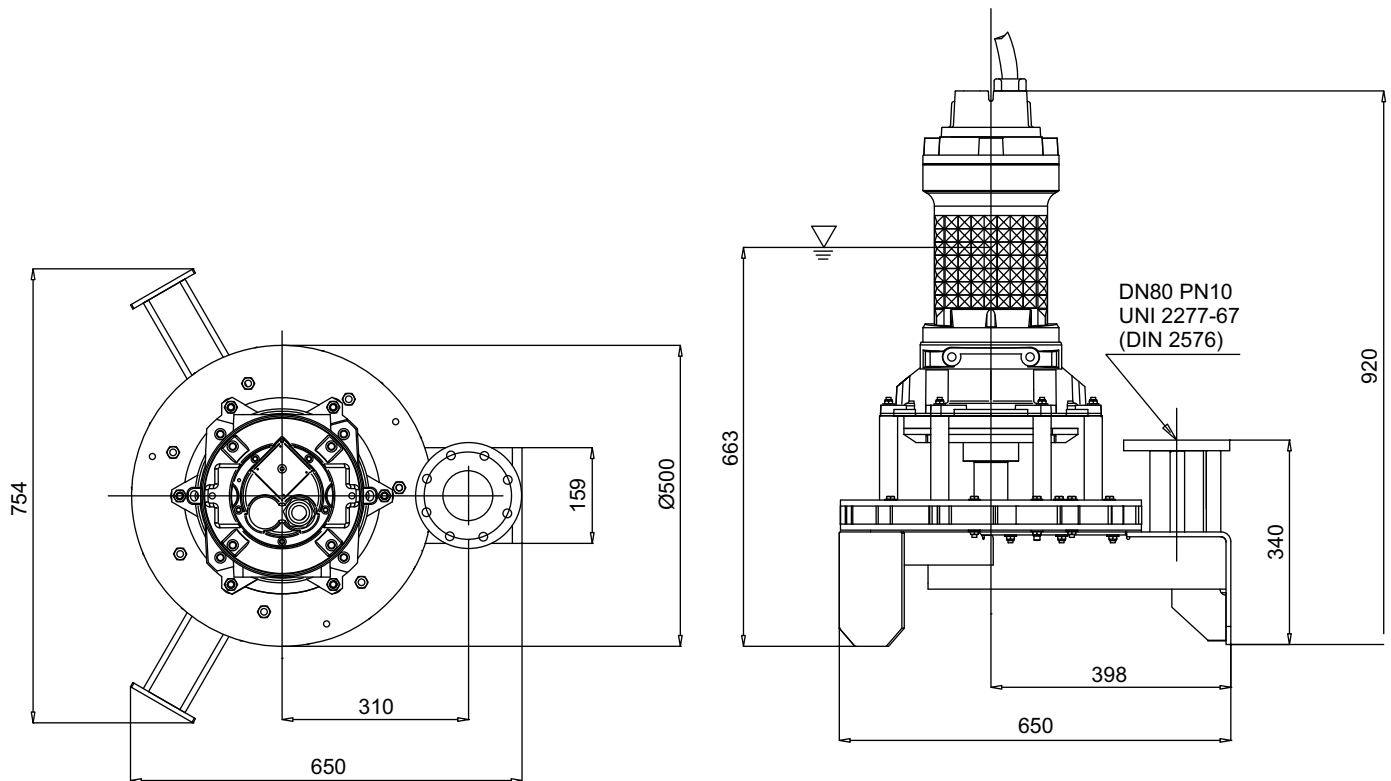

LIVELLO MINIMO DI SOMMERGIBILITÀ - MINIMUM SUBMERSIBLE LEVEL - NIVEAU MINIMUM D'IMMERSION  
 MINDESTWASSERSTAND - NIVEL SUMERGIBLE MÍNIMO - МИНИМАЛЬНАЯ ГЛУБИНА ПОГРУЖЕНИЯ