

UTS^{HE} / UTS-B^{HE}

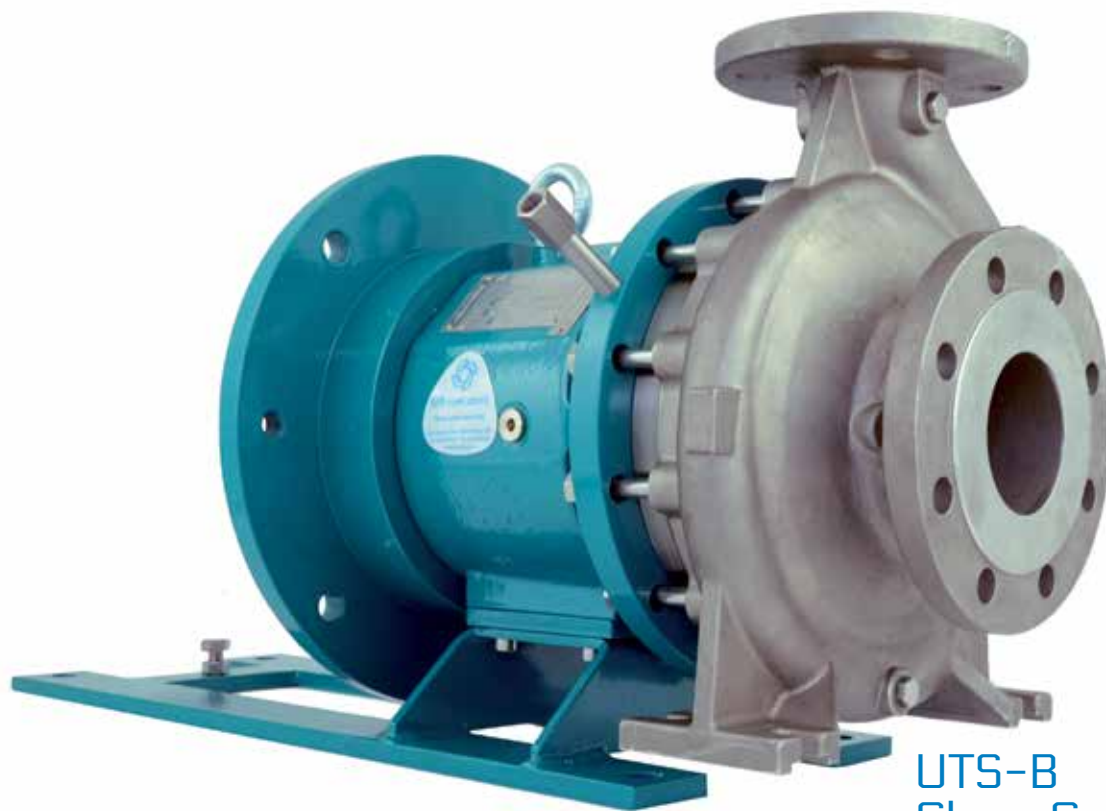

UTS-B
Close Coupled Execution



Comply to :
2006/42/CE

Design to :
ISO 2858 / EN 22858
(ex DIN 24256)

ISO 5199 - UNI 15783



ATEX 100
Directive 94/9/EC

Flanged
UNI 1092-1 (ISO 7005-1)
PN16 RF type B

Metallic Magnetic drive Horizontal - Single Stage - Process Centrifugal pumps

Materials : AISI 316 (1.4408)

Close-coupled and End-suction executions

HE: High Efficiency

UTS SERIES

Mag drive concept

The synchronous drive configuration is based on an outer magnet ring assembly built to magnetically couple with an inner magnet ring assembly.

These two magnet rings are locked together by the flux of attracting magnet poles flowing through the containment isolation shell.



UTS

End suction pumps use the back pull-out principle and a strong bearing housing with flexible coupling.



UTS-B

Close coupled pumps are furnished with standard motors.

Versatility

Suitable for handling aggressive, toxic and hazardous liquids (low viscosity, clean or slightly contaminated) in the chemical, petrochemical and pharmaceutical industries, where the need of high safety standards is the first requirement.

Reliability

The UTS are made by stainless steel AISI 316 : on bare shaft execution, the pump is also equipped as a standard with reliable oil lubricated bearing bracket, especially developed to be suitable even under heavy duty service.

Design

UTS range shares the same hydraulic design with the UCS series (mechanical seal pumps) which have been developed focusing on Industry's requests.

Application Fields

Refinery Industry



Chemical Processing



Fine Chemical Processing



Thermoregulation



Fibre Processing



Pharmaceutical Industry



UTS SERIES

Inner and Outer magnets are equipped with NdFeB (neodymium iron boron) and SmCo (samarium cobalt) permanent magnets.

Patented cage magnet attachment guarantees stability during the operation of the pump.

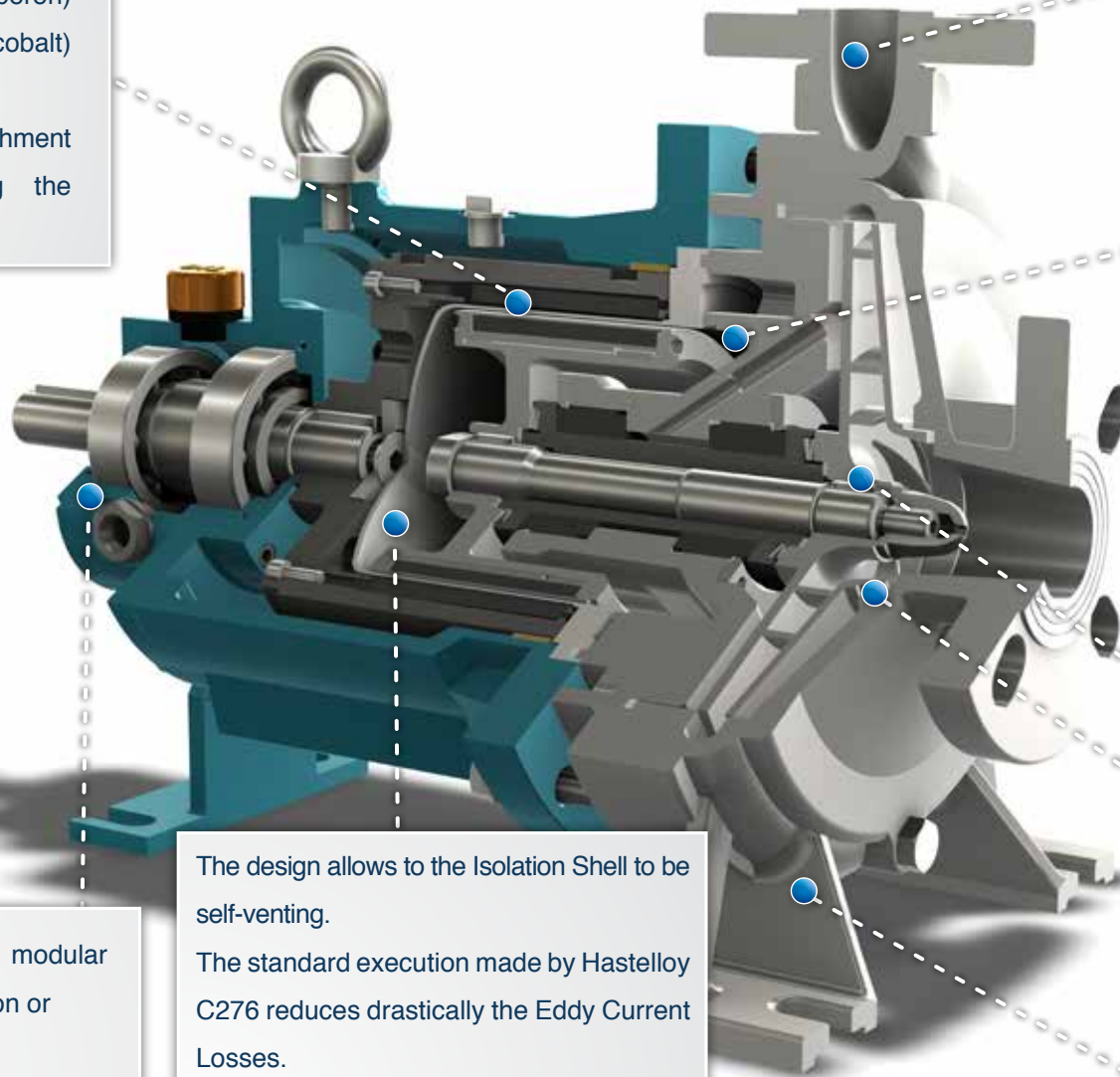

Top centerline discharge for air handling, self-venting .

Internal Flushing paths developed to remove the maximum amount of heat generated by the bushing rotation and Eddie Current on the Isolation Shell.

The problem of reverse rotation during start-up has been eliminated thanks to the key driven system.

Renewable wear ring as standard.

Integral cast feet provides maximum resistance to pipe loads and prevent pipe load misalignment, maximizing seal and bearing life.

The design allows to the Isolation Shell to be self-venting.

The standard execution made by Hastelloy C276 reduces drastically the Eddy Current Losses.

The pump design grants a modular configuration of either end-suction or close-coupled design.



CASING

- Bonus casing thickness : minimum 3 mm corrosion allowance maximizes casing life against corrosion and erosion
- Standard casing drain for a complete and fast draining of the casing
- Heating \ Cooling jacket option available



IMPELLER

- Investment casted AISI 316 (1.4408) closed impeller design provides maximum efficiency and reliability
- Standard back vanes reduce axial thrust and seal chamber pressures to guarantee an extraordinary bearing and seal life



ISOLATION SHELL

- The design allow to the Isolation Shell to be self-venting and fully drainable.
- The rib on the bottom is a perfect vortex breaker which increase the life time.
- Isolation shell temperature probe connection provided as a standard.

BUSHING SUPPORT

- Internal flushing paths developed to remove the maximum amount of heat generated by the bushing rotation and Eddie Current on the Isolation Shell.



STATIC AND ROTATING BUSHINGS

- The rotating metallic shaft is installed inside a SiC Bushing supported by double static bushings : this design grants a long service life time sharing equally the mechanical efforts
- Optional : Static Graphite Bushings

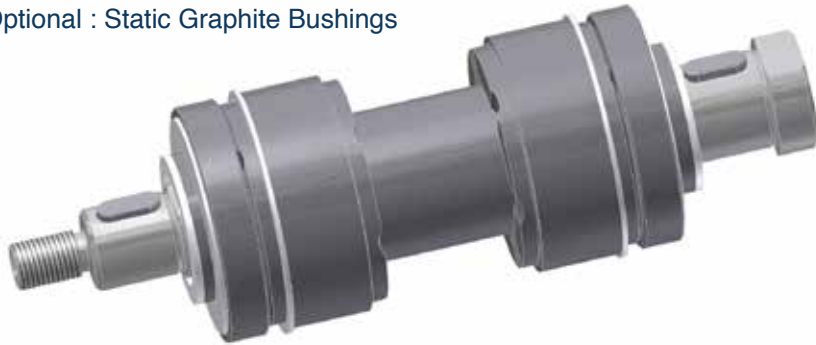

PAINTING COATING QUALITY

The metal surfaces are protected by a high performance three coating layers (240 micron)

- Epoxy zinc paint
- Epoxy amide modified vinyl
- Epoxy enamel paint or aliphatic acrylic polyurethane

Available upon request :

EN ISO 12944-5 C5M and C5I protecting paint system grades.



HIGH TEMPERATURE EXECUTION

Inner and Outer magnets are equipped with :

- NdFeB (neodymium iron boron) permanent magnets for working temperatures up to 180°C
- SmCo (samarium cobalt) permanent magnets for working temperatures from 180°C to 300°C

Options for high temperature executions (over 180°C):

- Antimony Graphite Bushings
- Continuous Service Bearing Support execution ready for Labtecta (non-contacting Labyrinth seal)

LOW TEMPERATURE EXECUTION

Inner and Outer magnets are equipped with SmCo (samarium cobalt) permanent magnets for working temperatures till -110°C.

Options for low temperature executions:

- Lantern and external magnet made by cast steel UNI C40
- Lantern in AISI 316 or AISI 304 and external magnet made by cast steel UNI C40

SECTIONAL DRAWING 1° FRAME

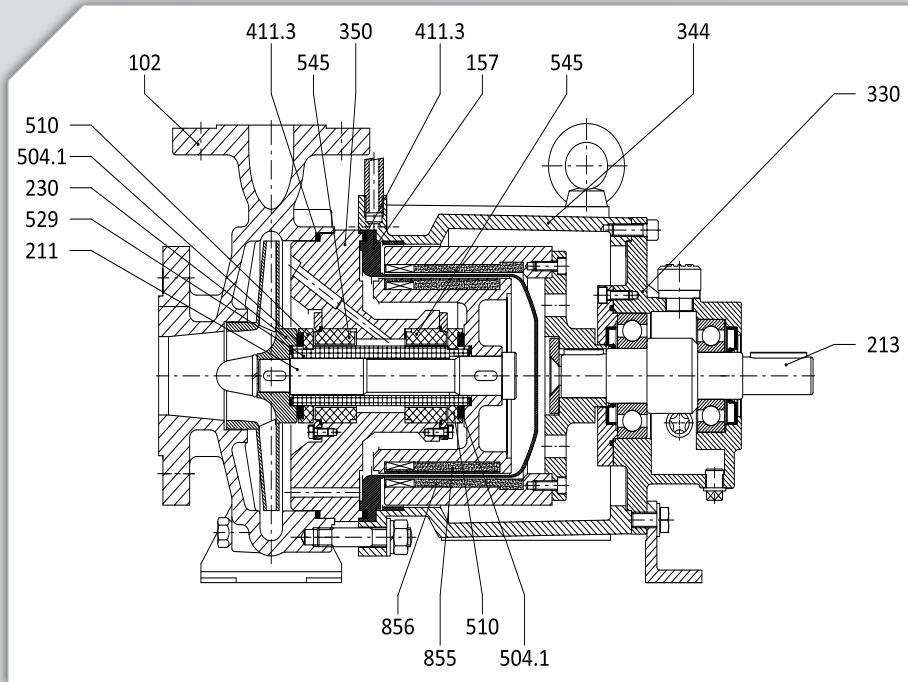

UTS-B

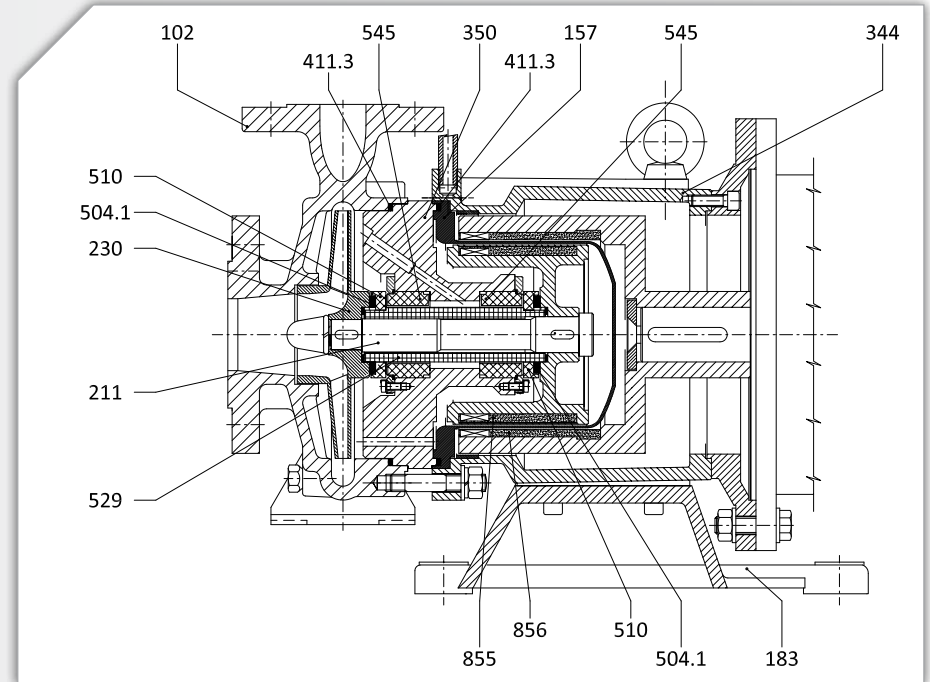

Part list

Performances 2900 rpm	Q max = 80 m3/h -> H max = 65 mcl
Electric Motors	<ul style="list-style-type: none"> • UTS-B : 0.75 kW (motor size 80) -> 18.5 kW (motor size 160) • UTS : 0.75 kW (motor size 80) -> 18.5 kW (motor size 160)
Temperature range	<ul style="list-style-type: none"> • UTS-B : -40 °C* -> +180 °C • UTS : -40 °C* -> +300 °C <p>* -100 °C special execution</p>
Allowable Pressure Range	<ul style="list-style-type: none"> • UTS series 125/160 : 16 bar (20 °C) • UTS series 200 : 16 bar (20 °C)
Flange Connections	<ul style="list-style-type: none"> • UNI 1092-1 / ISO 7005-1 PN 16, type B • upon request, drilling slotted to match ANSI 150
Viscosity	min : 1cSt - max : 100 cSt
Allowable Solids	<ul style="list-style-type: none"> • Max concentration 2 % by weight • Max particle size 0,15 mm

DIN	Component	Material
102	Casing	AISI 316 (1.4408-CF8M)
157	Isolation Shell	Hastelloy C + AISI 316L
211	Pump Shaft	AISI 316 (1.4401)
213	Shaft	Steel C45
230	Impeller	AISI 316 (1.4408-CF8M)
330	Bearing bracket	GS400
344	Lantern	GS400 (C40*- AISI316*) * special execution
350	Bushings Support	AISI 316L (1.4409-CF3M)
411.x	O-Ring	PTFE \ Grafoil
504	Spacer Ring	PTFE \ Armored Grafoil
510	Thrust Bearing	SiC \ RunSafeSiC
529	Bearing Sleeve	SiC \ RunSafeSiC
545	Bearing Bush	SiC \ Graphite \ PEEK \ RunSafeSiC
855	Inner Magnet	AISI 316L (1.4404)
856	Outer Magnet	GS400 \ HT execution

UTS

Technical Specifications

SECTIONAL DRAWING II° FRAME

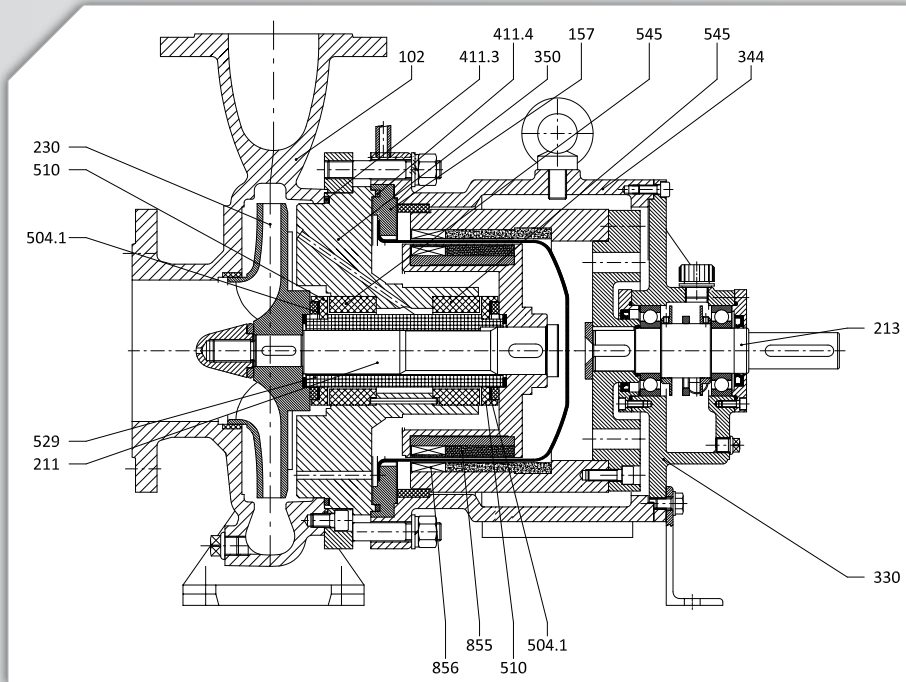

UTS-B

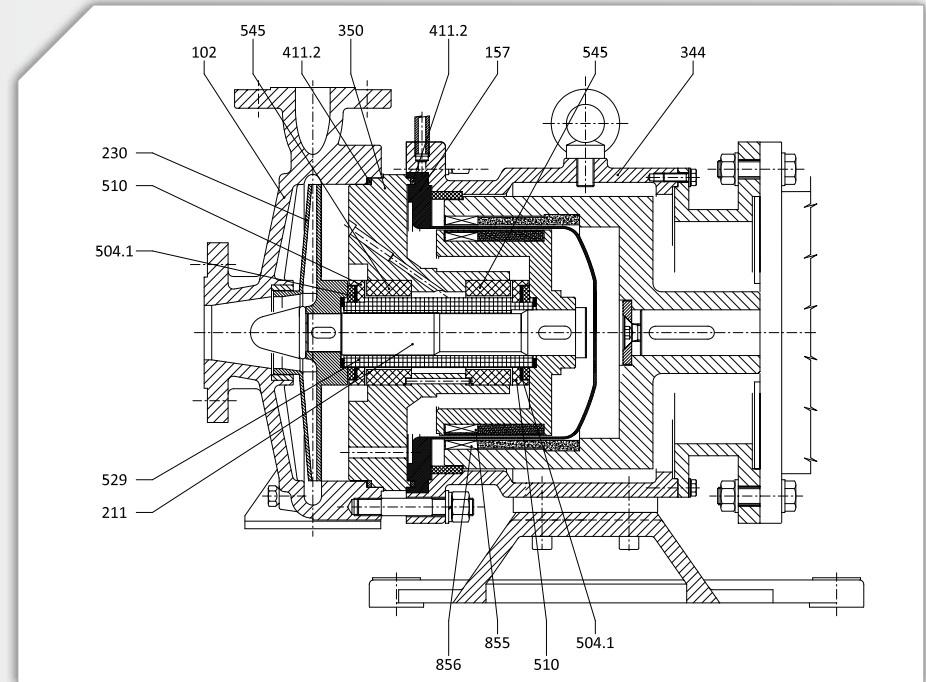

Part list

UTS

Technical Specifications

Performances 2900 rpm	Q max = 230 m3/h -> H max = 95 mcl
Electric Motors	<ul style="list-style-type: none"> • UTS-B : 1,1 kW (motor size 80) -> 18.5 kW (motor size 160) • UTS : 1,1 kW (motor size 80) -> 55 kW (motor size 250)
Temperature range	<ul style="list-style-type: none"> • UTS-B : -40 °C* -> +180 °C • UTS : -40 °C* -> +300 °C * -100 °C special execution
Allowable Pressure Range	<ul style="list-style-type: none"> • UTS series 160 : 16 bar (20 °C) • UTS series 200 /250 : 16 bar (20 °C)
Flange Connections	<ul style="list-style-type: none"> • UNI 1092-1 / ISO 7005-1 PN 16, type B • upon request, drilling slotted to match ANSI 150
Viscosity	min : 1cSt - max : 100 cSt
Allowable Solids	<ul style="list-style-type: none"> • Max concentration 2 % by weight • Max particle size 0,15 mm

DIN	Component	Material
102	Casing	AISI 316 (1.4408-CF8M)
157	Isolation Shell	Hastelloy C + AISI 316L
211	Pump Shaft	AISI 316 (1.4401)
213	Shaft	Steel C45
230	Impeller	AISI 316 (1.4408-CF8M)
330	Bearing bracket	GS400
344	Lantern	GS400 (C40*- AISI316*) * special execution
350	Bushings Support	AISI 316L (1.4409-CF3M)
411.x	O-Ring	PTFE \ Grafoil
504	Spacer Ring	PTFE \ Armored Grafoil
510	Thrust Bearing	SiC
529	Bearing Sleeve	SiC
545	Bearing Bush	SiC \ Graphite \ PEEK
855	Inner Magnet	AISI 316L (1.4404)
856	Outer Magnet	GS400 \ HT execution

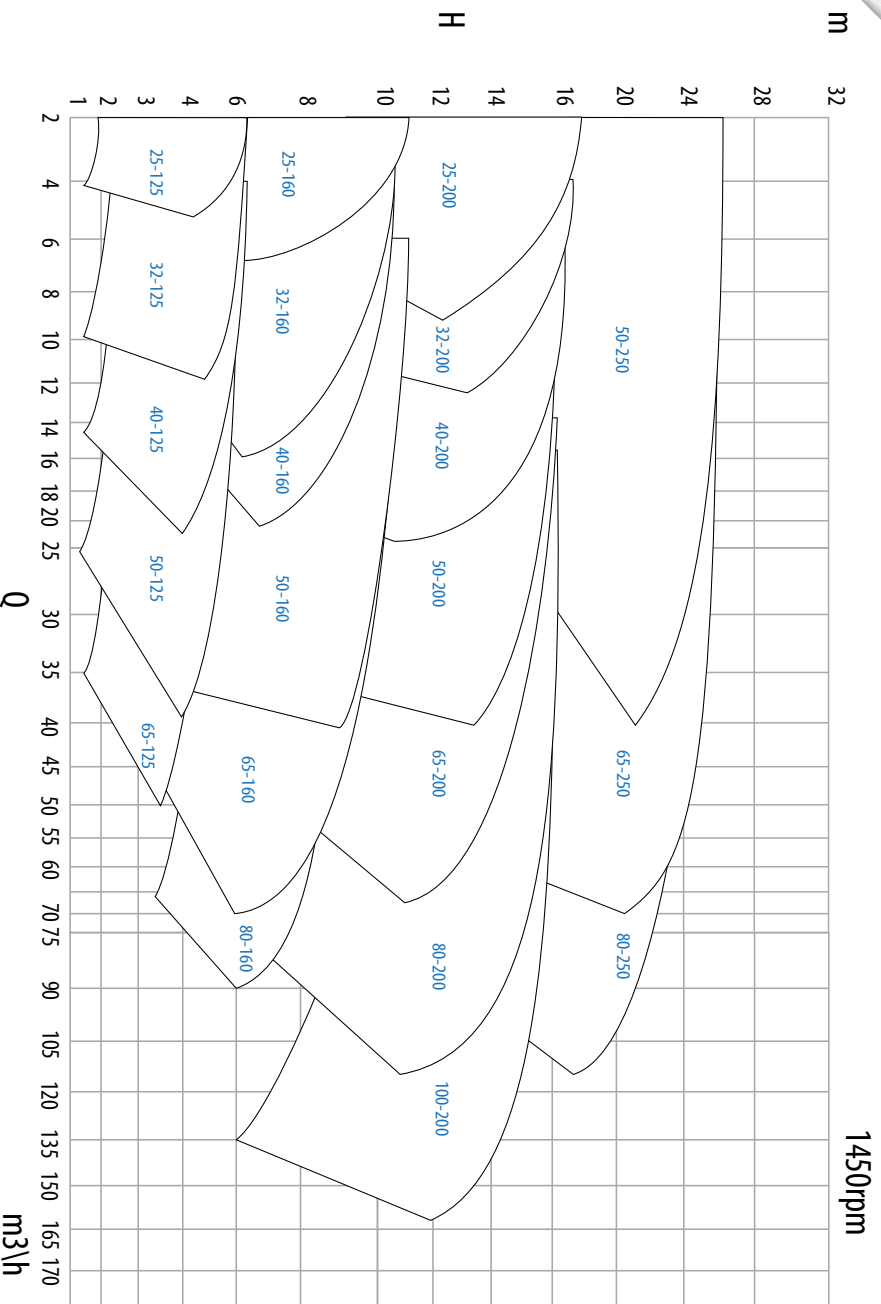
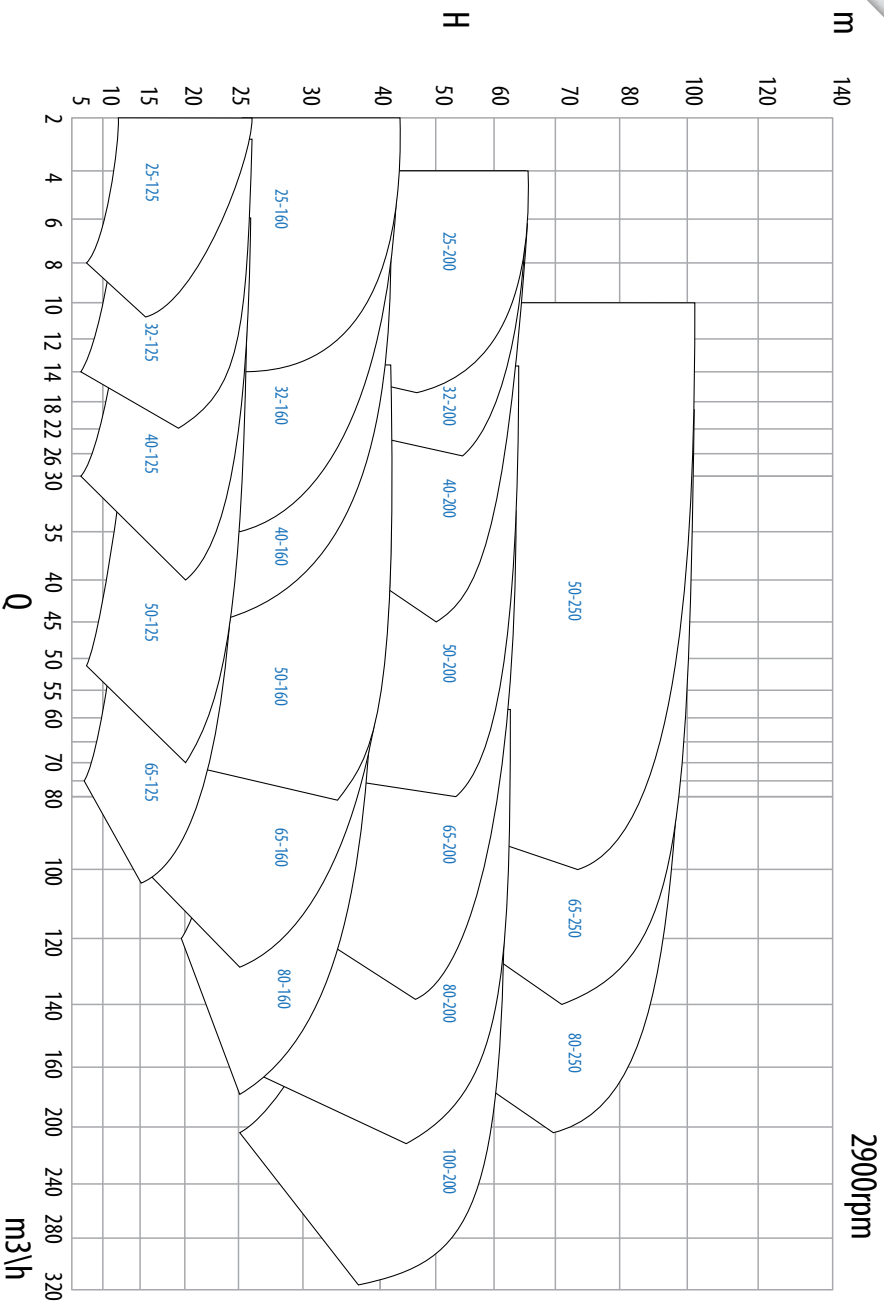

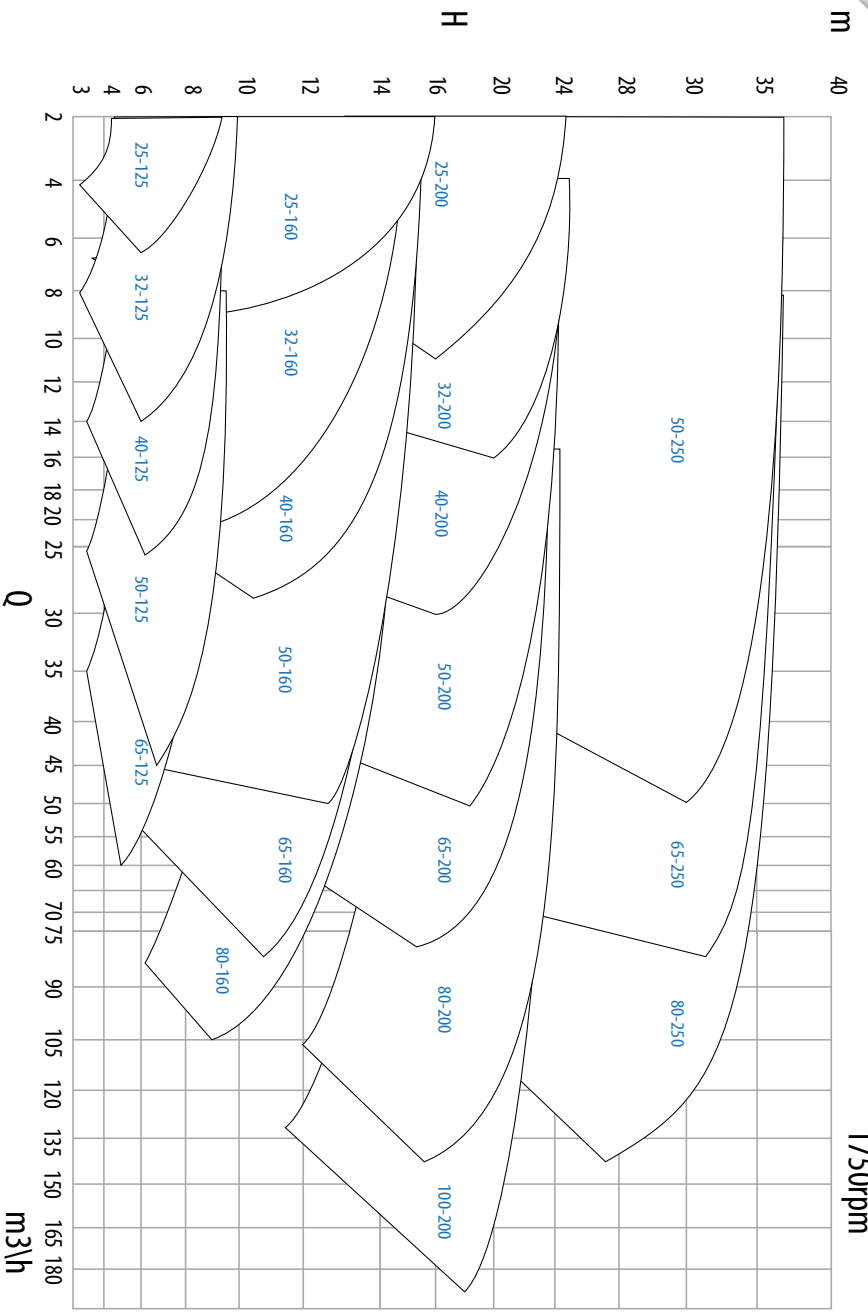
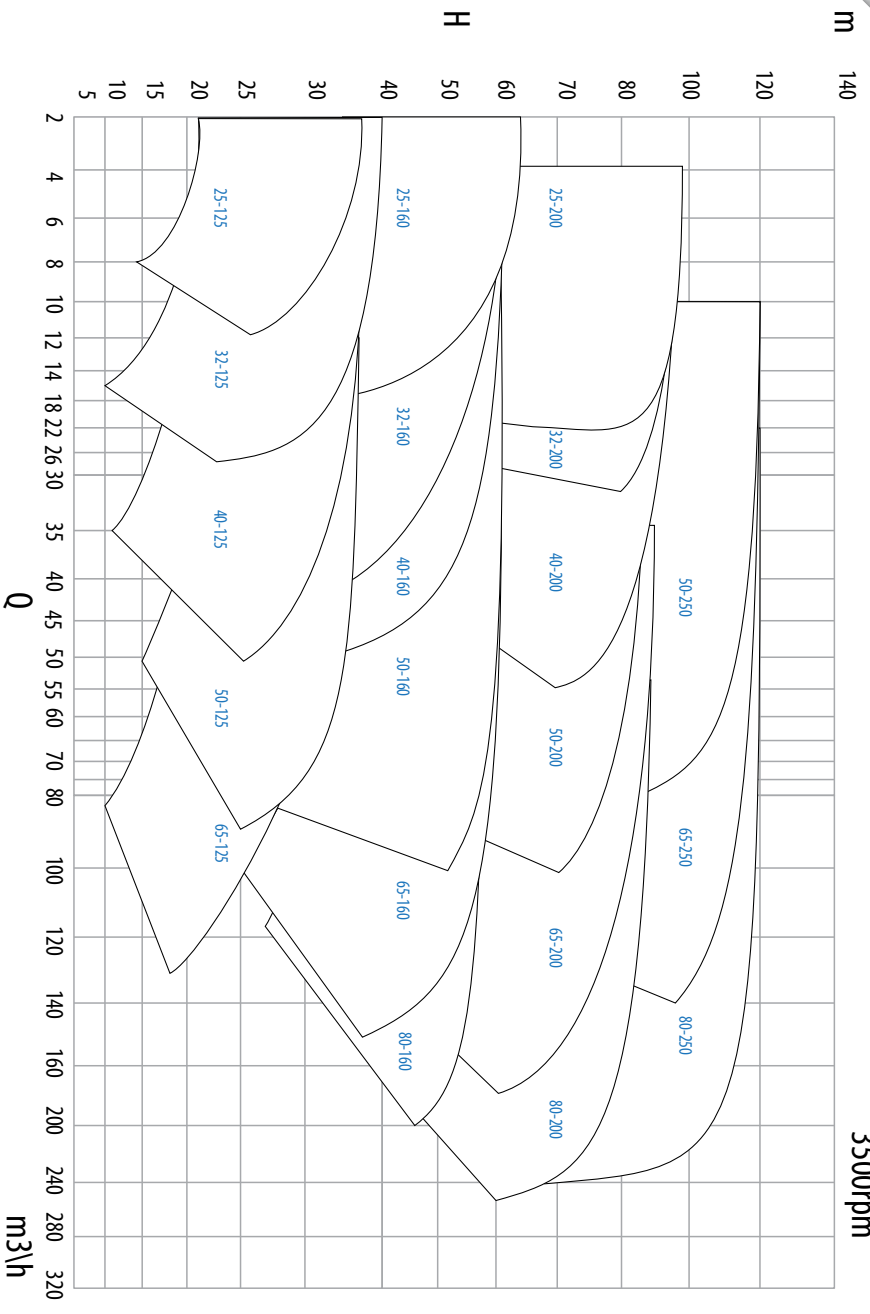

OVERALL DIMENSIONS

UTS Long Coupled - UTS-B Close Coupled

UTS

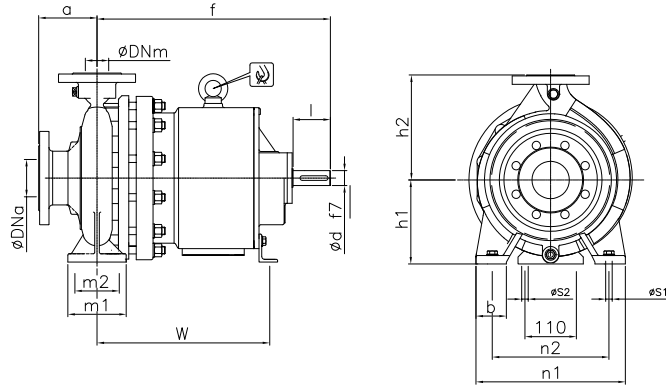

Pump Size	Pump Weight	DNa	DNm	a	h1	h2	f	d	l	b	m1	m2	n1	n2	S1	S2	W	
	Kg	∅	∅	mm	mm	mm	mm	∅ mm	mm	mm	mm	mm	mm	mm	∅ mm	mm		
UTS I° FRAME	40-25-125	50	40	25	80	112	140	385	24	50	50	100	70	190	140	M12	14	285
	40-25-160	55	40	25	80	132	160	385	24	50	50	100	70	240	190	M12	14	285
	40-25-200	85	40	25	80	160	180	385	24	50	50	100	70	240	190	M12	14	285
	50-32-125	50	50	32	80	112	140	385	24	50	50	100	70	190	140	M12	14	285
	50-32-160	55	50	32	80	132	160	385	24	50	50	100	70	240	190	M12	14	285
	50-32-200	90	50	32	80	160	180	385	24	50	50	100	70	240	190	M12	14	285
	65-40-125	50	65	40	80	112	140	385	24	50	50	100	70	210	160	M12	14	285
	65-40-160	55	65	40	80	132	160	385	24	50	50	100	70	240	190	M12	14	285
	65-40-200	90	65	40	100	160	180	385	24	50	50	100	70	265	212	M12	14	285
	80-50-125	55	80	50	100	132	160	385	24	50	50	100	70	240	190	M12	14	285
80-50-160	60	80	50	100	160	180	385	24	50	50	100	70	265	212	M12	14	285	
80-50-200	90	80	50	100	160	200	385	24	50	50	100	70	265	212	M12	14	285	
100-65-125	60	100	65	100	160	180	385	24	50	65	125	95	280	212	M12	14	285	
UTS II° FRAME	65-40-250	180	65	40	100	180	225	500	32	80	65	125	95	320	250	M12	14	370
	80-50-250	180	80	50	125	180	225	500	32	80	65	125	95	320	250	M12	14	370
	100-65-160*	80	100	65	100	160	200	500	32	122,5	65	125	95	280	212	M12	14	370
	100-65-200	160	100	65	100	180	225	500	32	80	65	125	95	320	250	M12	14	370
	100-65-250	180	100	65	125	200	250	500	32	80	80	160	120	360	280	M16	14	370
	125-80-160*	80	125	80	125	180	225	500	32	122,5	65	125	95	320	250	M12	14	370
	125-80-200	160	125	80	125	180	250	500	32	80	65	125	95	345	280	M12	14	370
	125-80-250	190	125	80	125	225	280	500	32	80	80	160	120	400	315	M16	14	370
	125-100-200	190	125	100	125	200	280	500	32	80	80	160	120	360	280	M16	14	370

*II° FRAME PUMP ARRANGED AS A I° FRAME

FLANGE
UNI EN 1092-1 PN 16RF
Upon request slotted to ANSI 150

UTS-B

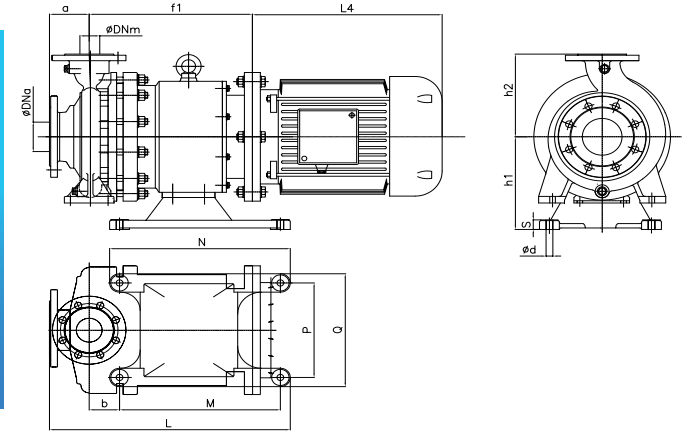

Pump model	DNa	DNm	a	b	h1	h2	L	M	N	P	Q	d	s										
	∅mm	∅mm	mm	mm	mm	mm	mm	mm	mm	mm	mm	mm	mm										
40-25-125	40	25	80	70	180	140	445 (730)*	275 (560)*	315 (600)*	200	240	17 (18)*	24 (13)*										
40-25-160						160																	
40-25-200						180																	
50-32-125	50	32				140																	
50-32-160						160																	
50-32-200						180																	
65-40-125	65	40	100	100	180	140	465 (750)*	275 (560)*	315 (600)*	200	240	17 (18)*	24 (13)*										
65-40-160						160																	
65-40-200						180																	
80-50-125	80	50				100								100	180	160	465 (750)*	275 (560)*	315 (600)*	200	240	17 (18)*	24 (13)*
80-50-160																180							
80-50-200																200							
100-65-125	100	65	100	65	125		95	280	212	M12	14	285											

(*) for motor size 160 - L4 according to manufacturing dimension

UTS-B I° FRAME	Motor Size				
	80-B14	90-B14	100/112-B5	132-B5	160-B5
	f1 (mm)				
All sizes	mm	mm	mm	mm	mm
	266	266	276	287	322

Pump model	DNa	DNm	a	b	h1	h2	L	M	N	P	Q	d	s
	∅mm	∅mm	mm	mm	mm	mm	mm	mm	mm	mm	mm	mm	mm
80-50-250	80	50	125	75	252	225	630	405	455	257	307	17	27
100-65-200	100	65	100				606						
100-65-250							630						
100-65-160**	100	65	100	78	200	225	472 (758)*	275 (560)*	315 (600)*	200	240	18	21 (13)*
125-80-160**	125	80	125				498 (783)*						

(*) for motor size 132 - 160 - L4 according to manufacturing dimension

** II° Frame executed as a I° Frame

UTS-B II° FRAME	Motor Size				
	80-B14	90-B14	100/112-B5	132-B5	160-B5
	f1 (mm)				
80-50-250	mm	mm	mm	mm	mm
100-65-200	344	344	354	385	410
100-65-250					
100-65-160**	275	275	285	300	330
125-80-160**					

OVERALL DIMENSIONS

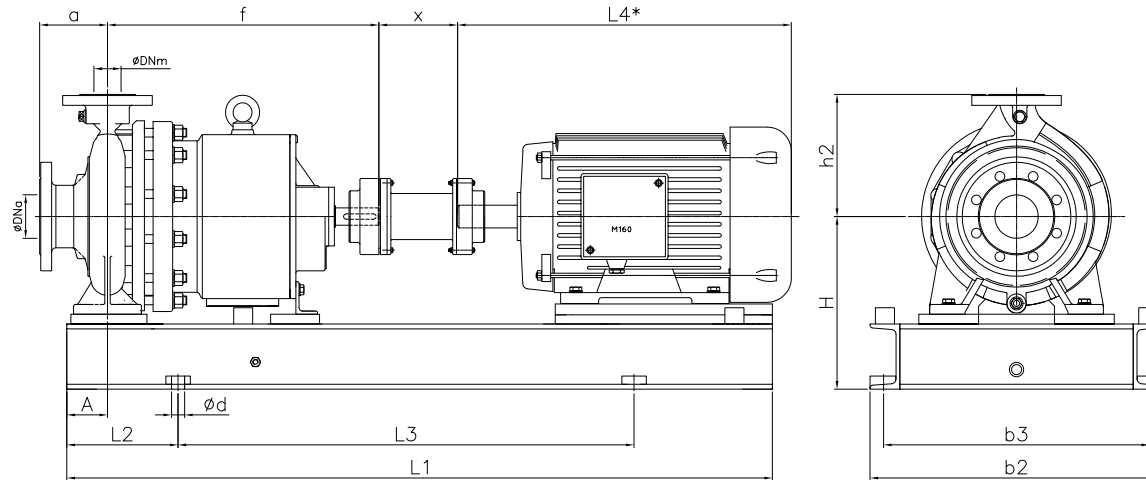

UTS I° FRAME								Motor Frame		
Pump model	Dna	DNm	A	a	f	x	h2	H		
	∅	∅	mm	mm	mm	mm	mm	mm	mm	mm
40-25-125	40	25	60	80	385	103	140	257	272	272
40-25-160	40	25	60	80	385	103	160	257	272	272
40-25-200	40	25	60	80	385	103	180	285	300	300
50-32-125	50	32	60	80	385	103	140	257	272	272
50-32-160	50	32	60	80	385	103	160	257	272	272
50-32-200	50	32	60	80	385	103	180	285	300	300
65-40-125	65	40	60	80	385	103	140	257	272	272
65-40-160	65	40	60	80	385	103	160	257	272	272
65-40-200	65	40	60	100	385	103	180	285	300	300
80-50-125	80	50	60	100	385	103	160	257	272	272
80-50-160	80	50	60	100	385	103	180	285	300	300
80-50-200	80	50	60	100	385	103	200	285	300	300
100-65-125	100	65	60	100	385	103	180	285	300	300

UTS I° FRAME	L1	L2	L3	b2	b3	d
Motor Frame	mm	mm	mm	mm	mm	∅ mm
90/100/112	900	150	600	390	350	19
132	1000	170	660	450	400	24
160-180	1120	190	740	490	440	24

*L4 according to manufacturing dimension

UTS II° FRAME								Motor Frame				
Pump model	Dna	DNm	A	a	f	x	h2	H				
	∅	∅	mm	mm	mm	mm	mm	mm	mm	mm	mm	mm
65-40-250	65	40	75	100	500	145	225	298	318	318	358	383
80-50-250	80	50	75	125	500	145	225	298	318	318	358	383
100-65-160	100	65	75	100	500	145	200	278	298	318	NA	NA
100-65-200	100	65	75	100	500	145	225	298	318	318	358	383
100-65-250	100	65	90	125	500	145	250	318	338	338	358	383
125-80-160	125	80	75	125	500	145	225	298	318	318	NA	NA
125-80-200	125	80	75	125	500	145	250	298	318	318	358	383
125-80-250	125	80	90	125	500	145	280	NA	363	363	383	383
125-100-200	125	100	90	125	500	145	280	318	338	338	358	383

UTS II° FRAME	L1	L2	L3	b2	b3	d
Motor Frame	mm	mm	mm	mm	mm	∅ mm
132	1120	190	740	490	440	24
160-180	1300	205	840	540	490	24
200-225	1400	230	940	610	550	28

*L4 according to manufacturing dimension



C.D.R. Pompe S.p.A.

Via P. Togliatti, 26/A - 20030 Senago (MI) - Italy

Tel. +39029901941

Fax +39029980606

www.cdrpompe.com

info@cdrpompe.it

TB - UTS_20134_01



For further info, please visit
www.cdrpompe.com

Technical Characteristics

The technical data and characteristics stated in this General Catalogue are not binding. CDR Pompe S.p.a. reserves the right to make modifications without notice. Therefore data, dimensions, performances and any other stated issues are indicative only and not binding. Anyway for any technical details you must require an up-to-date product technical card.