

AJ180G418R180PA

SOTR

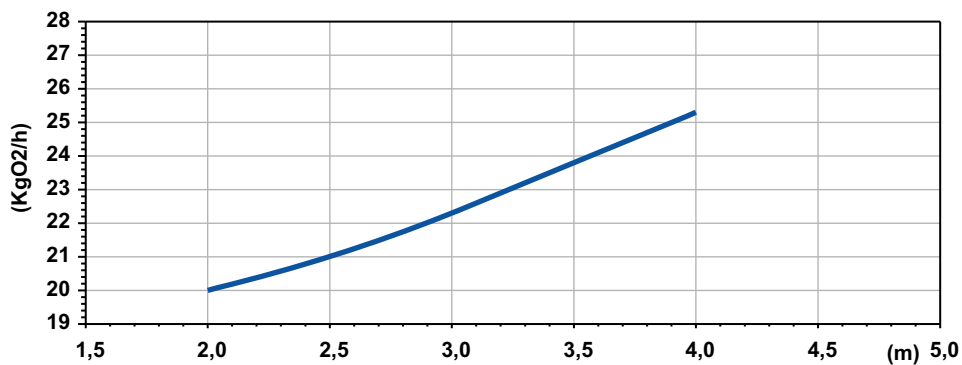

Potenza Assorbita - Absorbed Power P1
 Puissance Absorbée - Leistungsaufnahme P1
 Potencia Absorbida - Поглощенная мощность P1

Aria Aspirata - Suction Air
 L'air D'aspiration - Saugluft
 Succión De Aire - Аспирированный воздух
 Nm³ a 0 °C, RH 0 %, p = 101,3 kPa

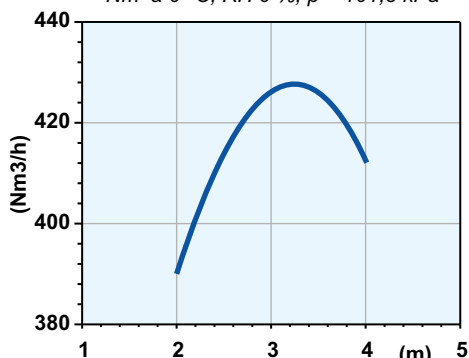
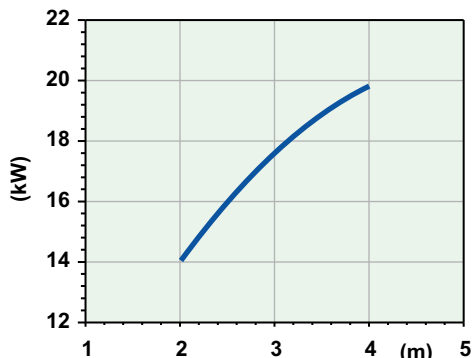

Battente idraulico - Hydraulic head - Charge hydraulique - Hydraulischen Belastung
 Cabezal hidráulico - Гидронапор

Code	5009656
Type	AJ180G418R180PA
Suction (mm)	DN100
Free passage (mm)	30x46
Immersion depth (m)	2-4
Motor type	M418T-20-400/50YY-IE3
Power supply	3ph 400/690V-50Hz
MOTOR Rotation speed R.P.M.	1441
Rated power P2 (kW)	20
Rated current I (A)	37,4
Starting current Is (A)	221
Weight (Kg)	430
Cable	H07RN/F 10G4
SOTR OBTAINED FOLLOWING STANDARD UNI EN 12255-15:2004	

Dimensioni - Dimensions - Dimensions - Abmessungen - Dimensiones - Габариты (mm)

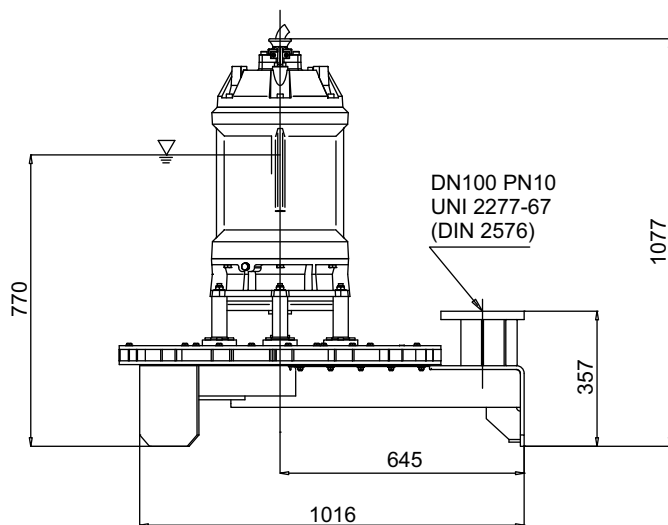
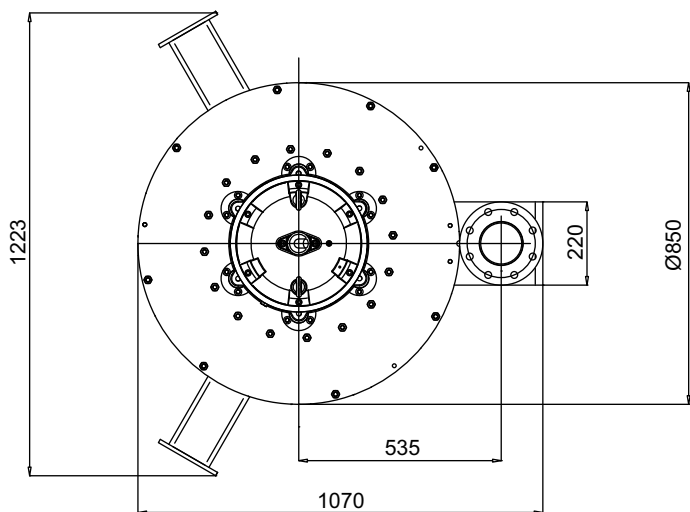

LIVELLO MINIMO DI SOMMERGIBILITÀ - MINIMUM SUBMERSIBLE LEVEL - NIVEAU MINIMUM D'IMMERSION
 MINDESTWASSERSTAND - NIVEL SUMERGIBLE MÍNIMO - МИНИМАЛЬНАЯ ГЛУБИНА ПОГРУЖЕНИЯ