

# JUNG PUMPEN COMPLI 400 SEWAGE LIFTING STATIONS



## APPLICATION

This sewage lifting station for detached houses is fitted for versatile fields of application. During the design work, special attention was given to easy handling (recessed grips), space-saving erection and uncomplicated installation.

The submersible unit is permitted for general use in areas subject to flooding. The control unit has to be fitted in a well ventilated flood-proof room.

The PE tank has freely accessible drains, a top-mounted cleaning opening and a height-adjustable clamp-type inlet flange which can be adjusted on site to an inlet height of between 180 and 250 mm depending on the drainage situation.

Other horizontally and vertically arranged additional inlets increase the connection and drainage options. The vortex impeller of the pump offers the safety you can rely on.



compli 400

- Ready-to-connect
- Submersible
- Vertical / horizontal additional inlets
- Revolver clamping flange
- PE tank
- Vortex impeller

## PERFORMANCE

compli 400

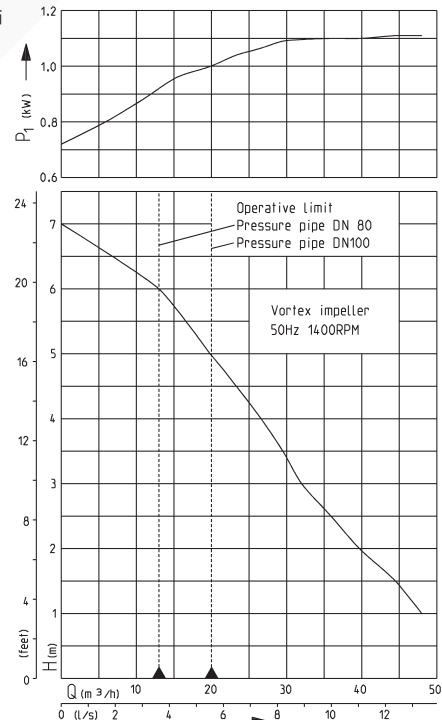

42541-02

We reserve the right to change specifications without notice

Pump performance is subject to ISO 9906 tolerances

The minimum flow velocity in the pressure piping must be 0.7 m/s according to EN 12056.  
This data is represented in the performance curve as a limit of application.

# JUNG PUMPEN COMPLI 400

## SEWAGE LIFTING STATIONS

### SEWAGE LIFTING STATIONS

compli type	Tank capacity l	Inlet height mm	Free passage mm	Clamp-type inlet flange	Ventilation	Weight approx.	Code No.
400	ca. 64	180/250	70	DN 100	DN 70	55 kg	<b>JP00637</b>
400 E (alternating current)	ca. 64	180/250	70	DN 100	DN 70	56 kg	<b>JP09770</b>
400 with non-return valve mounted	ca. 64	180/250	70	DN 100	DN 70	70 kg	<b>JP09322</b>
400 E (alternating current) with non-return valve mounted	ca. 64	180/250	70	DN 100	DN 70	71 kg	<b>JP09324</b>

**Caution** : compli 400 S type are not available due to revolver clamping flange

### PERFORMANCE

compli type	Delivery head H [m]	1	2	3	4	5	6
400	Delivery rate Q [m <sup>3</sup> /h]	48	40	33	27	20	13

### ELECTRICAL DATA

compli type	Type of current	Voltage Volt	Motor rating kW		RPM min. <sup>-1</sup>	Current Ampere	Cable (4 m) Tank control	Cable (1.5 m) Control plug	Plug
			P <sub>1</sub>	P <sub>2</sub>					
400	3-phase	3/N/PE~400	1.25	0.87	1390	2.2	H07RN-F-6G1.5	H05VV-F-5G1.5	CEE-
400 E	1-phase	1/N/PE~230	1.55	1.10	1428	7.1	H07RN-F-4G1.5	H05VV-F-3G1.5	Safety-

#### Mounting arrangement

Direct connection in a next-door room to save space.  
Additional drains are connected to the additional inlet.

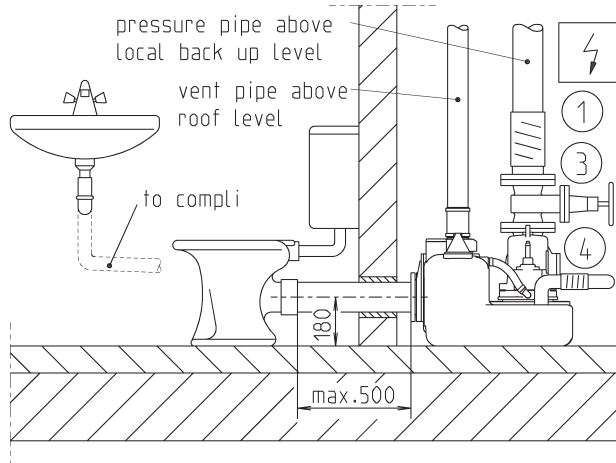

29748-01

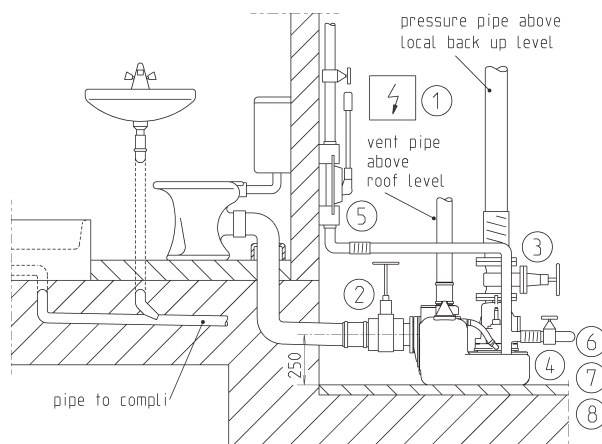

29749-01





All types have DN 80 / PN 10 connecting flange, however with pipe socket DN 100. For this reason, non-return valves and shut-off valves need to be chosen for DN 80 only in case of direct erection. The downstream pressure pipe is connected to DN 100 by an elastic connection.

In keeping with the construction and testing principles of German / European standard DIN EN 12050, sewage lifting stations are to be used for the transport of faecal matter and domestic waste-water in building drainage systems as described in German standard DIN 1986 T3. In keeping with the stipulations of German / European standard DIN EN 12056-4 they have to be mounted with collecting tanks inside building permitting a free space of 60 cm for operation and repair. The pressure pipe has to be passed above the locally defined backpressure level and a non-return valve tested in keeping with German / European standard 12050-4 has to be mounted. In keeping with German / European standard 12056 the ventilation pipe has to be passed up to the roof.

# JUNG PUMPEN COMPLI 400

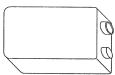
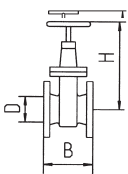
## SEWAGE LIFTING STATIONS

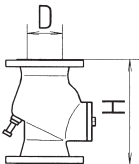
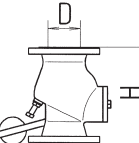
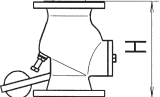
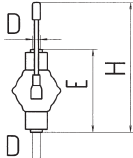
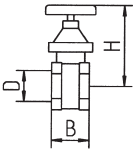
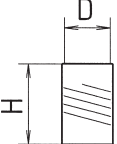
### ACCESSORIES

		Code No.
	<b>1 Rechargeable battery</b> for control for mains-independent alarm	<b>JP44850</b>
	<b>2 PVC sluice valve</b> (with two pipe sockets) for 4" inlet (DN 100) PN 1	$\frac{H}{360} \quad \frac{B}{295} \quad \frac{E}{60} \quad \frac{F}{81} \quad \frac{D}{110}$ <b>JP28297</b>
	<b>3 Sluice valve*</b> for 3" pressure side (DN 80), PN 10, DIN EN 1171	$\frac{H}{315} \quad \frac{B}{180} \quad \frac{D}{DN 80}$ for 3" pressure side <b>JP00639</b>
	<b>4 Swing-type check valve * R 80,</b> PN 4, flange PN 10, DIN 3202, DIN EN 12050-4 without counterweight	<b>JP00706</b>
	<b>Swing-type check valve * R 80 G,</b> PN 4, flange PN 10, DIN 3202, DIN EN 12050-4 with adjustable counterweight	$\frac{H}{260} \quad \frac{D}{80} \quad \frac{DN}{DN}$ <b>JP00707</b>
	<b>Ball-type check valve * K 80,</b> PN 4, flange PN 10, DIN 3202, DIN EN 12050-4	<b>JP44781</b>
	<b>5 Hand diaphragm pump</b> for emergency purposes (up to $H_{geod}$ 15 m)	$\frac{H}{ca. 640} \quad \frac{E}{430} \quad \frac{D}{1\frac{1}{2}''}$ <b>JP00255</b>
	<b>6 Stop valve, 1½" (DN 40), PN 16</b>	$\frac{H}{125} \quad \frac{B}{max. 60} \quad \frac{D}{1\frac{1}{2}''}$ <b>JP44786</b>
	<b>7 Elastic connection 1½" (DN 40), PN 4</b>	$\frac{H}{120} \quad \frac{D}{50}$ <b>JP44777</b>
	<b>8 Clamp 1½"</b>	<b>JP44763</b>

\* with screws and seal

# JUNG PUMPEN COMPLI 400

## SEWAGE LIFTING STATIONS

### TECHNICAL DATA

#### Pump

Vertical, single-stage, submersible, vortex impeller, spiral casing with vertical DN 100 outlet, flanged to PE tank with cleaning opening.

#### Bearing

Common shaft for pump and motor, grease-packed ball bearing.

#### Seal

Double radial shaft sealing ring.

#### Motor

Submersible, IP 68 type of protection, insulation class F, winding thermostats for the protection of the drives against overheating, automatic start-up by float switch and control, mains connection by 16 A plug, S 3 type of operation in keeping with German standard VDE.

#### Materials

Tank made of corrosion resistant and environmentally compatible polyethylene; pump and motor housing made of wear-resistant grey cast iron, single-vane impeller made of wear-resistant glass-fibre reinforced plastic; shaft made of stainless steel; rubber inlet hose.

#### Scope of supply

Ready-to-connect tank system in keeping with German / European standard 12050 with height-adjustable DN 100 clamp-type flange for inlet heights 180 / 250 mm, horizontal and vertical additional inlets diam. 50 mm, DN 100 inlet option from the top, mounted submersible pump and DN 80 connection flange with pipe unit diam. 110, optionally with pre-mounted DN 80 non-return valve, one elastic connection each with clamps for plastic pressure pipes and a sleeved pipe for DN 70 ventilation pipe, automatic level control, control unit (IP 44 type of protection) with motor protection, contactors, transformer, mains-independent, optionally acknowledgeable alarm system and potential-free make contact for collective failure messages, optical display of sense of rotation (three-phase current), alarm and operation, test run button. To be fitted with a micro-processor control as well upon request.

Cable between tank and control 4 m,  
Cable between control and plug 1.5 m.  
Accessories to be ordered according to mounting drawing.

Specifications of German / European standard DIN EN 12056-4, paragraphs 5.1 and 5.2

- Working area of 60 cm above and around all parts of disposal unit that have to be operated.
- Pump sump for the drainage of the operation room
- Swing-type check valve on the pressure side
- Stop valve on the pressure side
- Stop valve on the inlet side
- Disposal units have to be mounted buoyancy-proof



### Dimensions with swing-type check valve (mm)

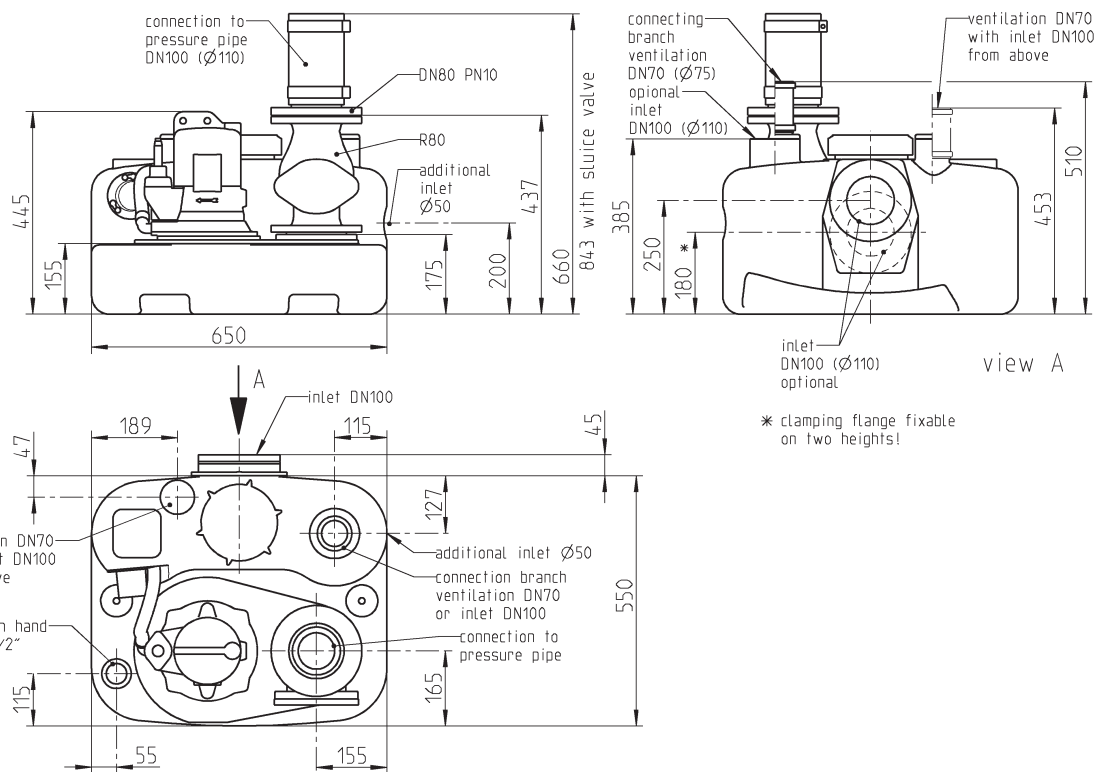

42922-00