

## AJ75G413R95MA

### SOTR

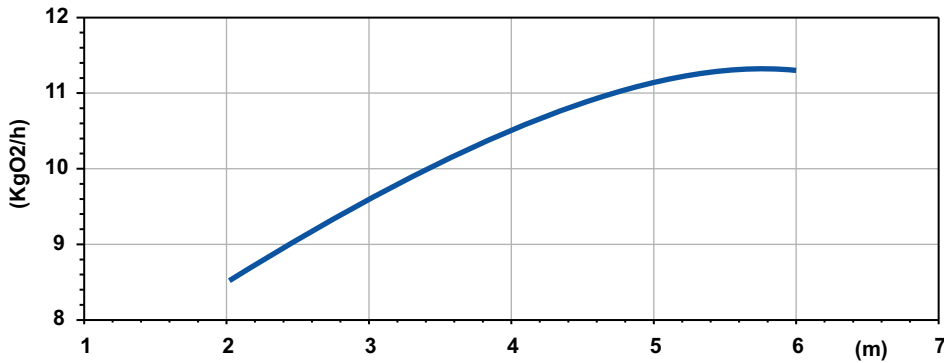

Potenza Assorbita - Absorbed Power P1  
 Puissance Absorbée - Leistungsaufnahme P1  
 Potencia Absorbida - Поглощенная мощность P1

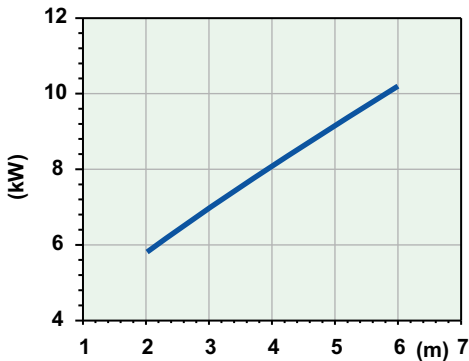

Aria Aspirata - Suction Air  
 L'air D'aspiration - Saugluft  
 Succión De Aire - Аспирированный воздух  
 $Nm^3$  a 0 °C, RH 0 %, p = 101,3 kPa

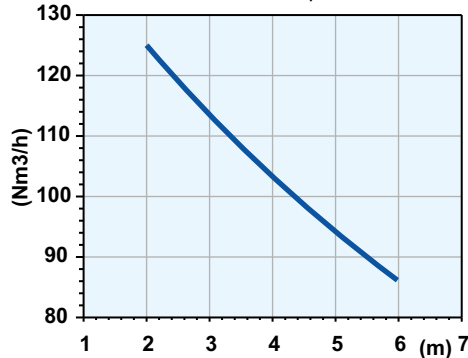

Battente idraulico - Hydraulic head - Charge hydraulique - Hydraulischen Belastung  
 Cabezal hidráulico - Гидронапор

Code	5009654
Type	<b>AJ75G413R95MA</b>
Suction (mm)	DN80
Free passage (mm)	30x35
Immersion depth (m)	2-6
Motor type	M413T-10-400/50YY-IE3
Power supply	3ph 400/690V-50Hz
MOTOR Rotation speed R.P.M.	1436
Rated power P2 (kW)	10
Rated current I (A)	19
Starting current Is (A)	112
Weight (Kg)	250
Cable	H07RN/F 12G2.5

SOTR OBTAINED FOLLOWING  
 STANDARD UNI EN 12255-15:2004

### Dimensioni - Dimensions - Dimensions - Abmessungen - Dimensiones - Габариты (mm)

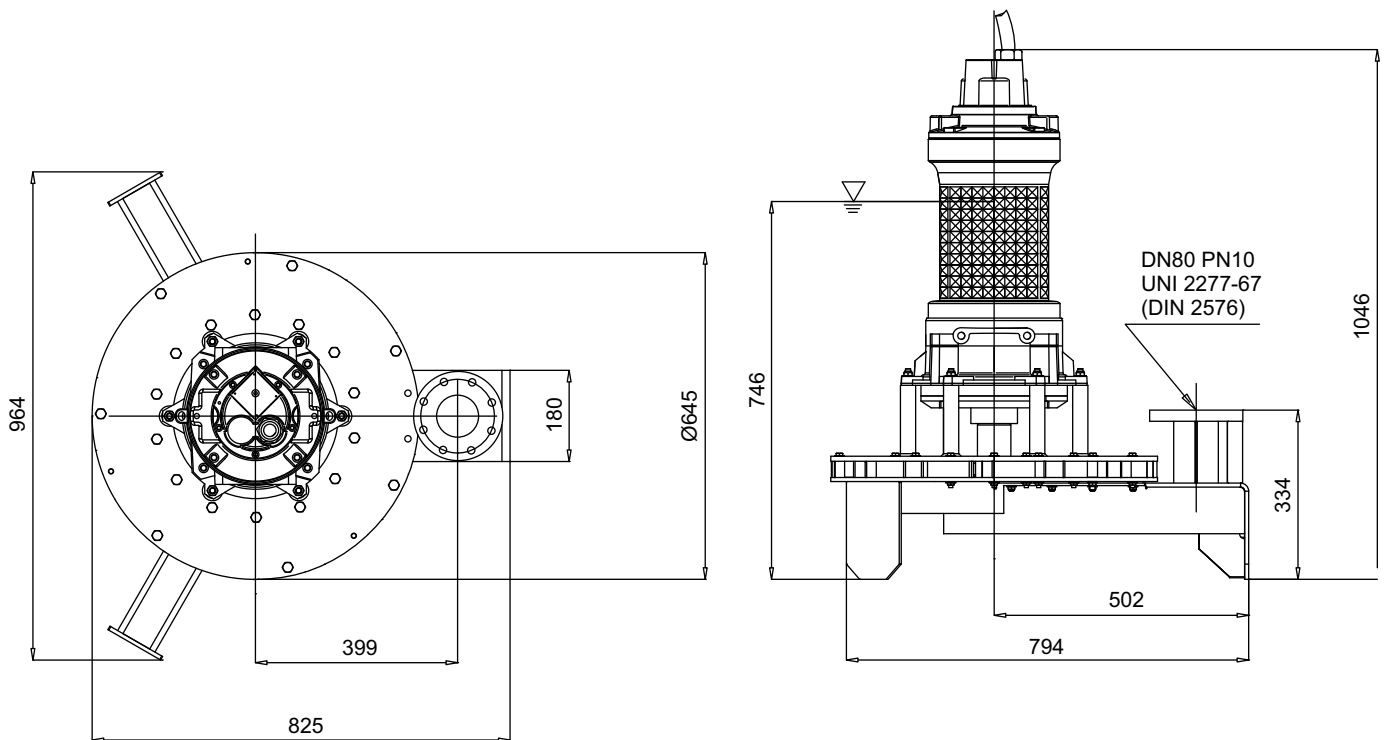

LIVELLO MINIMO DI SOMMERGIBILITÀ - MINIMUM SUBMERSIBLE LEVEL - NIVEAU MINIMUM D'IMMERSION  
 MINDESTWASSERSTAND - NIVEL SUMERGIBLE MÍNIMO - МИНИМАЛЬНАЯ ГЛУБИНА ПОГРУЖЕНИЯ